

SAFETY ON THIS JOB
DEPENDS ON YOU

**VIRGINIA KEY
DADE COUNTY, FLORIDA**

**PLANS
FOR**

**SHORELINE STABILIZATION
PROJECT**



DEPARTMENT OF THE ARMY
JACKSONVILLE DISTRICT, CORPS OF ENGINEERS
JACKSONVILLE, FLORIDA

TO ACCOMPANY SOLICITATION
NO. DACW17-02-R-0023

2002

 INCREASE PROFIT - SUBMIT VECP'S

D. O. FILE NO. 24-38,277

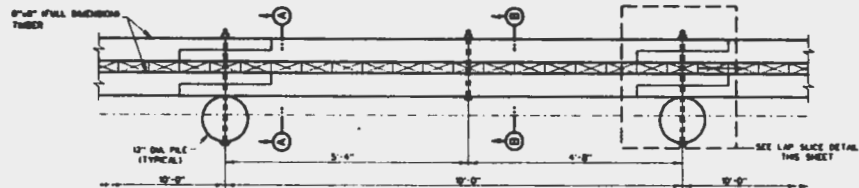

PARTIAL PLAN
SCALE "X"

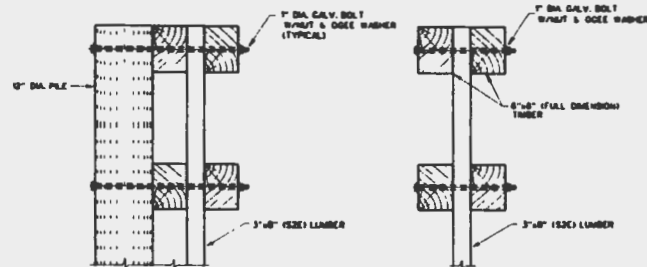

SECTION A-A
SCALE "Y"

SECTION B-B
SCALE "Y"

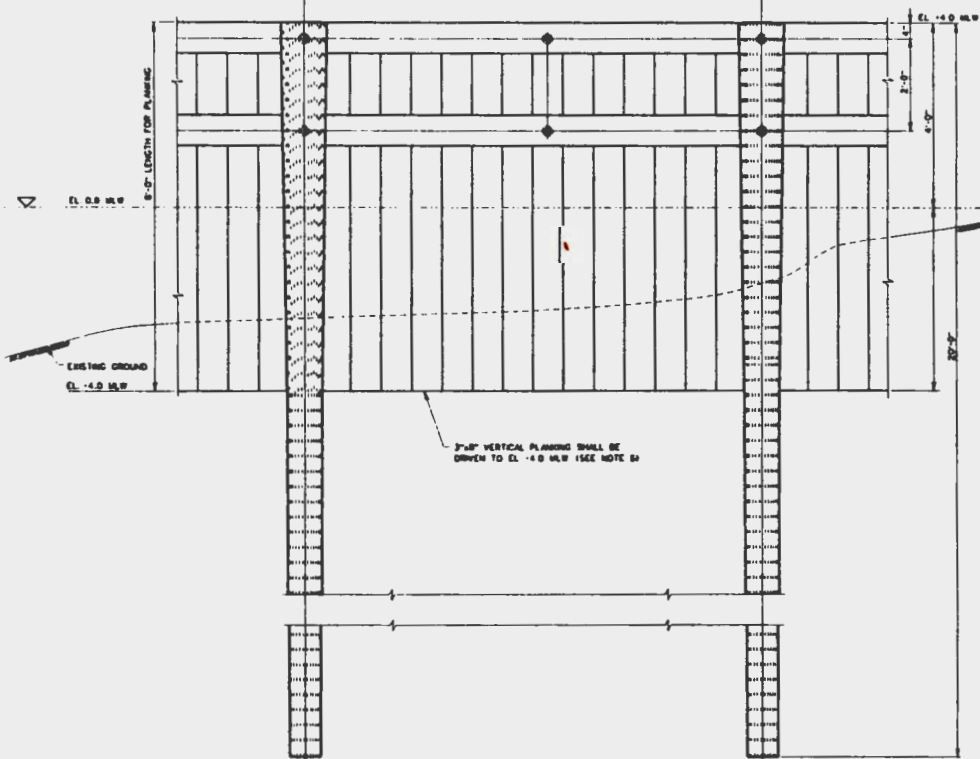

PARTIAL ELEVATION
SCALE "Z"

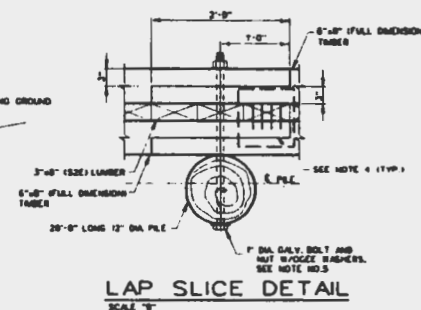

LAP SLICE DETAIL
SCALE "Y"

NOTES:

1. ALL TIMBER, LUMBER AND PILES SHALL BE DUAL TREATED.
2. ALL BOLTS, NUTS, WASHERS, SCREWS, AND NAILS SHALL BE GALVANIZED.
3. PILE DIAMETER SHALL BE A MINIMUM BUTT DIAMETER MEASURED 3' FROM THE BUTT END.
4. USE FOUR 304 GALV. NAILS LAGBOLAR OR RING SHANKS TO FASTEN VERTICAL PLANKS THAT ARE NOT BOLTED TO TIMBER. PREDRILL PILE HOLES (1/8" LESS THAN NAIL DIAMETER) TO PREVENT SPLITTING. OPTION TO USE THREE 6" LENGTH NO. 12 STEEL SQUARE DRIVE PRODUCTION SCREWS.
5. SEAL-TITE WASHER HEAD TIMBER BOLT WITH SEAL-TITE WASHER NUT MAY BE USED INSTEAD OF STD BOLT W/OOGE WASHER AND NUT.
6. PLANKING FOR WALL SHALL BE CONSTRUCTED ON EAST SIDE OF PILES FOR ALL TIMBER CRONS.

GRAPHIC SCALES

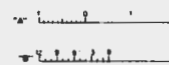

US Army Corps of Engineers
 Savannah District
 SHEET NO. 24-38.277
 DATE: 02/24/03

NO.	DATE	BY	CHKD.	APP'D.
1				
2				
3				
4				
5				
6				

DEPT. HEAD OF THE DISTRICT
 DISTRICT ENGINEER

NO. 24-38.277
 SHEET NO. 24-38.277

MISSISSIPPI RIVER
 SAVANNAH DISTRICT
 SHORELINE STABILIZATION
 PROJECT
 TIMBER CRONS
 CRON DETAILS

DRAWING NO.
 3/1

A B C D E F G H

EXISTING TIMBER GROIN FIELD DATA

TIMBER GROIN NO.	TOTAL VISIBLE LENGTH OF GROIN (FT.)	LENGTH OF TIMBER SECTIONS (FT.)	LENGTH OF WINGPILE SECTIONS (FT.)	MAX. DISTANCE INTO SEAGRASS (FT.)	LENGTH OF DAMAGED TIMBER SECTIONS (FT.)	LENGTH OF WINGPILE TO BE REMOVED (FT.)	NUMBER OF WINGPILE TO BE REMOVED (FT.)	LENGTH OF SEAGRASS END OF TIMBER GROIN TO BE SHORTENED (FT.)	ADDITIONAL LENGTH ADDED TO LANDWARD END	LENGTH OF TIMBER GROIN TO BE REBUILT (FT.)
TG1	80	80	0	20	40	0	0	20	20	80
TG2	90	50	0	0	30	0	0	0	20	70
TG3	50	50	0	0	30	0	0	0	20	70
TG4 #	50	50	0	0	40	0	0	0	10	60
TG5 #	50	50	0	0	10	0	0	0	10	60
TG6 #	62	50	12	5	20	12	2	0	0	50
TG7 #	74	90	24	5	20	24	3	0	0	50
TG8	50	50	0	10	40	0	0	10	20	60
TG9 #	72	60	12	25	40	12	2	25	20	60
TG10 #	80	80	0	30	40	0	0	30	20	70
TG11 #	72	60	12	30	40	12	2	10	20	70
TG12 #	62	50	12	15	30	12	2	10	20	60
TG13 #	54	30	24	15	10	24	3	0	20	50
TG14	44	20	24	5	0	24	3	100	10	40
TG15 #	54	30	24	0	0	24	3	100	0	40
TG16 #	44	20	24	0	0	24	3	100	0	30
TG17 #	44	20	24	0	0	24	3	100	0	30
TG18 #	40	40	0	0	10	0	0	0	0	40
TG19 #	30	30	0	0	10	0	0	0	0	30
TG20	30	30	0	0	10	0	0	0	0	30
TG21	30	30	0	0	10	0	0	0	0	30
TG22	30	30	0	0	10	0	0	0	0	30
TG23	30	30	0	0	10	0	0	0	0	30
TG24	40	40	0	0	20	0	0	0	0	40
TG25	30	30	0	0	10	0	0	0	0	30
TOTALS	1222	1038	162		500	162	20	100	220	1100

TIMBER GROIN NO.	LENGTH OF GROIN (FT.)	ALIGNMENT	BEGINNING POINT
TGA	80	NORMAL TO BASELINE	BEHIND VEGETATION LINE
TGB	100	NORMAL TO BASELINE	BEHIND VEGETATION LINE
TGC	110	NORMAL TO BASELINE	BEHIND VEGETATION LINE
TOTAL	290		

NOTE:
 1. ALL 3 NEW TIMBER GROINS ARE NORMAL TO SHORELINE.
 2. VEGETATION LINE GENERALLY RUNS ALONG THE SCARP LINE EACH GROIN ANCHORS INTO THE SCARP BY VARYING AMOUNTS TO PREVENT FLIPPING.

- NOTE:
- # DENOTES THAT THE LANDWARD END OF GROIN IS BURNED, AND ADDITIONAL 10 FT. TIMBER SECTIONS MAY EXIST FURTHER LANDWARD.
 - (#) INDICATES GROINS WHERE TIMBER SECTIONS WILL BE EXTENDED INTO REGIONS WHERE CONCRETE WINGPILE WERE FORMERLY LOCATED.
 - THE MOST SEAWARD PILE OF AN EXISTING GROIN SHOULD SERVE AS A REFERENCE FOR PLACEMENT OF A NEW GROIN.
 - NEW GROINS SHOULD BE ALIGNED PARALLEL TO THE CORRESPONDING EXISTING GROIN.



ASCE
 AMERICAN SOCIETY OF CIVIL ENGINEERS
 1801 Alexander Bell Drive
 Reston, VA 20191-4400
 (703) 295-6000
 FAX (703) 295-6001
 WWW.ASCE.ORG

DEPARTMENT OF THE ARMY
 ENGINEERING DISTRICT, WEST OF MEMPHIS
 PROFESSIONAL ENGINEER

PROJECT NO. 24-38,277
 SHEET NO. 3/2

PROJECT TITLE
 SHORELINE STABILIZATION
 PROJECT
 TIMBER GROIN
 GROIN DATA

DRAWING NO.
 3/2

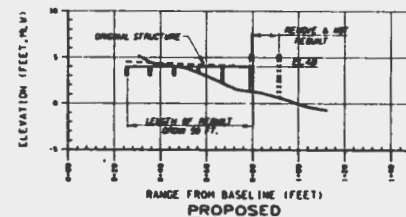
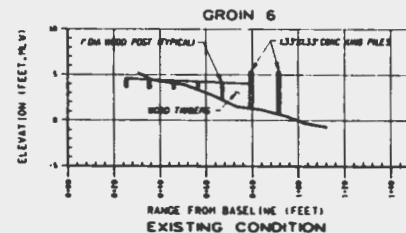
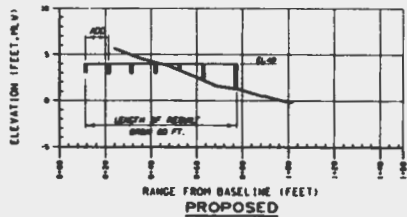
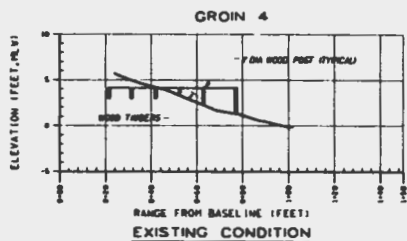
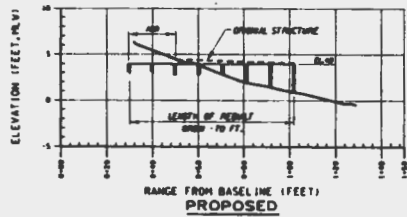
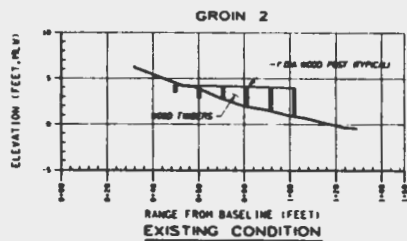
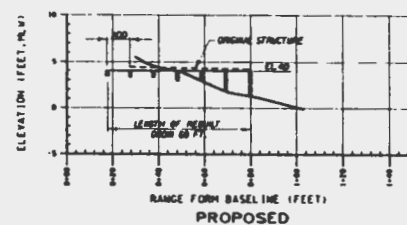
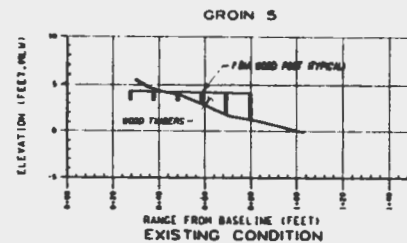
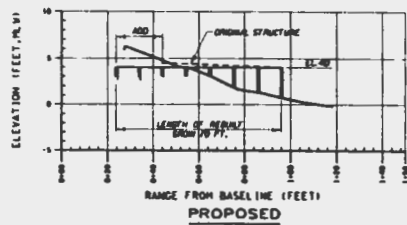
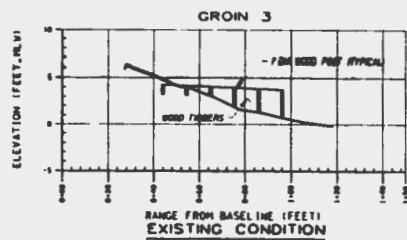
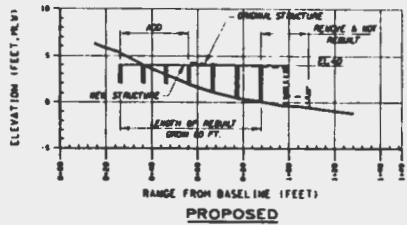
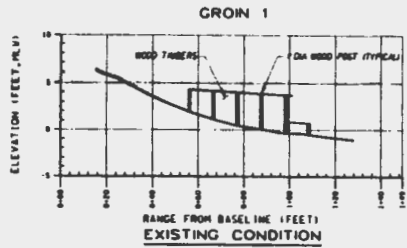

GRAPHIC SCALES

SCALE "A" (HORIZ.) 1" = 20'

SCALE "B" (VERT.) 1" = 10'

US Army Corps of Engineers
Alabama District
MOBILE DISTRICT OFFICE

DEPARTMENT OF THE ARMY
 ENGINEERING CENTER
 MOBILE, ALABAMA

DESIGNED BY: []
 DRAWN BY: []
 CHECKED BY: []
 IN CHARGE: []

DATE: []
 PROJECT NO.: []
 DRAWING NO.: 2-1-38-277

MOBILE DISTRICT OFFICE
 13701531 DMS AND FILES

**SHORELINE STABILIZATION
 PROTECTION
 TOWER GROIN
 EXISTING AND PROPOSED PROFILES
 GROIN NO. 1 THRU 6**

DRAWING NO.
3/4

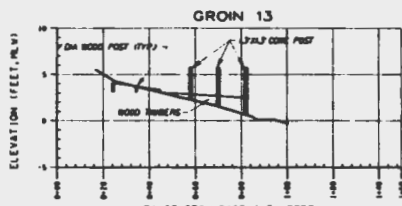

RANGE FROM BASELINE (FEET)
EXISTING CONDITION

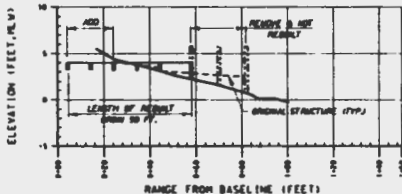

RANGE FROM BASELINE (FEET)
PROPOSED

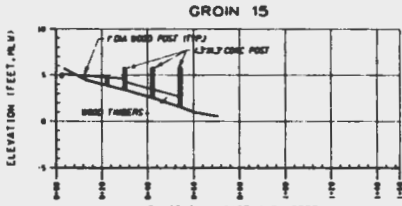

RANGE FROM BASELINE (FEET)
EXISTING CONDITION

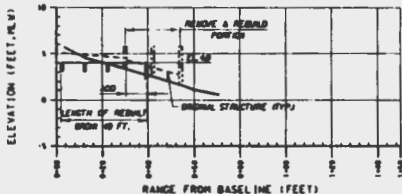

RANGE FROM BASELINE (FEET)
PROPOSED

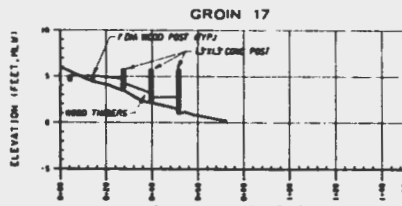

RANGE FROM BASELINE (FEET)
EXISTING CONDITION

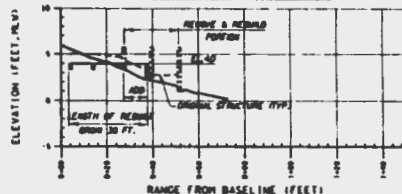

RANGE FROM BASELINE (FEET)
PROPOSED

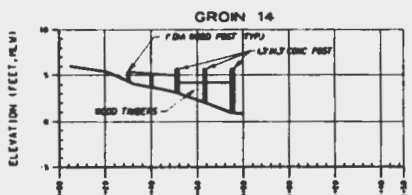

RANGE FROM BASELINE (FEET)
EXISTING CONDITION

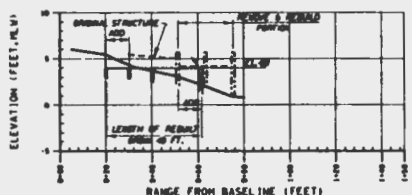

RANGE FROM BASELINE (FEET)
PROPOSED

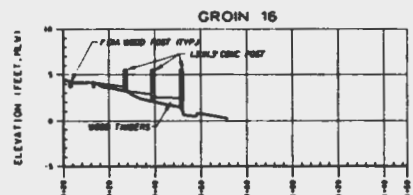

RANGE FROM BASELINE (FEET)
EXISTING CONDITION

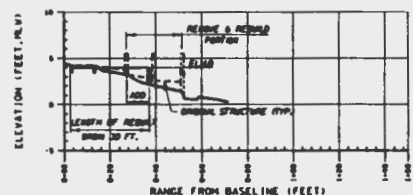

RANGE FROM BASELINE (FEET)
PROPOSED

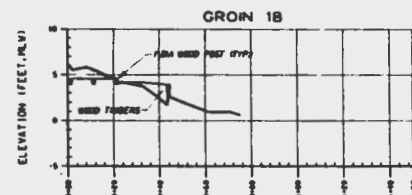

RANGE FROM BASELINE (FEET)
EXISTING CONDITION

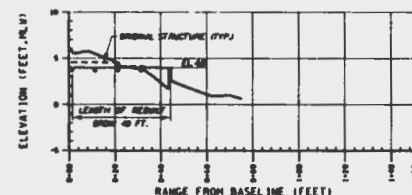

RANGE FROM BASELINE (FEET)
PROPOSED



US Army Corps of Engineers
Atlantic District

SAFETY BY THIS AND REVISIONS ONLY

NO.	DATE	BY	CHKD.	DESCRIPTION

DESIGNER OF THIS WORK
REGISTERED PROFESSIONAL ENGINEER
STATE OF FLORIDA

DATE	BY	CHKD.	DESCRIPTION

VELOCIA REE
DADE COUNTY, FLORIDA
SHORELINE STABILIZATION
PROJECT
TRACER CROSS
EXISTING AND PROPOSED PROFILES
DRAWING NO. 13 THRU NO. 18

DRAWING NO.
3/6

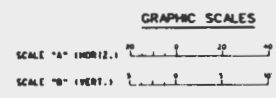

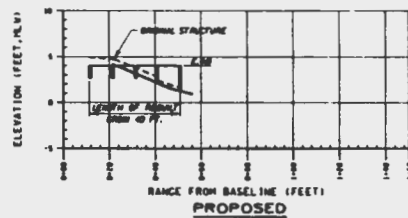
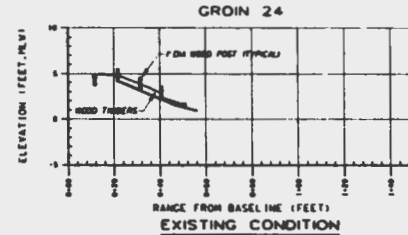
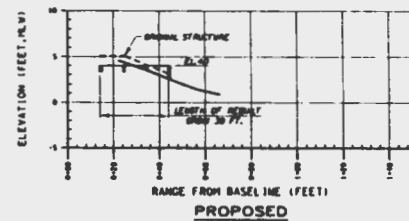
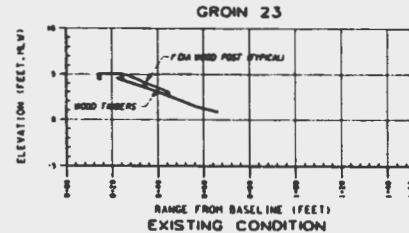
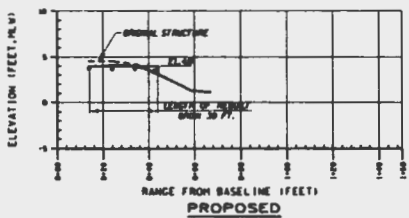
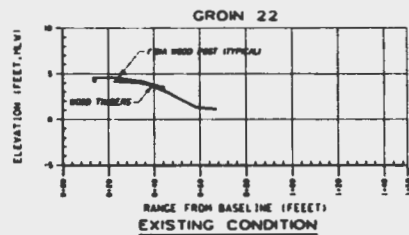
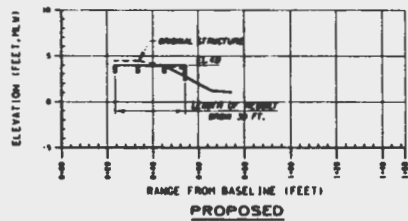
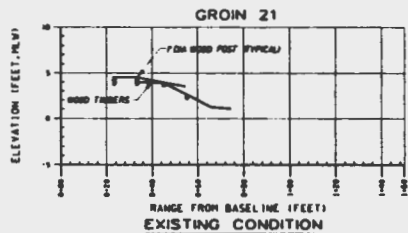
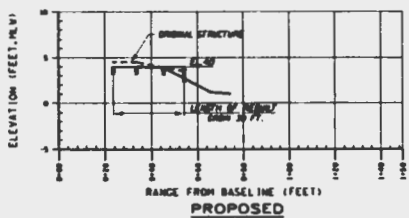
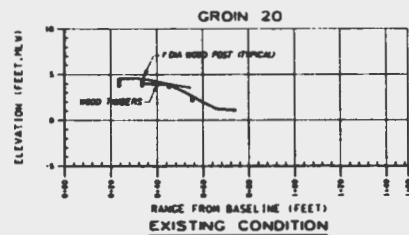
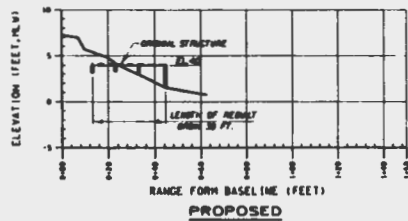
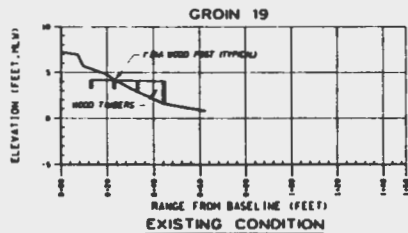

GRAPHIC SCALES

SCALE "A" (HORIZ.) 1" = 20'

SCALE "B" (VERT.) 1" = 10'

 US Army Corps of Engineers
 Hydrologic Branch
 SAFETY OF LIFE AND PROPERTY
 DEPARTMENT OF THE ARMY
 WASHINGTON, D.C. 20315-5000
 PROJECT NO. 19-100-0000-0000
 DRAWING NO. 19-100-0000-0000
 SHEET NO. 19-100-0000-0000
 DATE: 03/24/2003 03:31:23 PM
 PROJECT: SHORELINE STABILIZATION PROJECT
 DRAWING: EXISTING AND PROPOSED PROFILES
 GROIN NO. 19 THROUGH 24
 DRAWING NO. 3/7

CROSS SECTIONS PROPOSED GROW AREA

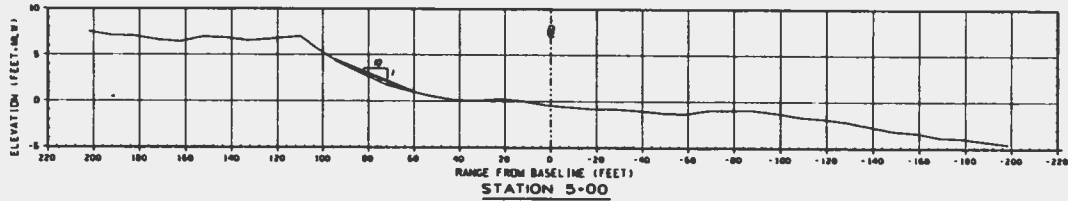
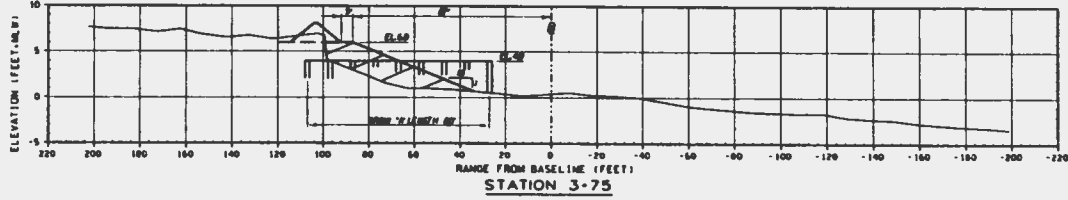
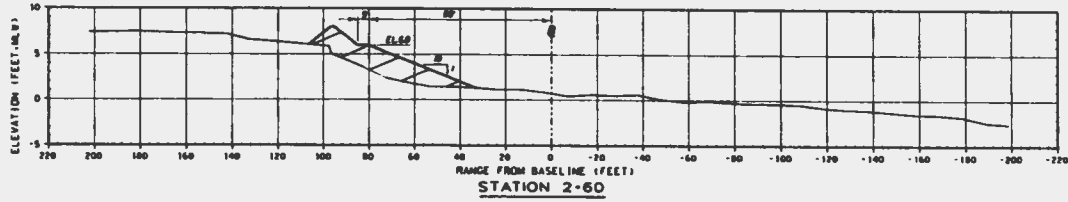
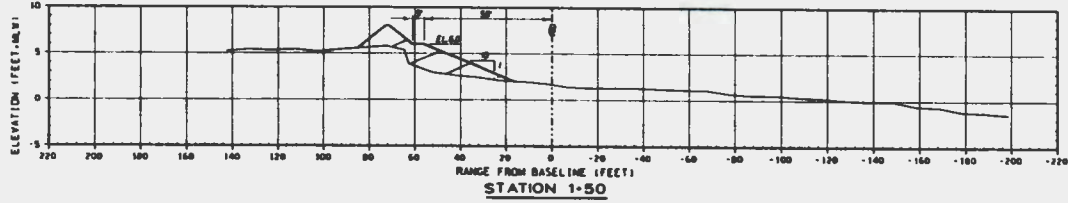
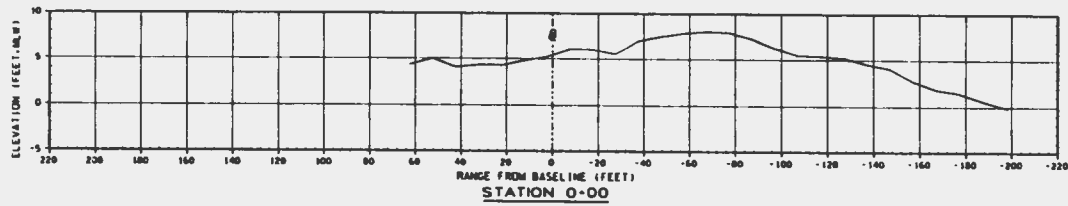

GRAPHIC SCALES

SCALE "A" (HORIZ.) 1" = 20'

SCALE "B" (VERT.) 1" = 5'

NOTES:
 1. REFER TO SHEET NO. 01 FOR
 2. REFER TO SHEET NO. 1 FOR NOTES.



LEG. Army Corps
 of Engineers
 Jacksonville District

DATE: 03/26/2003
 TIME: 01:33:38 PM

NO.	DATE	BY	DESCRIPTION

DEPARTMENT OF THE ARMY
 ENGINEERING DISTRICT OF JACKSONVILLE, FLORIDA

PROJECT NO. 24-30.277

PROJECT TITLE

SHORELINE STABILIZATION
 PROJECT
 BEACH PROFILES WITH SAND BARRIERS
 STA. 0+00 THROUGH STA. 5+00

DRAWING NO.
 4/2

PCL XL error

Subsystem: GE

Error: InternalOverflow or InsufficientMemory

Operator: LineRelPath

Position: 1260631

