

**TECHNICAL PUBLICATION
WRE #372**

February, 1999

**Hydrogeologic Characterization and
Estimation of Ground Water Seepage in the
Everglades Nutrient Removal Project**

By

Kevin P. Rohrer, P.G.

**Resource Assessment Division
Water Resources Evaluation Department
South Florida Water Management District
West Palm Beach, Florida 33406**

EXECUTIVE SUMMARY

This report summarizes the information obtained during the design, construction and operation of a ground water monitoring well network. This report also describes the hydrogeology of the Everglades Nutrient Removal (ENR) project and estimates the component of seepage underneath the L-7 levee that flows through culverts. Twenty-five monitoring wells were installed along the L-7 and perimeter levees to gather information of the local hydrogeology and to measure ground water levels and water quality. Wells were completed to elevations ranging from -77 to 5.5 feet National Geodetic Vertical Datum (NGVD).

The Surficial Aquifer System underlying the ENR is approximately 200 feet thick and can be subdivided into four (4) distinct units. A four to five foot layer of organic peat covers the entire ENR project site. The underlying sand is composed of fine to medium-grained silicates to an approximate elevation of -5 to -15 feet NGVD. These organic and sandy soils are separated by a calcareous mud in places (case hardened cap rock) which varies in thickness from one foot along the western perimeter to six feet along the L-7 levee. Approximately 25 feet below land surface to the base of the aquifer, at approximately -200 feet NGVD, is a unit consisting of poorly sorted and inter-collated sandstone, shells, limestone, calcareous clays, and silts.

Water levels were measured semi-monthly from December 5, 1994 to March 29, 1996 and monthly from April 15, 1996 to December 16, 1996. Water levels varied approximately two feet between the seasonal high and low. The average surface water stage difference between the WCA-1 and ENR is approximately five feet.

Seepage flow into the ENR project site emerges to the surface along the toe of the L-7 levee between the inflow and outflow pump stations, and is subsequently collected by 21 culverts. Flow through these culverts was measured semi-monthly from August 19, 1994 to March 3, 1996 and monthly from April 15, 1996 to December 18, 1996. The average of the sum of 47 seepage measurements from 21 culverts was 7.44 cfs or 4.81 million gallons of water a day.

Although water quality data was collected, and the results tabulated for inclusion in the appendices, a detailed interpretation and analysis of water quality data is not included in this report.

TABLE OF CONTENTS

	Page
EXECUTIVE SUMMARY	i
LIST OF FIGURES	iv
LIST OF TABLES	iv
ACKNOWLEDGEMENTS	v
1.0 INTRODUCTION	1
1.1 Background	1
1.2 Purpose and Methods	1
1.3 Site Description	1
2.0 GEOLOGY	4
2.1 General Description of the Geology.....	4
2.1a L-7 Levee	4
2.1b Perimeter Levee.....	6
2.2 Geophysical Logging	6
3.0 MONITORING WELL CONSTRUCTION	8
3.1 L-7 Levee	8
3.2 Perimeter Levee.....	8
4.0 GROUND WATER HYDROLOGY	11
4.1 Ground Water Levels	11
4.1a L-7 Levee	11
4.1b Perimeter Levee.....	14
4.1c Permeability, Slug and Aquifer Performance Test Methods and Data ..	14
5.0 DIRECT SEEPAGE MEASUREMENTS	17
5.1 Methodology	17
6.0 WATER QUALITY	24
7.0 CONCLUSIONS	25
8.0 RECOMMENDATIONS	26
9.0 REFERENCES	27
APPENDIX A: Hydrogeologic Cross-Sections	29
APPENDIX B: Surface Water and Ground Water Level Graphs	43
APPENDIX C: Tabulated Surface Water and Ground Water Levels	51
APPENDIX D: Aquifer Performance and Slug Test Analyses	77
APPENDIX E: Ground Water Quality	121

LIST OF FIGURES

Figure Number	Description	Page
Figure 1.	Location of the Everglades Nutrient Removal Project Site in the Water Conservation Area (WCA 1).....	2
Figure 2.	Location of Monitoring Wells, Piezometers and Staff Gauges in the ENR Project.....	3
Figure 3.	Hydrogeological Cross-Section of the L-7 Levee.....	5
Figure 4.	Geophysical Log of ENR Well Site PO1.....	7
Figure 5.	The Typical Construction Design of a Monitor Well in the ENR Project.....	10
Figure 6.	Altitude of the Water Table in the Surficial Aquifer, June 1995.....	12
Figure 7.	Altitude of the Water Table in the Surficial Aquifer, October 1995.....	13
Figure 8.	Measured Seepage from 21 Culverts Located on the L-7 Levee.....	18
Figure 9.	Regression of Stage vs. Seepage Discharge from August 1994 to December 1996.....	23

LIST OF TABLES

Table Number	Description	Page
Table 1.	Well Construction Specifications for Monitoring Wells in the ENR.....	9
Table 2.	Depth of Cored and Tested Intervals of Monitoring Wells Requested in the Statement of Work.....	15
Table 3.	Results of the Slug and Laboratory Permeability Tests.....	16
Table 4.	Results of Aquifer Performance Test Analyses (from Ardaman & Assoc. 1994).....	17
Table 5.	Discharge Measurements Calculated for Each Culvert.....	19

ACKNOWLEDGEMENTS

The author would like to acknowledge Janet Wise and Diane Bello-Smith for creating and revising the graphics for this report. In addition, gratitude is expressed to Pete Dauenhauer, David Demonstranti, Nancy Moore and Tracey Reagan for collecting water levels and water quality. Additional thanks is extended to the report reviewers, Wossenu Abteu, Linda Lindstrom, John Lukasiewicz and Hedy Marshall.

INTRODUCTION

1.1 Background

Ground water moving into and out of the Everglades Nutrient Removal (ENR) project by way of seepage is a significant hydrologic component controlling the ENR annual water budgets. In order to assess the magnitude of seepage, a ground water monitoring well network was required. To meet that requirement, a Technical Memorandum and Scope of Work (Rohrer, 1992) was developed for the drilling of wells, testing of the aquifer properties and monitoring of water levels. The monitoring network was designed to determine the vertical and horizontal movement of ground water between Water Conservation Area 1 (WCA-1), the ENR project and the seepage canal located on the perimeter of the site. Once the monitoring wells were installed and the water level data analyzed, twelve (12) steady-state, cross-sectional, two-dimensional models were developed to evaluate the distribution of seepage. Preliminary results of this modeling effort were provided to South Florida Water Management District departments responsible for the operation of the ENR project and to various District consultants and contractors.

1.2 Purpose and Methods

The purpose of this report is to summarize the information obtained during the design, construction and operation of the monitoring well network, including: 1) the design and specifications of the ground water monitoring wells, 2) a summary of the temporal ground water levels collected during the study period, 3) an evaluation of the hydrogeologic setting of the ENR project, and 4) an evaluation of the distribution of seepage across the L-7 levee. Information from this detailed study will assist in the design and construction of future Storm Treatment Areas (STAs) in South Florida.

During the installation of the monitoring wells, geologic data was collected and analyzed to interpret the geologic control on the distribution and movement of ground water. Ground water levels were then collected semi-monthly, and seepage emerging at the surface and collected through 21 culverts along the L-7 levee was measured. Water quality samples were collected on a quarterly basis for use in interpreting the interaction between surface and ground water, and to meet permit compliance requirements.

1.3 Site Description

The ENR project is a 3,818-acre experimental wetland constructed for the purpose of removing phosphorus and other nutrients from agricultural and urban runoff entering WCA-1 through the West Palm Beach Canal (C-51). The ENR project is the first demonstration-scale wetland treatment system and is the prototype for Stormwater Treatment Area (STA) technology. A total of six STAs are being designed and built to treat stormwater runoff from the Everglades Agricultural Area prior to discharge into the Everglades Protection Area. The experience gained from the ENR project will assist in optimizing the design and operation of these future STAs.

The ENR project site is located adjacent to the northwestern corner of Arthur R. Marshall Loxahatchee National Wildlife Refuge WCA-1 (**Figure 1**). The ENR project (**Figure 2**) is enclosed by an irregular 7.5-mile long perimeter levee on the north and west sides, and

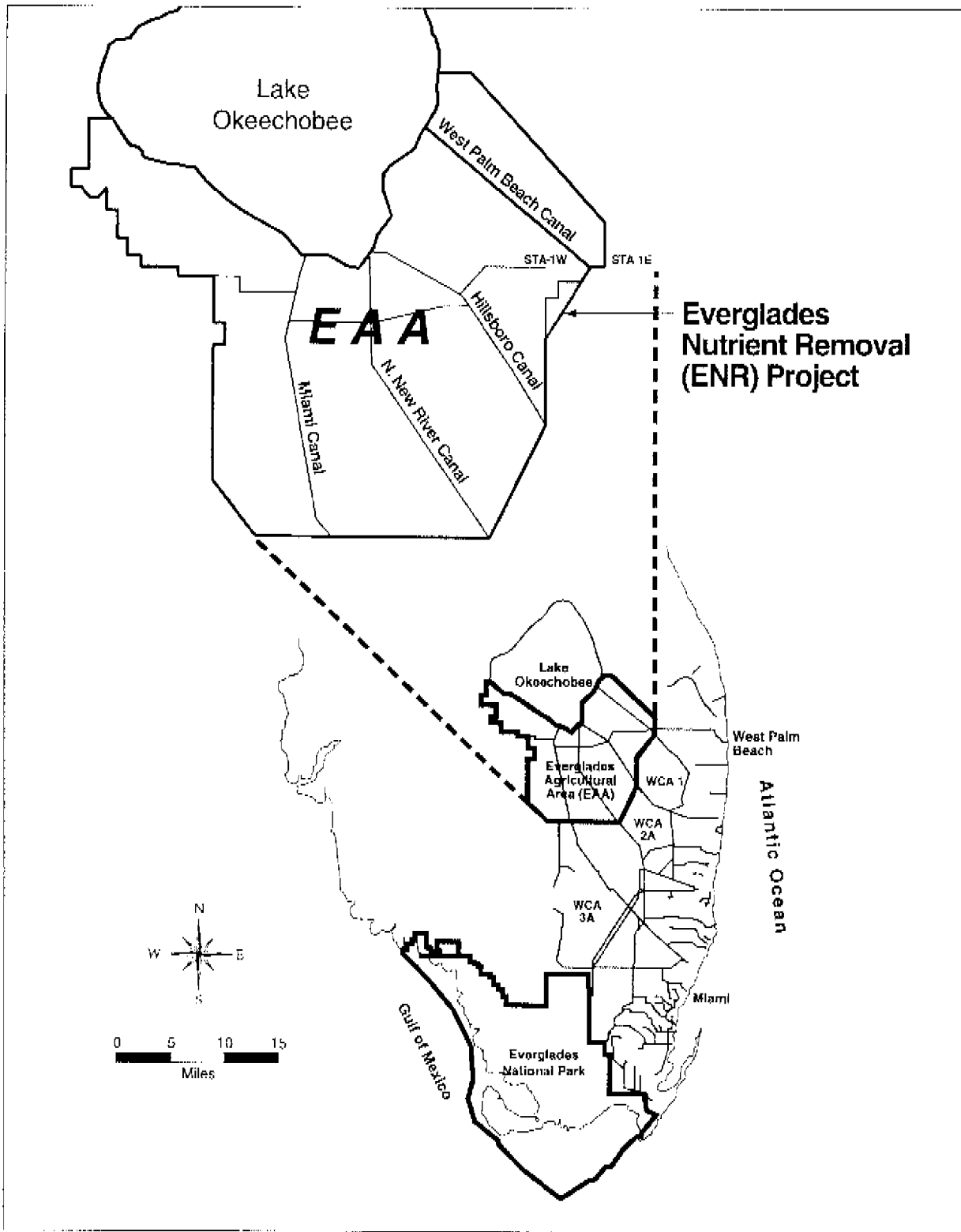

Figure 1. Location of the Everglades Nutrient Removal Project Site in the Water Conservation Area (WCA-1).

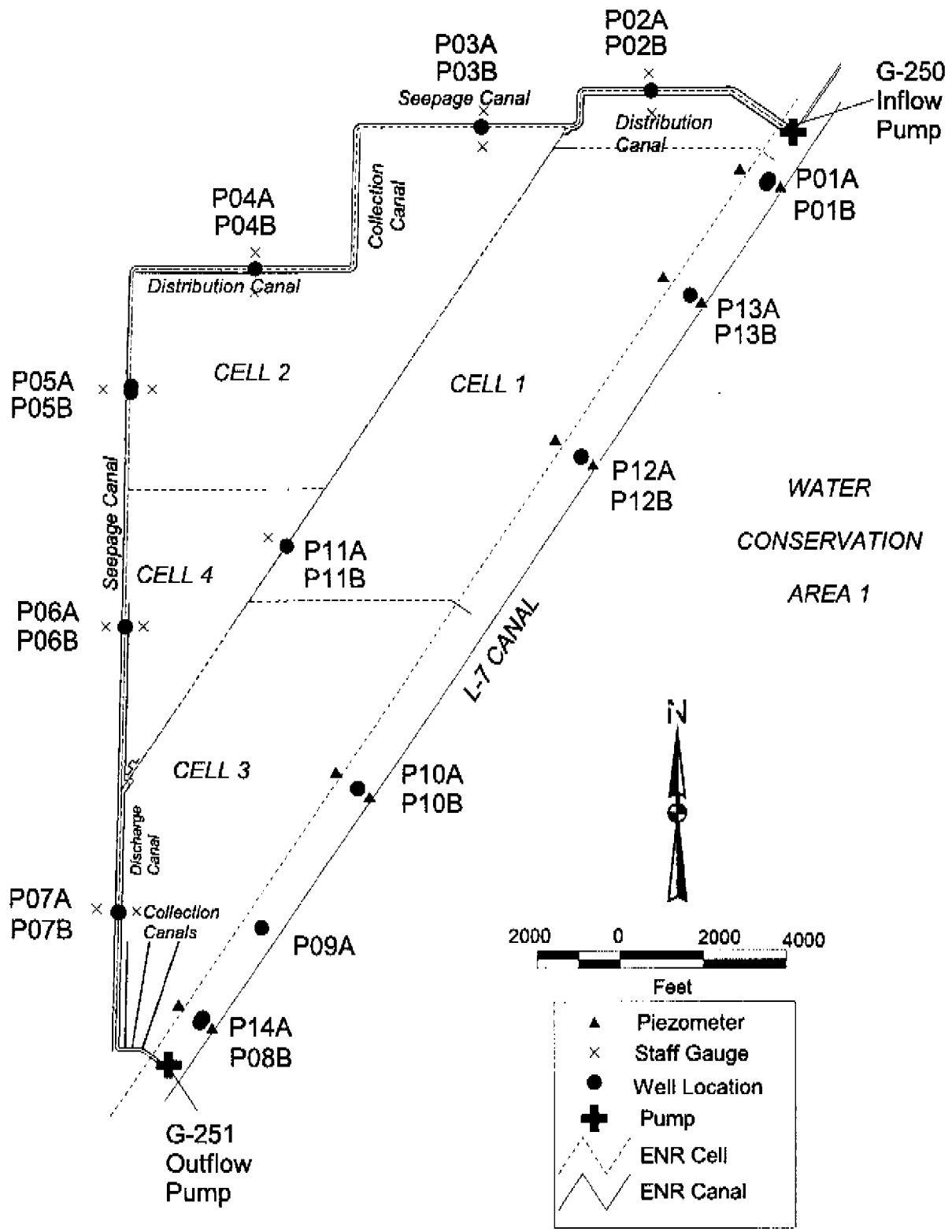

Figure 2. Location of Monitoring Wells, Piezometers and Staff Gauges in the ENR Project.

approximately 5.1 miles of levee referred to as the L-7 that separates WCA 1 from the ENR project. The enclosed area is subdivided by a system of internal levees into a buffer cell and four treatment cells. The buffer cell distributes inflow to two treatment cells (cells 1 and 2), which is then directed to two other cells called polishing cells (cells 3 and 4). An interior levee separates cells 1 and 3 from cells 2 and 4, and also serves as an electric power transmission corridor for Florida Power and Light. Each cell is maintained at an optimal stage for plant growth. Water is delivered to the ENR project in pulses according to a schedule intended to mimic the S-5A Pump Station. Water is drawn into the ENR project from the West Palm Beach Canal (C-51) through a supply canal to the inflow pump station (G 250).

Land surface is relatively flat in the ENR project with an average ground elevation of 10 feet (NGVD). The average elevation of the L-7 levee is 22 feet (NGVD) and the perimeter levee is approximately 16 feet (NGVD).

GEOLOGY

2.1 General Description of the Geology

The Surficial Aquifer System underlying the ENR is reported to be nearly 200 feet thick and consists of formations ranging in age from the upper Miocene to the Pleistocene (Miller, 1988). The aquifer system is composed of sand, sandstone, silty marl and limestone assigned to the Pleistocene aged Fort Thompson formation, Anastasia formation, and the Pliocene and Pleistocene Caloosahatchee marl.

The general lithology of the Surficial Aquifer System underlying the site can be subdivided into four (4) distinct types. A four-to-five foot thick layer of organic peat covers the entire ENR site. The underlying sand is composed of fine to medium-grained silicates, which extends to an approximate elevation of -5 to -15 feet below NGVD. Between the organic and sandy soils is usually a layer of calcareous mud, which in places is lithified to dense limestone (cap rock). The thickness of this cap rock varies from one foot, near sites P05 and P06 located on the western perimeter levee, to six feet along the L-7 levee. The lowermost unit extends from approximately -30 NGVD to the base of the Surficial aquifer at approximately -200 feet NGVD and consists of poorly sorted and inter-collated sandstones, shells, limestone, calcareous clays, and silts.

2.1a L-7 Levee

The L-7 levee is constructed of dredged material excavated from a borrow canal located adjacent to the levee. The dredged material was placed on top of the existing peat layer and built up to the present elevation. **Figure 3** shows a hydrogeologic cross section along the length of the L-7 levee. Continuous cuttings taken during the drilling of monitoring wells P01 and P14 (-76 and -42 feet NGVD, respectfully) show a 2-foot sand thick layer just below the cap rock between -5 to 7 feet NGVD. Gray limestone containing mollusk shell and fine-grained phosphate extends below the cap rock to approximately -35 feet NGVD. This is underlain by tan to gray limestone

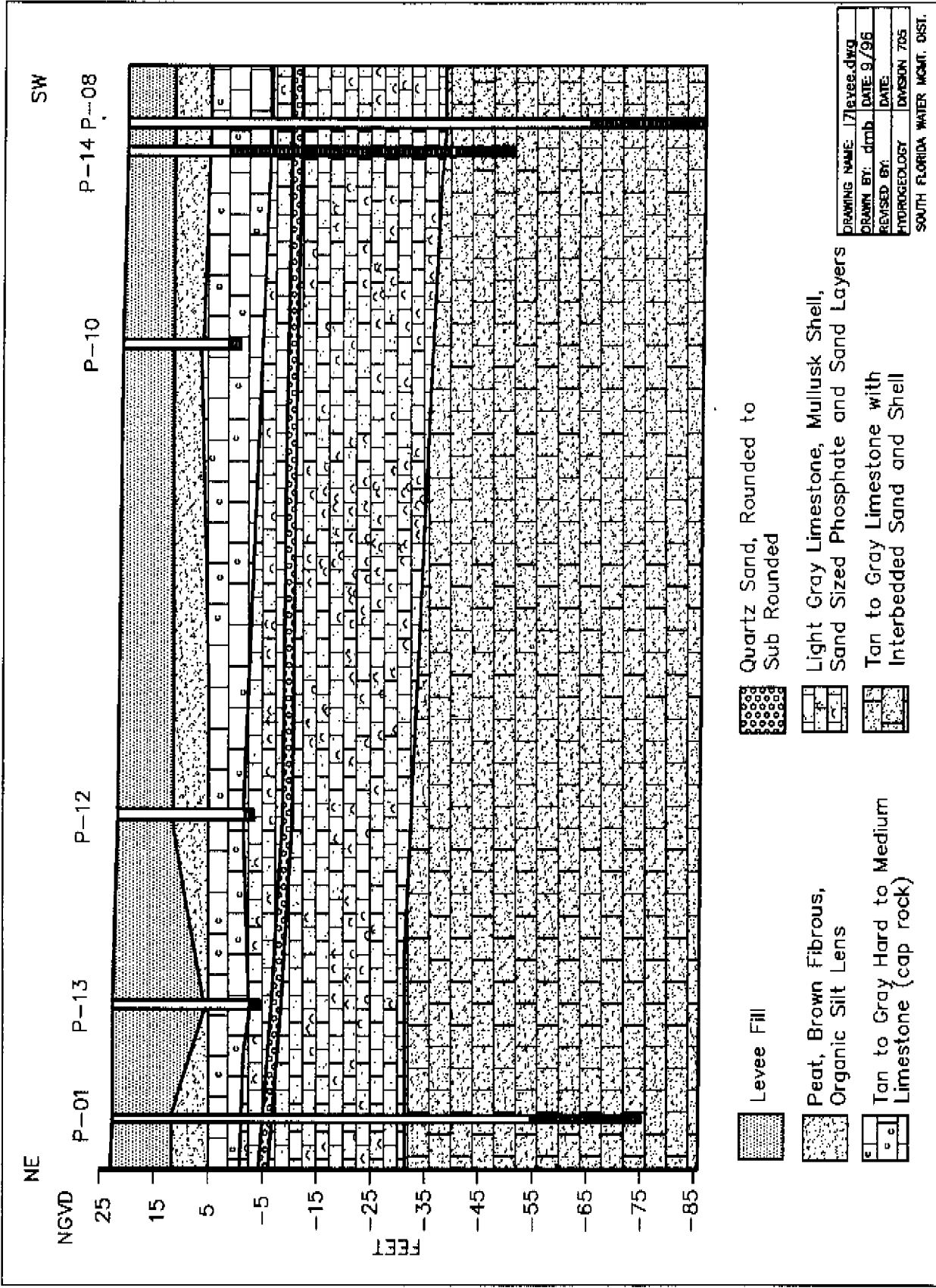

Figure 3. Hydrogeological Cross Section of the L-7 Levee

with inter-bedded sand and shells. It is interesting to note that during drilling, between the cap rock and the peat layer located approximately 20 feet below the top of the L-7 levee (5 feet NGVD), a void of approximately 6-8 inches thick was encountered. This void and the cap rock is most likely a result of mild organic acids leached from the peat layer, dissolving the limestone at the contact and redepositing the calcium carbonate between the peat and the limestone to form a "cap rock". It is at this approximate depth that seepage from WCA 1 to the ENR project is observed.

2.1b Perimeter Levee

Unlike the L-7 levee, peat was removed from the foundation before the perimeter levee was constructed. In addition, the perimeter levee was constructed with a core made from crushed limestone that was packed before the levee was formed.

The core of the perimeter levee is constructed of material excavated from the adjacent seepage canal, which consisted of the consolidated Fort Thompson and Anastasia formations. The thickness of the levee core is generally 10-15 feet. Underlying the core are medium-grained silicates, poorly sorted sandstone, shell, limestone and calcareous clays and silts. The core of the levee provides stability and increases the flow path of seepage beneath the perimeter levee by eliminating excessively high gradients. The increased flow path reduces the amount of horizontal seepage that may flow through the levee. The embankment material is generally comprised of the organic soils excavated near the site (Burns & McDonnell, 1991).

2.2 Geophysical Logging

Wells P01 and P08, located on the L-7 levee, were geophysically logged by District staff to verify depths and correlate the various aquifer units between the wells. The geophysical logs of P01 are juxtaposed on the stratigraphic section and shown in **Figure 4**. The geophysical logs most frequently used for evaluation and correlation of aquifer lithologic and fluid characteristics were: Natural Gamma, Neutron Porosity, 16 to 64 inch Normal Resistivity, and six foot lateral. The Natural Gamma log is a tool used to detect natural gamma radiation given off by the layers of sediment and rock present in the wall of a well. Geologic formations normally exhibit similar signatures within a given area. The Neutron Porosity log shows variation in the hydrogen content within the formation pore space. It characteristically attenuates with increased hydrogen content, and, therefore, indicates the presence of water within the pore space. Electric logs (16-64 inch, 6 foot Lateral and Spontaneous Potential) detect changes in the composition of the rock matrix and formation fluid. In monitoring well P01 at approximately -34 feet NGVD, the limestone formation was divided into upper and lower zones based on lithologic characteristics from samples taken above and below this unit while drilling and the signatures of the logs.

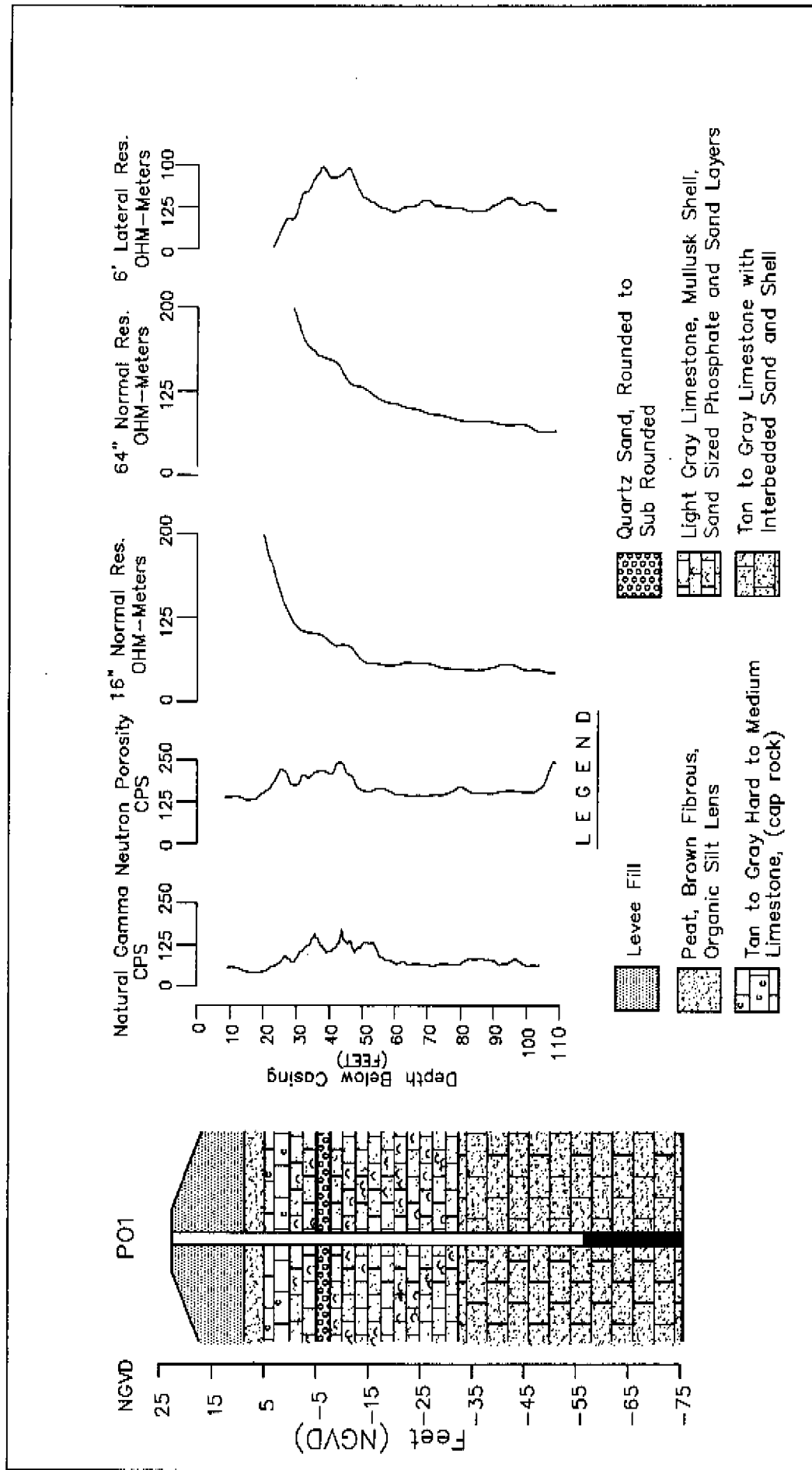

Figure 4. Geophysical Log of ENR Well Site P01

MONITORING WELL CONSTRUCTION

The locations of all monitoring wells constructed for this study are shown in **Figure 2**. **Table 1** provides well construction specifications for each of the monitoring wells installed at the ENR project. This table also provides latitude and longitude, total depth and screened interval depths in feet NGVD for each well. Each well screen was packed with 6/20 silica sand. All 2-inch wells have one foot of bentonite clay between the silica sand and the portland cement that completed the well to the surface. The 8-inch wells have two feet of clay overlying the silica sand. Each well was developed until the water was clear indicating the suspended sediments were removed. **Figure 5** shows the typical construction of a monitor well in the ENR project.

3.1 L-7 Levee

The deeper wells, P01 and P08 (-77.25 and -76.03 feet NGVD deep, respectively), were drilled using the mud rotary method (Appendix A, Figures A-1 and A-8). The mud used in drilling was an environmentally safe, water soluble mixture that breaks down in 24 hours. This mud was used to minimize the impact of residuals not removed during well development and to prevent environmental damage.

Monitoring well P14A was drilled on the L-7 levee to a depth of -42.43 ft. NGVD (Appendix A, Figure A-12). This well monitors the deeper, more permeable aquifer below. This deeper aquifer was encountered while drilling the 100-foot well. P14A was drilled by mud rotary and screened from -0.43 feet to -40.43 feet NGVD.

Wells P10A, P12A, and P13A, also located on the L-7 levee, were drilled using the auger method and completed below the cap rock (Appendix A, Figures A-8, A-10, A-11). Monitoring wells P10B, P12B, and P13B, also located on the L-7 levee, were completed above the cap rock and were intended to intercept the near-surface water interaction between the ENR project and the WCA-1 (approximately 10 feet bls). The objective of these well clusters was to compare the vertical hydraulic gradient and the horizontal seepage effects from the WCA-1. Two 2-inch diameter wells, P08B and P11A&B (Appendix A, Figures A-12 and A-9), were installed along the L-7 levee and the Florida Power and Light Company (FPL) access road. Each of these wells was constructed of threaded 2-inch diameter, schedule 40 PVC casing with 0.020-inch slotted schedule 40 PVC screen (**Table 1**).

3.2 Perimeter Levee

Six clusters of two 2-inch diameter wells (P02A through P07B) were constructed along the centerline of the perimeter levee road. This perimeter levee road borders the ENR site on the west and north. Ten- to twelve-foot deep wells designated with the letter B (e.g. P02B) were completed into the levee's core material. These "core" wells were designed to intersect the potential flow paths exiting the ENR project through the levee and to verify the hydraulic effects of the levee core (Appendix A, Figures A-2 through A-7).

Wells designated with the letter A were completed into the inter-bedded sand and limestone formation beneath the cap rock layer, approximately 15-17 feet NGVD, and were

Table 1: Well Construction Specifications for Monitoring Wells in the ENR.

Monitoring Well Number	Well Location Comments	Latitude	Longitude	State Easting (2020 Datum) (ft)	Plane Northing (2020 Datum) (ft)	Ground Surface Elevation (ft NGVD)	Measuring Point (MP) of Casings (ft NGVD)	Depth of Well (ft)	Screen Length (ft)	Top of Screen From MP (ft)	Bottom of Screen Interval (ft)	Top of Well Screen (ft NGVD)
P01A	L-7 Levee	263914.2	802254.4	696480.7	843813.7	23.20	22.95	100.00	20.00	80.00	100.00	-57.05
P01B	L-7 Levee	263915.1	802253.8	696537.5	843895.8	22.98	22.75	93.00	20.00	73.00	93.00	-50.25
P02A	Perimeter Levee	263935.7	802424.3	693757.3	845964.9	17.30	17.05	21.40	2.00	19.40	21.40	-2.35
P02B	Perimeter Core	263935.7	802424.6	693757.3	845964.9	17.34	17.12	11.34	2.00	9.34	11.34	7.78
P03A	Perimeter Levee	263927.6	802508.8	689728.6	845126.1	16.14	15.92	22.80	2.00	20.80	22.80	-4.88
P03B	Perimeter Core	263927.6	802508.9	689728.6	845126.1	16.20	15.97	10.45	2.00	8.45	10.45	7.52
P04A	Perimeter Levee	263855.0	802608.4	684330.0	841818.6	16.37	16.11	22.40	2.00	20.40	22.40	-4.29
P04B	Perimeter Core	263855.0	802608.5	684330.0	841818.6	16.34	16.03	9.45	2.00	7.45	9.45	8.58
P05A	Perimeter Levee	263826.5	802641.2	681378.5	839922.7	16.25	16.06	27.90	2.00	25.90	27.90	-9.84
P05B	Perimeter Core	263826.5	802641.2	681378.5	839922.7	19.10	15.97	12.22	2.00	10.22	12.22	5.75
P06A	Perimeter Levee	263732.2	802642.9	681244.8	833441.5	16.33	16.08	20.80	2.00	18.80	20.80	-2.72
P06B	Perimeter Core	263732.2	802642.8	681244.8	833441.5	16.31	16.08	10.41	2.00	8.41	10.41	7.67
P07A	Perimeter Levee	263626.2	802644.9	681090.0	826778.7	15.11	14.91	26.50	2.00	24.50	26.50	-9.59
P07B	Perimeter Core	263626.3	802644.9	681098.4	826782.4	15.06	14.70	12.14	2.00	10.14	12.14	4.56
P08A	Perimeter Levee	263600.7	802644.9	683011.7	824209.0	19.98	19.25	100.00	20.00	80.00	100.00	-60.75
P08B	Perimeter Core	263600.7	802623.8	683011.7	824209.0	21.06	20.87	96.90	20.00	76.90	96.90	-56.03
P09A	Perimeter Levee	263624.8	802613.4	683946.2	826646.3	0.00	15.45	15.00	10.00	5.00	15.00	10.45
P10A	L-7 Levee	263654.7	802542.1	686772.1	829882.4	21.53	21.21	21.30	2.00	19.30	21.30	1.91
P10B	L-7 Core	263654.7	802542.1	686775.1	829880.7	21.43	21.26	15.50	2.00	13.50	15.50	7.76
P11A	L-7 Levee	263750.9	802600.5	685077.3	835345.2	15.11	14.84	26.30	2.00	24.30	26.30	-9.46
P11B	L-7 Core	263732.2	802589.8	685077.3	835345.2	15.11	14.79	9.25	2.00	7.25	9.25	7.54
P12A	L-7 Levee	263811.3	802442.9	692108.0	837435.0	22.59	22.42	23.90	2.00	21.90	23.90	0.52
P12B	L-7 Core	263811.2	802443.0	692102.1	837430.0	22.62	22.38	18.20	2.00	16.20	18.20	6.18
P13A	L-7 Levee	263846.4	802414.3	694685.6	841193.5	22.86	22.62	27.50	5.00	22.50	27.50	0.12
P13B	L-7 Core	263849.5	802413.5	694685.6	841193.5	22.85	22.61	19.92	2.00	17.92	19.92	4.69

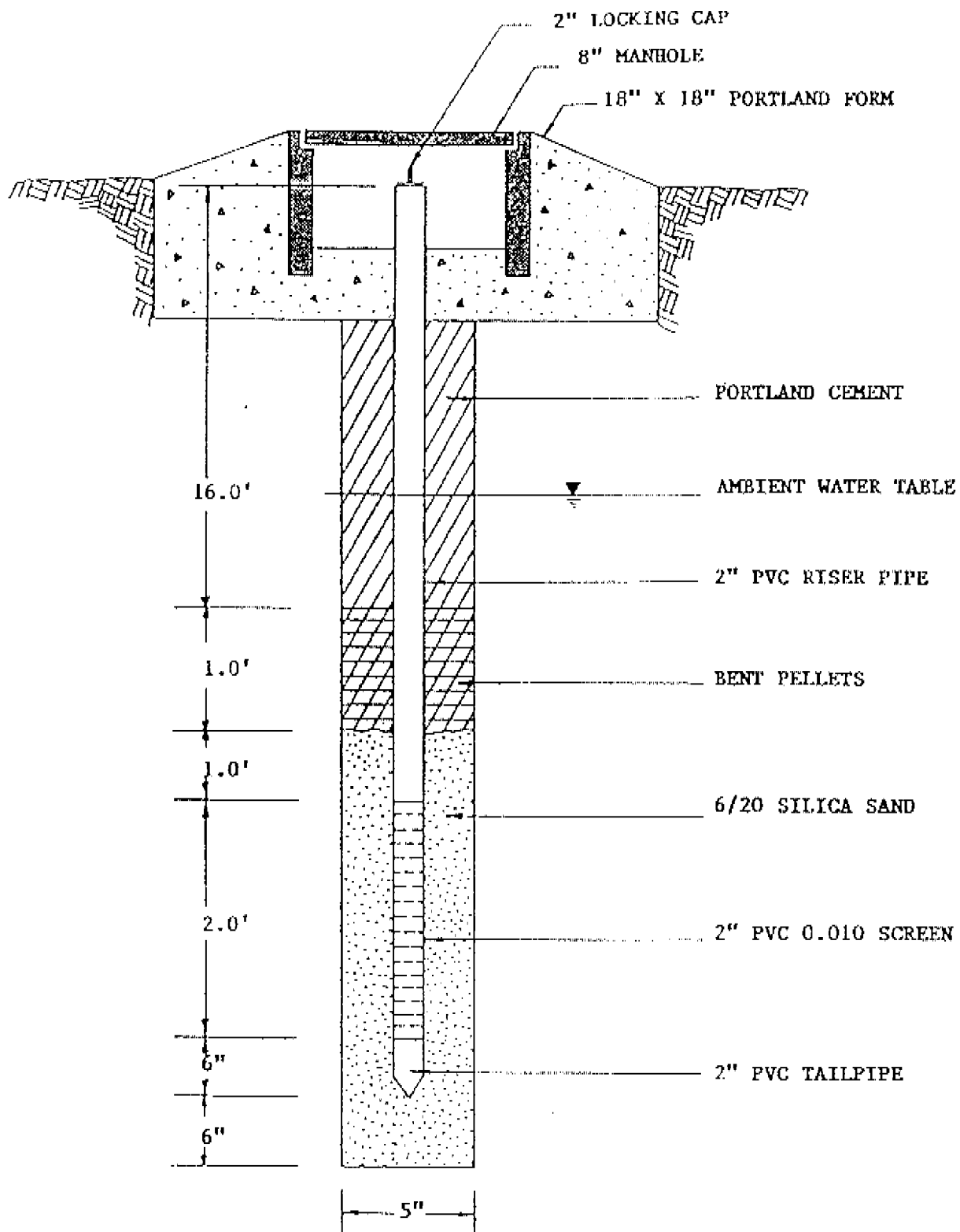

Figure 5. The Typical Construction Design of a Monitor Well in the ENR Project.

designed to intersect the deeper flow paths below the core in the levee. Each of these wells was constructed of threaded 2-inch diameter, schedule 40 PVC casing with 0.020-inch slotted schedule 40 PVC screen.

GROUND WATER HYDROLOGY

4.1 Ground Water Levels

Ground water levels were measured and recorded semi-monthly from December 5, 1994 to March 29, 1996 and monthly from April 15, 1996 to December 16, 1996. The water levels are listed in tables in Appendix C. Also listed in this table are the head differences between water levels measured in the 10-foot and 20-foot deep wells, and water level differences between the stages in the ENR, WCA-1 and seepage canal. Ground water levels and stage elevations were measured at the same time. **Figures 6 and 7** are contour maps showing seasonal effects on water table elevations below the cap rock for June 15, 1995 and October 10, 1995. During the seasonal high (October), ground water levels were approximately two feet higher than they were during the seasonal low along the L-7 levee. This correlated with an increase in stage in WCA-1. The effects of WCA-1 water levels on the ENR decrease with distance from the L-7 levee along the FPL power line access road near P11A&B. The contours also show that the general direction of ground water flow is from east to west, primarily because of the higher stages maintained in WCA-1 relative to the ENR.

4.1a L-7 Levee

Monitoring wells, P01A&B, P10A&B, P12A&B, P13A&B, P14A, and P08B, located along the L-7 levee, were designed to measure the effects of water levels in WCA-1 on seepage into and out of the ENR project. Ground water levels in these wells were plotted along with stage elevations in the WCA and ENR in **Figures B-1, B-9, B-11, B-12, and B-13** in Appendix B. Wells P01A and P14B were completed to -77.05 feet and -42.43 feet NGVD, respectively. Water levels measured in these wells are used to determine the interaction between two different flow zones identified in the Surficial aquifer. Wells P01A and P01B were completed at this same depth and were used to test the performance of the aquifer. These wells should have the same water level. However, the historical trend shows that P01B (2-inch observation well) shown in Appendix B, **Figure B-1** is approximately 0.26 feet higher than P01A (test well). This is most likely due to drilling mud that was not adequately flushed out and clogged the casing screen, thereby reducing the pressure in the well.

Average annual water levels in the deeper wells are generally lower than water levels in the shallower wells, suggesting that water in surface and shallow subsurface zones is recharging deeper zones. Wells P13B, P12B, and P10B monitor water levels above the cap rock, and wells P13A, P12A, and P10A monitor water levels below the cap rock (see Appendix B, **Figures B-12, B-11, and B-9**). With the exception of wells P12A&B, water level differences between these particular wells indicate a hydraulic separation caused by the confining nature of the cap rock. This may be because the wells do not adequately isolate the cap rock or because the cap rock at

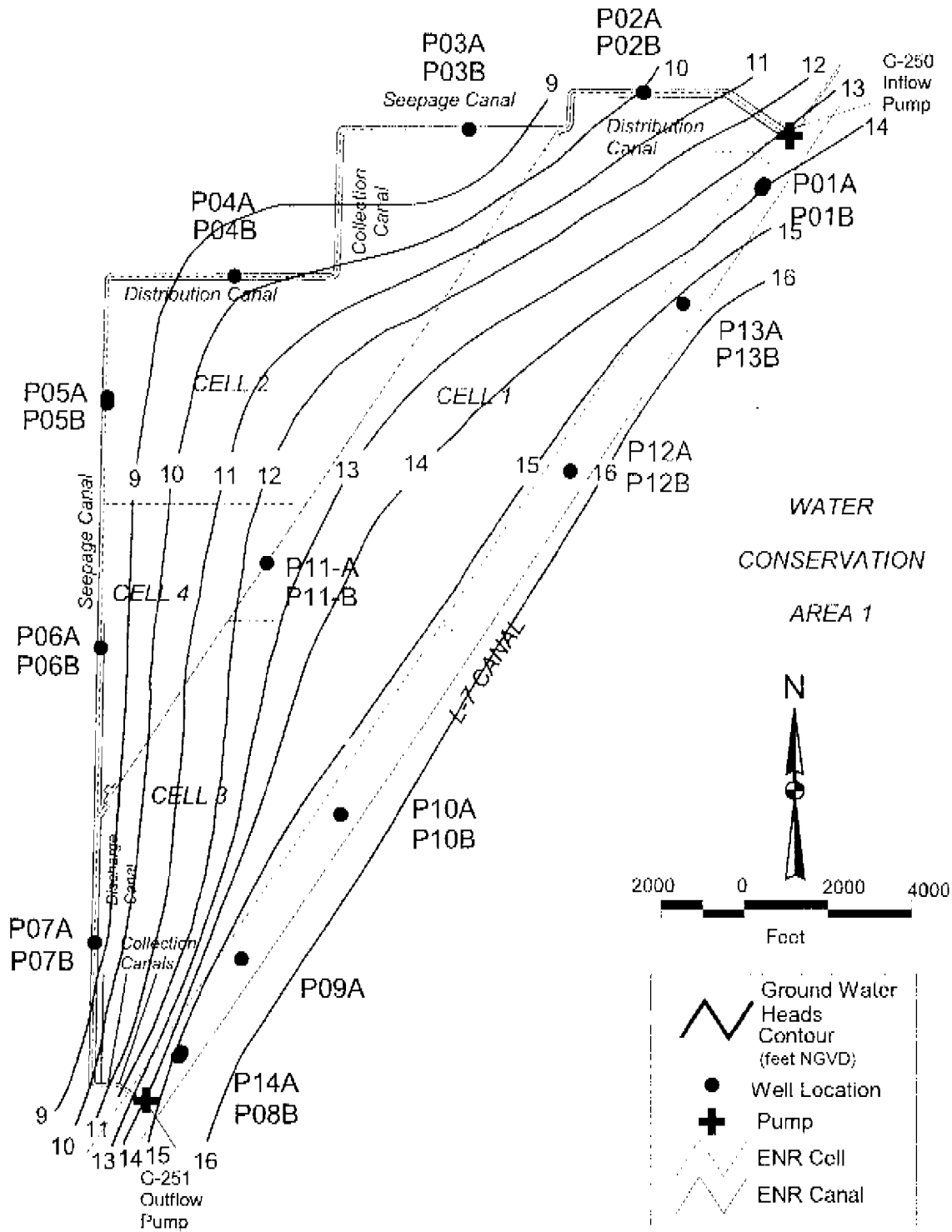

Figure 6. Altitude of the Water Table in the Surficial Aquifer, June 1995.

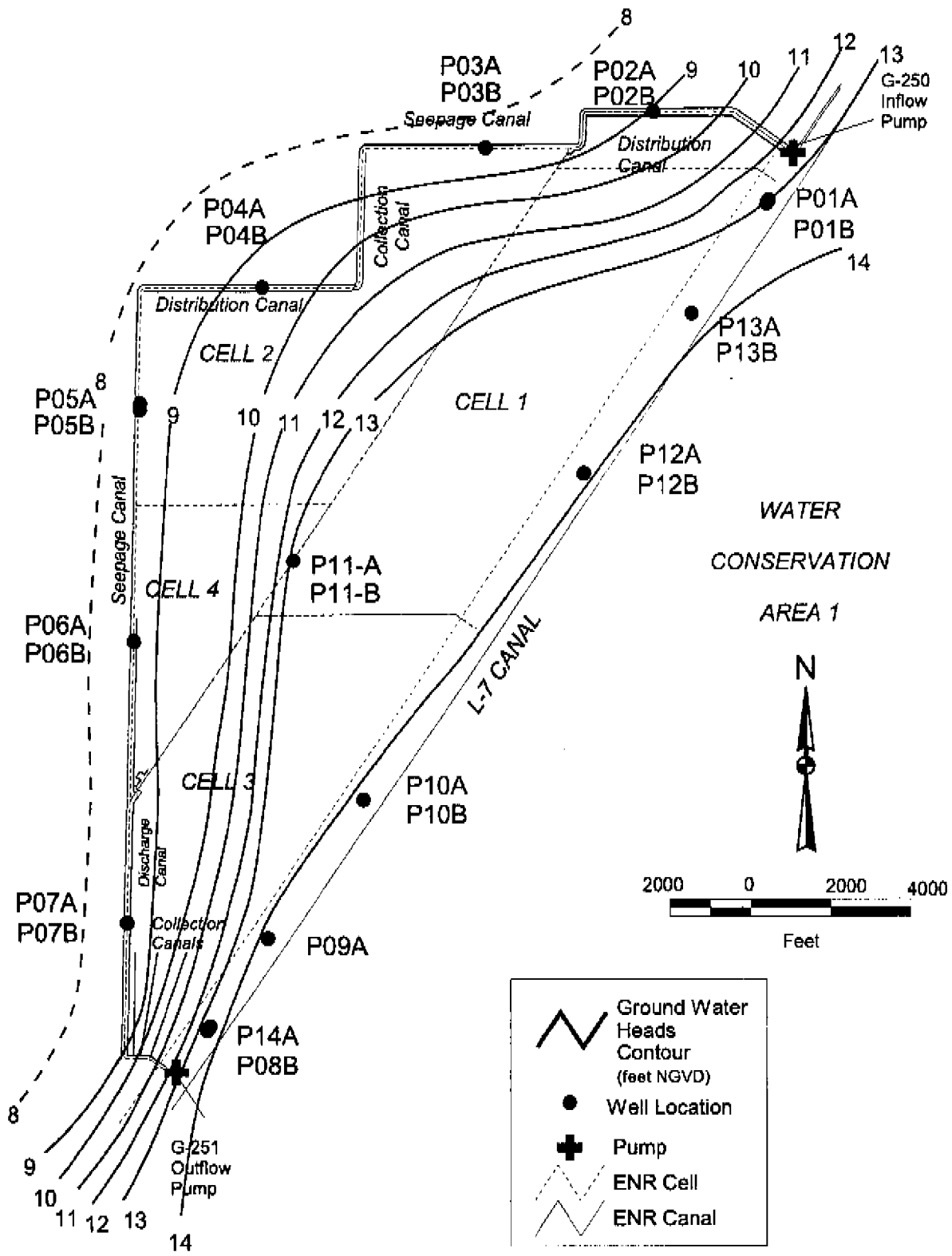

Figure 7. Altitude of the Water Table in the Surficial Aquifer, October 1995.

this location has a higher vertical hydraulic conductivity and is not as consolidated as it is at other locations in the ENR project.

4.1b Perimeter Levee

Wells P02A&B, P03A&B, P04A&B, P05A&B, and P07A&B are located along the perimeter levee (see Appendix B, Figures B-2, B-3, B-4, B-5, B-7). Wells designated with the letter "B" are 10-feet in depth and are completed in the core of the perimeter levee with a 2-foot slotted screen. These wells were designed to observe how well the levee core material blocks horizontal seepage escaping from the ENR project into the seepage canal. Those wells designated with the letter "A" are completed below the cap rock. Water levels measured in wells P02A&B, P03A&B, P05A&B, and P06A&B (Appendix B, Figures B-2, B-3, B-4, and B-5), are typically higher in the shallow wells, indicating a predominantly downward gradient along the western boundary.

Figures B-4 and B-7 (Appendix B) are hydrographs of wells P04A&B, and P07A&B. Each hydrograph shows that the water level in the deeper well is higher than that of the shallower well, suggesting that ground water is seeping upward. However, the difference in the water levels is most likely due to the head difference between surface water stage in the ENR project, the water level in the seepage canal, and the confining nature of the levee core that reduces pore pressure which suppresses water levels in the shallower wells.

Wells P02A&B, P04A&B, and P07A&B are located adjacent to a distribution canal (Appendix A, Figures A-2, A-4, and A-7) that was dredged to assist flow in the distribution of surface water in the ENR. Monthly ground water levels were plotted along with stage elevations in the ENR and WCA and are provided in Appendix B, Figures B-2, B-4 and B-7).

It is interesting to note that water levels tended to decrease in wells P02B, P03B, and P06B (all completed in the levee core) during the seasonal high water level (October). These water levels, plotted in Figures B-2, B-3, and B-6 (Appendix B), exhibited dramatic fluctuations independent of the influence of stages in the ENR project and the seepage canal. This may be due to the seepage canal being shared with the adjacent property owner who is regulating water levels to optimize farm operations as well as the surface water management practices of the ENR project.

4.1c Permeability, Slug and Aquifer Performance Test Methods and Data

Table 2 lists the wells and intervals cored and tested along with their corresponding total depth of screened interval and method of drilling. Eighteen split- spoon core samples were selectively collected during the drilling of 25 monitoring wells. These samples were analyzed by Ardaman & Associates' lab to determine permeabilities. The permeability tests were conducted on cores taken from either the designated-screened interval or from a zone that was uniquely different from other sites based on the cuttings. The methods used to determine permeability are described as the constant head (CH) and falling head/rising tail (FHRT) methods, which were performed in accordance with ASTM D-5084. Each sample was placed in a latex membrane and mounted in a triaxial-type perimeter. Each sample was then confined under an average isotropic effective consolidation stress of four pounds per square inch, and permeated with de-aired water

Table 2. Depth of Cored and Tested Intervals of Monitoring Wells Requested in the Statement of Work.

Well Number	Station Number	Depth of Well (ft bls)	Core Intervals (ft)	Screened Intervals (ft)	Drill Method
PO1A	L-7 Levee(north)	100	no core required	80-100	mud rotary
PO1B	L-7 Levee(north)	93	no core required	80-100	mud rotary
PO2A	358+00	21.4	16-18 20-22	19-21.3	auger/core
PO2B	358+00	11.34	6-8 8-10 11-14	9-11	core
PO3A	286+00	22.8	18-20	20-22.36	auger
PO3B	286+00	10.45	no core required	8-10	auger
PO4A	217+00	22.4	18-20	20-22	auger/core
PO4B	217+00	9.45	8-10	8-10	core
PO5A	151+00	27.9	14-16	26-28	auger/core
PO5B	151+00	12.22	12-14	10-12	core
PO6A	88+75	20.8	no core required	19-21	auger
PO6B	88+75	10.41	no core required	7.5-10	auger
PO7A	30+00	26.5	24-26	24-26	auger/core
PO7B	30+00	12.14	10-12	8-12	core
PO8A	L-7 Levee(south)	100	no core required	80-100	mud rotary
PO8B	L-7 Levee(south)	96.9	no core required	80-100	mud rotary
PO9A	L-7 Levee(middle)	15	0-15	5-15	core
P10A	L-7 Levee	21.3	8-10 10-12 13-15	19-21	auger/core
P10B	L-7 Levee	15.5	6-8	13-15	core
P11A	FPL Easement	26.3	18-20 24-26	24-26	
P11B	FPL Easement	9.25	8-10	8-10	core
P12A	L-7 Levee	23.9	21.5-23.5	21.5-23.5	auger/core
P12B	L-7 Levee	18.2	16-18	16-18	core
P13A	L-7 Levee	27.5	25-27	23-27	auger/core
P13B	L-7 Levee	19.92	0-10	17.5-19.5	core
P14A	L-7 Levee	63	22-60	22-60	core
P14B	L-7 Levee	62	22-60	22-60	mud rotary

under a back pressure of a minimum 95 feet per square inch, using average applied hydraulic heads across the sample ranging from 1.18 to 11.81 inches of water (Ardaman, 1995). Satisfactory saturation of some of the samples prior to permeation was verified by a B-factor greater than 95%.

Slug tests were also performed on each of the 10 and 20-foot wells, the results of which are provided in Appendix D. The slug test procedures followed those outlined by H. Bouwer and R.C. Rice, 1976. Water level measurements were recorded with a HERMIT SE2000 Data Logger. **Table 3** lists the wells tested and results of the slug tests and the laboratory permeability tests.

Table 3. Results of the Slug and Laboratory Permeability Tests.

Well Number	Depth of Interval Tested (ft bls)	Depth To Water in Feet (static)	Hydraulic Conductivity Obtained from Slug Tests (ft/day)	Hydraulic Conductivity of Cores Obtained from Lab Tests (ft/day)
P02A	19.3 - 21.3	7.21	20.1600	
P02B	9.34 - 11.34	5.97	0.0416	
	16 - 18			0.0179
	20 - 22			0.0709
P03A	20.36 - 22.36	7.44	149.7600	
P03B	8.45 - 10.45	4.42	103.6800	
P04A	20.36 - 22.36	6.56	17.2800	
P04B	7.45 - 9.45	6.61	0.2390	
	8-9			0.0025
	10-11			0.0002
	20-21.6			0.2438
P05A	25.88 - 27.88	6.93	79.2000	
P05B	10.22 - 12.22	6.81	2.0160	
	12 - 14			0.0077
	14 - 16			0.0011
	18 - 20			0.1247
	26 - 28			0.0224
P06A	18.7 - 20.7	7.41	6.6240	
P06B	8.41 - 10.41	5.99	2.3040	
P07A	24.48 - 26.48	6.20	47.5200	
P07B	10.14 - 12.14	6.39	0.2160	
	10 - 12			0.0164
	24 - 26			0.1304
P10A	19.12 - 21.12	6.32	37.4400	
P10B	13.5 - 15.5	5.51	2.5920	
	19 - 21			0.0019
P11A	24.25 - 26.25	2.52	35.8560	
P11B	7.25 - 9.25	2.45	0.0488	
	4-6			0.0031
	21-23			0.0765
P12A	22.86 - 23.86	7.66	38.4480	
P12B	16.2 - 18.2	7.61	0.4291	
	16-18			0.0002
	21.5 - 23.5			0.1190
P13A	25.45 - 27.45	7.70	14.6880	
P13B	17.92 - 19.92	7.68	0.2837	
	17 - 19			0.0001
	25 - 27			0.0340

Aquifer performance tests (APT) were conducted by pumping the two deep 8-inch diameter wells (P01B and P14B) located on the L-7 levee. Ardaman & Associates also conducted these tests under contract by the District. The results of the APT are summarized in Table 4. Field data and slug test plots were performed by Ardaman & Associates, and are provided in Appendix D, Figures D-1, D-2, D-3, and D-4.

Table 4. Results of Aquifer Performance Test Analyses (from Ardaman & Assoc. 1994).

Theis Method					
Well Number	Total Depth (Ft.)	Sceened Interval (Ft. NGVD)	Transmissivity (Ft. ² /min)	Storativity (unitless)	Depth (Ft. NGVD)
P01B	100.25	-50.25 to -70.25	44.82	.00094	-70.25
P14B	62.37	-4.43 to -42.3	10.3	.00011	-41.20

Cooper-Jacob Method					
Well Number	Total Depth (Ft.)	Sceened Interval (Ft. NGVD)	Transmissivity (Ft. ² /min)	Storativity (unitless)	Depth (Ft. NGVD)
P01B	100.25	-50.25 to -70.25	44.89	.00094	-70.25
P14B	62.37	-4.43 to -42.3	9.375	.00015	-41.20

There is some uncertainty with how these values were analyzed and should be used with caution. Duplication of analyses with the field data did not replicate the same result that was reported. The pump used while testing P01A and P14B did not drawdown the water level adequately in the zone where these wells were completed. The zone of influence from pumping the well responded as a constant recharge boundary from the WCA-1. This happens when water from WCA-1 is replacing water pumped from the test well. As a result, the influence of drawdown measured in the monitoring well 100 feet away was only 0.2 feet.

DIRECT SEEPAGE MEASUREMENTS

5.1 Methodology

Seepage flow into the ENR project emerges at the surface along the toe of the L-7 levee, between the inflow and outflow pump stations. It is subsequently collected in 21 culverts. Discharge flow from the culverts were measured every two weeks from August 19, 1994 to April 4, 1996 and monthly from May 15, 1996 to December 18, 1996 (**Figure 8**). Ground water levels were also measured during this time period. This was done to assist in interpreting the relationship between ground water and surface water elevations and to assist in the interpretation of ground

water flow in the ENR project. Monthly measurements are still collected as required in the operational permit for the ENR project and reported in the Annual ENR Monitoring Report.

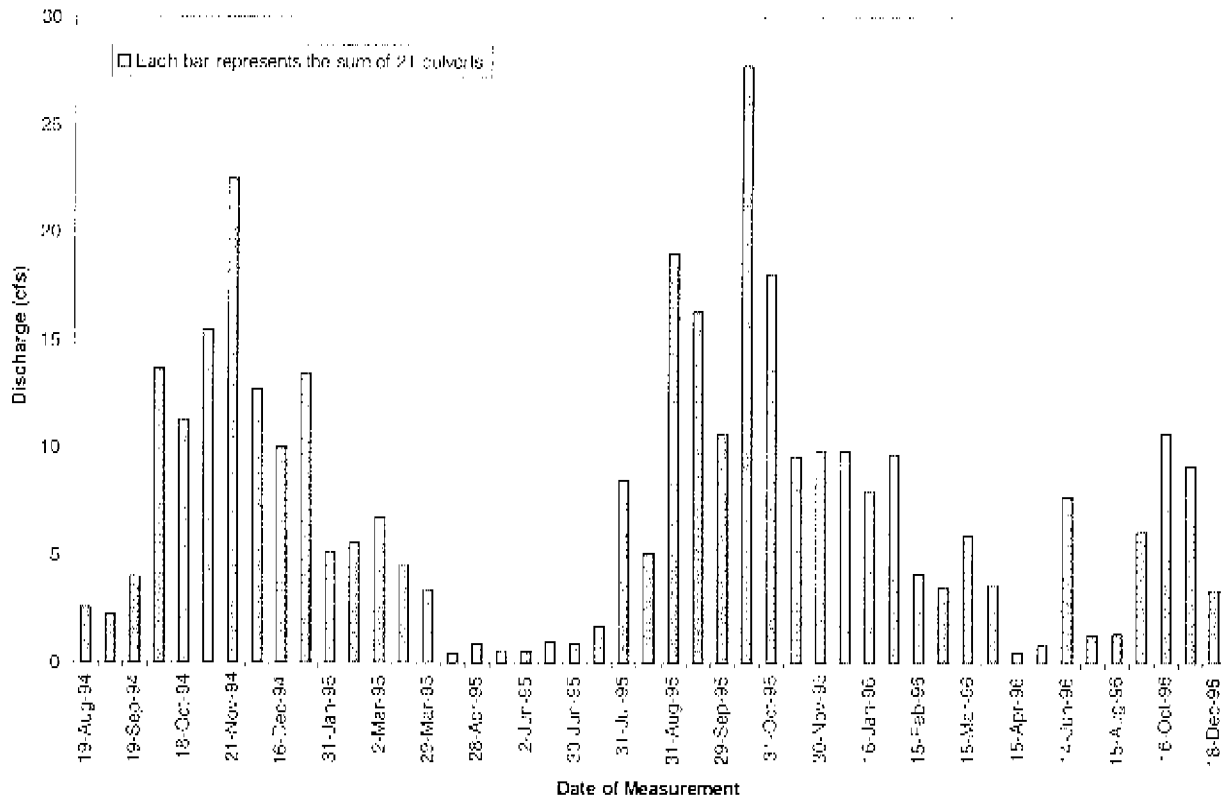

Figure 8. Measured Seepage from 21 Culverts Located on the L-7 Levee.

To quantify the volume of seepage, three different methods were examined to determine the most reliable one for the wide range of flows. These methods include: 1) volumetric flow measurement, 2) electromagnetic flow measurement, and 3) the float-flow measurement method. After extensive comparisons, the float flow measurement method was chosen because it provided the most consistent method for measuring the large variable flows. This technique consists of releasing a float at the inlet of the culvert and measuring the time (T) for the float to reach the outlet of the culvert, denoting L as the length of the culvert. The form of the equation used to calculate flow velocity (V) at the culvert is expressed as:

$$V = L / T \quad (1)$$

The wetted, cross-sectional area was determined for each culvert and multiplied by the velocity to obtain discharge. A correction factor, K, was defined to relate the surface velocity to the mean velocity.

Table 5 lists discharge measurements calculated for each culvert, with a corresponding total of the 21 culverts. Discharge calculated from the culvert ranges from a low of 0.41 cubic feet per second (cfs) or 0.26 million gallons per day (mgd) on April 19, 1995 to a high of 27.7 cfs on September 19, 1995 or 17.89 mgd. The average sum of 47 instantaneous seepage measurements from 21 culverts was 7.44 (cfs).

Table 5. Discharge Measurements Calculated for Each Culvert.

Date	Head Difference		Culvert 1	Culvert 2	Culvert 3	Culvert 4	Culvert 5	Culvert 6
	WCA	ENR	(cfs)	(cfs)	(cfs)	(cfs)	(cfs)	(cfs)
08/19/94	3.9500		0.0958	0.2280	0.0627	0.0014	0.0703	0.3478
08/30/94	4.0800		0.0878	0.2070	0.0378	0.0034	0.0413	0.2787
09/19/94	4.1300		0.0878	0.4135	0.1228	0.0366	0.1399	0.4178
10/05/94	5.0700		0.2010	1.0110	0.3770	0.6330	0.4150	0.8070
10/18/94	4.8700		0.1893	0.8377	0.4130	0.5252	0.2971	0.8592
11/02/94	5.4400		0.3870	1.1205	0.7281	0.8217	0.3184	0.9724
11/21/94	6.2600		1.2859	1.6412	0.6886	1.5217	0.6746	1.2888
12/01/94	5.0400		0.2786	1.1205	0.4303	0.7649	0.2971	0.8009
12/16/94	4.9500		0.8758	0.3184	0.8836	0.5285	0.4596	0.2971
12/29/94	5.4300		0.8870	0.5176	0.9140	0.6283	0.7934	0.3415
01/31/95	5.1300		0.4736	0.2011	0.2918	0.3586	0.1113	0.0843
02/16/96	5.3000		0.4478	0.1463	0.3206	0.3586	0.0564	0.0000
03/02/95	5.4300		0.7037	0.1351	0.4174	0.4303	0.1335	0.1192
03/20/95	4.9000		0.1319	0.3225	0.0564	0.5236	0.1653	0.1651
03/29/95	4.4200		0.3328	0.0917	0.2845	0.2396	0.0000	0.0399
04/19/95	3.8300		0.1781	0.0000	0.0000	0.0000	0.0000	0.0000
04/28/95	4.0400		0.2776	0.0000	0.1559	0.0000	0.0000	0.0000
05/16/95	4.1200		0.2586	0.0000	0.0662	0.0000	0.0000	0.0000
06/02/95	4.1900		0.1450	0.0000	0.0698	0.0000	0.0000	0.0000
06/15/95	4.4100		0.2209	0.0000	0.1405	0.0000	0.0000	0.0000
06/30/95	3.8800		0.2095	0.0000	0.0000	0.0000	0.0000	0.0000
07/14/95	4.3600		0.3003	0.0000	0.1593	0.0000	0.0000	0.0000
07/31/95	4.7300		0.7573	0.0781	0.5238	0.3586	0.1698	0.0843
08/17/95	4.2300		0.5026	0.0205	0.2111	0.0924	0.0000	0.0305
08/31/95	5.6400		1.6697	0.8769	1.1921	0.4488	0.9374	0.2786
09/20/95	5.3700		1.4940	0.4147	1.0358	0.6283	0.9374	0.2011
09/29/95	4.6800		0.8551	0.2047	1.1836	0.3686	0.3531	0.1004
10/19/95	5.9400		1.8934	1.5465	1.8166	0.6068	0.9374	0.4838
10/31/95	5.7000		1.4487	0.8634	1.2574	0.6966	0.4085	0.3199
11/15/95	4.8800		1.0346	0.3628	0.7518	0.5379	0.2171	0.1004
11/30/95	4.8600		0.4899	0.3628	0.8644	0.4404	0.0814	0.1399
12/18/95	4.6300		0.5728	0.3628	0.7885	0.3775	0.3602	0.1938
01/16/96	4.5900		0.5153	0.2145	0.8318	0.5285	0.1486	0.0843
01/31/96	4.3800		0.6809	0.2011	0.8898	0.7282	0.2186	0.1463
02/15/96	5.1300		0.4544	0.0700	0.3782	0.1535	0.0194	0.0382
03/04/96	4.9800		0.3345	0.0331	0.4980	0.0378	0.0163	0.0282
03/15/96	3.9700		0.5340	0.0871	0.8758	0.1535	0.0581	0.0753
03/29/96	4.3400		0.3705	0.0802	0.4731	0.0453	0.0464	0.0082
04/15/96	3.2900		0.0977	0.0000	0.0000	0.0000	0.0000	0.0000
05/15/96	4.0200		0.0860	0.0000	0.0000	0.0000	0.0000	0.0000
06/14/96	5.1100		0.4148	0.1694	0.8318	0.2047	0.3528	0.1004
07/18/96	3.5800		0.1098	0.0059	0.1700	0.0033	0.0000	0.0000
08/15/96	3.9900		0.1270	0.0000	0.2459	0.0000	0.0000	0.0000
08/18/96	4.6400		0.2353	0.1182	0.6157	0.2096	0.3278	0.1287
10/16/96	5.0000		0.4700	0.2300	0.7200	0.5900	0.4400	0.1300
11/15/96	4.7600		0.4100	0.1500	0.7000	0.6600	0.2000	0.0900
12/18/96	4.3400		0.1300	0.0500	0.2300	0.0900	0.0700	0.0500
Sum			23.5421	14.7768	23.2853	15.3297	10.2935	9.6298

Table 5. Discharge Measurements Calculated for Each Culvert (Continued).

Date	Head Difference WCA - ENR	Culvert 7 (cfs)	Culvert 8 (cfs)	Culvert 9 (cfs)	Culvert 10 (cfs)	Culvert 11 (cfs)	Culvert 12 (cfs)
08/19/94	3.9500	0.1185	0.0853	0.1756	0.1238	0.1505	0.1481
08/30/94	4.0800	0.0645	0.0313	0.0318	0.0827	0.1651	0.1800
09/19/94	4.1300	0.1342	0.0703	0.0837	0.1149	0.1551	0.1880
10/05/94	5.0700	0.4320	0.4830	1.6350	0.3429	0.9140	0.6430
10/10/94	4.8700	0.3985	0.3870	1.4050	0.2026	0.7067	0.5721
11/02/94	5.4400	0.4317	0.5713	1.8171	0.4872	0.9724	0.6235
11/21/94	6.2600	0.6323	0.6264	2.3227	0.4872	1.2580	0.9666
12/01/94	5.0400	0.4155	0.3294	1.9055	0.3814	0.6674	0.5845
12/16/94	4.9500	0.8009	0.3813	0.2122	1.2888	0.2228	0.5755
12/29/94	5.4300	0.7067	0.4709	0.3870	1.2888	0.2524	0.5721
01/31/95	5.1300	0.3415	0.1759	0.1399	0.5481	0.0705	0.2419
02/16/95	5.3000	0.5176	0.1671	0.0945	0.5045	0.0975	0.2684
03/02/95	5.4300	0.5713	0.2192	0.0781	0.7067	0.1238	0.3986
03/20/95	4.9000	0.5846	0.0946	0.2419	0.0533	0.1537	0.0340
03/29/95	4.4200	0.3415	0.1018	0.0680	0.3700	0.1073	0.1416
04/19/95	3.8300	0.0474	0.0000	0.0000	0.0000	0.0000	0.0000
04/28/95	4.0400	0.0882	n/a	0.0000	0.0000	0.0287	0.0000
05/16/95	4.1200	0.0703	n/a	0.0000	0.0000	0.0000	0.0000
06/02/95	4.1900	0.0670	0.0000	0.0000	0.0000	0.0178	0.0000
06/15/95	4.4100	0.1538	0.0000	0.0000	0.0000	0.0570	0.0000
06/30/95	3.8800	0.0000	0.0000	0.0000	0.0000	0.0000	0.0000
07/14/95	4.3800	0.1727	0.0484	n/a	0.1812	0.0847	0.0867
07/31/95	4.7300	0.8362	0.1906	0.1706	0.0724	0.1416	0.2942
08/17/95	4.2300	0.6814	0.1367	0.1537	0.5180	0.1393	0.2223
08/31/95	5.6400	1.1215	0.4290	0.4317	1.6504	0.5223	0.7944
09/20/95	5.3700	1.1215	0.3837	0.2071	1.7184	0.4144	0.8666
09/29/95	4.6800	0.9097	0.2800	0.2233	1.0552	0.3654	0.4313
10/19/95	5.9400	1.6257	0.7733	0.9241	2.9863	0.6724	1.6257
10/31/95	5.7000	0.9666	0.4805	0.5181	1.9167	0.5223	0.9083
11/15/95	4.8000	0.9097	0.3047	0.2639	1.2470	0.2684	0.3194
11/30/95	4.8600	0.9666	0.2960	0.1938	1.2013	0.2903	0.6630
12/16/95	4.6300	0.5006	0.2800	0.2639	1.3260	0.4145	0.5487
01/16/96	4.5900	0.8009	0.2410	0.1463	0.8581	0.2026	0.4434
01/31/96	4.3000	0.9185	0.2252	0.1938	1.0921	0.2764	0.7733
02/15/96	5.1300	0.5824	0.1754	0.1062	0.5973	0.1038	0.3047
03/04/96	4.9800	0.5006	0.1367	0.0305	0.4147	0.1192	0.0750
03/15/96	3.9700	0.7621	0.2039	0.0351	0.6039	0.1651	0.2485
03/29/96	4.3400	0.5591	0.1349	0.0541	0.4147	0.0659	0.1906
04/15/96	3.2900	0.1449	0.0000	0.0000	0.0000	0.0069	0.0000
05/15/96	4.0200	0.4418	0.0000	0.0000	0.0946	0.0269	0.0000
06/14/96	5.1100	0.8754	0.2145	0.1609	0.5825	0.1793	0.3297
07/16/96	3.5600	0.2858	0.0403	0.0536	0.1311	0.0306	0.0514
08/15/96	3.9900	0.1242	0.0704	0.0631	0.1697	0.0469	0.0000
08/16/96	4.6400	0.6809	0.0613	0.2308	0.4934	0.1238	0.2403
10/16/96	5.0000	0.9500	0.2100	0.5200	0.8500	0.3000	0.4800
11/15/96	4.7600	0.8700	0.3000	0.2200	0.8000	0.2700	0.4000
12/18/96	4.3400	0.5800	0.1900	0.0700	0.2400	0.0600	0.1000
Sum		25.8128	10.0013	16.2246	29.2881	11.9335	16.5125

Table 5. Discharge Measurements Calculated for Each Culvert (Continued).

Date	Head Difference WCA - ENR	Culvert 13 (cfs)	Culvert 14 (cfs)	Culvert 15 (cfs)	Culvert 16 (cfs)	Culvert 17 (cfs)	Culvert 18 (cfs)
08/19/94	3.9500	0.5923	0.0000	0.0000	0.0000	0.1890	0.1753
08/30/94	4.0800	0.4470	0.0000	0.0000	0.0000	0.1074	0.4147
09/19/94	4.1300	0.5176	0.0000	0.0000	0.0000	0.5277	0.5575
10/05/94	5.0700	1.0720	0.0000	0.0587	0.0362	1.7160	1.7250
10/18/94	4.8700	0.7401	0.0000	0.0000	0.0000	1.4615	1.2470
11/02/94	5.4400	1.0921	0.0000	0.0615	0.0413	1.7162	2.0172
11/21/94	6.2600	1.3628	0.0000	0.5176	1.5017	2.2093	1.9167
12/01/94	5.0400	0.8634	0.0000	0.1438	0.0000	1.4802	1.2470
12/16/94	4.9500	0.4143	0.7308	0.0000	0.0000	0.0000	0.5805
12/29/94	5.4300	0.5144	0.5575	0.0000	0.0000	0.0000	1.5017
01/31/95	5.1300	0.2527	0.4466	0.0000	0.0000	0.0000	0.3428
02/16/95	5.3000	0.2072	0.4615	0.0000	0.0000	0.0000	0.2300
03/02/95	5.4300	0.2310	0.6323	0.0000	0.0000	0.0000	0.1759
03/20/95	4.9000	0.1790	0.0917	0.0000	0.0000	0.0000	0.1505
03/29/95	4.4200	0.1863	0.3654	0.0000	0.0000	0.0000	0.0482
04/19/95	3.8300	0.0552	0.0000	0.0000	0.0000	0.0000	0.0000
04/28/95	4.0400	0.0030	0.1399	0.0000	0.0000	0.0000	0.0000
05/16/95	4.1200	0.0000	0.1399	0.0000	0.0000	0.0000	0.0000
06/02/95	4.1900	0.0000	0.0703	0.0000	0.0000	0.0000	0.0000
06/15/95	4.4100	0.0000	0.1694	0.0000	0.0000	0.0000	0.0000
06/30/95	3.8800	0.0000	0.4385	0.0000	0.0000	0.0000	0.0000
07/14/95	4.3600	0.0636	0.2622	0.0000	0.0000	0.0000	0.0000
07/31/95	4.7300	0.2572	0.5846	0.0000	0.0000	0.0000	0.8052
08/17/95	4.2300	0.2225	0.8573	0.0000	0.0000	0.0000	0.1036
08/31/95	5.8400	0.8625	1.0310	0.0000	0.1463	0.1240	2.1563
09/20/95	5.3700	0.6355	0.8592	0.0000	0.0000	0.0000	1.9332
09/29/95	4.8800	0.5227	0.9145	0.0000	0.0000	0.0000	0.7970
10/19/95	5.9400	1.1380	2.0524	0.0000	0.4466	0.9744	2.9883
10/31/95	5.7000	0.7628	1.5174	0.0000	0.0514	0.1054	1.9332
11/15/95	4.8800	0.5275	0.5481	0.0000	0.0000	0.0000	0.9744
11/30/95	4.8600	0.4833	0.8580	0.0000	0.0000	0.0000	0.5805
12/18/95	4.6300	0.4730	1.1500	0.0000	0.0000	0.0000	0.8039
01/16/96	4.5900	0.4143	0.7308	0.0000	0.0000	0.0000	0.3714
01/31/96	4.3800	0.4425	0.8634	0.0000	0.0000	0.0000	0.5805
02/15/96	5.1300	0.2960	0.4529	0.0000	0.0000	0.0000	0.0236
03/04/96	4.9800	0.2451	0.6476	0.0000	0.0000	0.0000	0.0040
03/15/96	3.9700	0.2930	0.6746	0.0000	0.0000	0.0000	0.3714
03/29/96	4.3400	0.2800	0.3628	0.0000	0.0000	0.0000	0.0620
04/15/96	3.2900	0.0080	0.1192	0.0000	0.0000	0.0000	0.0000
05/15/96	4.0200	0.1249	0.0000	0.0000	0.0000	0.0000	0.0000
06/14/96	5.1100	0.4425	0.7454	0.0000	0.0000	0.0000	0.7239
07/16/96	3.5600	0.1208	0.1529	0.0000	0.0000	0.0000	0.0000
08/15/96	3.9900	0.1208	0.1764	0.0000	0.0000	0.0000	0.0000
09/16/96	4.6400	0.3003	0.4317	0.0000	0.0000	0.0000	0.3294
10/16/96	5.0000	0.4800	0.7700	0.0000	0.0000	0.0000	1.0400
11/15/96	4.7800	0.4100	0.5800	0.0000	0.0000	0.0000	0.7300
12/18/96	4.3400	0.0500	0.2800	0.0000	0.0000	0.0000	0.1400
Sum		18.7070	21.8662	0.7828	2.2285	10.6111	29.5800

Table 5. Discharge Measurements Calculated for Each Culvert (Continued).

Date	Head			
	Difference WCA - ENR	Culvert 19	Culvert 20	Culvert 21
08/19/94	3.9500	0.0000	0.0000	0.0000
08/30/94	4.0800	0.0866	0.0000	0.0000
09/19/94	4.1900	0.1050	0.0000	0.0000
10/05/94	5.0700	0.7530	0.3690	0.0000
10/18/94	4.8700	0.6133	0.4064	0.0000
11/02/94	5.4400	0.7243	0.5301	0.0000
11/21/94	6.2600	0.4835	1.0956	0.0000
12/01/94	5.0400	0.2645	0.7422	0.0000
12/16/94	4.9500	0.7308	0.6450	0.2297
12/29/94	5.4300	0.8634	1.5017	0.7590
01/31/95	5.1300	0.4466	0.5277	0.0804
02/16/95	5.3000	0.3225	0.6588	0.6125
03/02/95	5.4300	0.7308	0.8012	0.1767
03/20/95	4.9000	0.5846	0.7307	0.2795
03/29/95	4.4200	0.2971	0.3183	0.0630
04/19/95	3.8300	0.0000	0.1287	0.0000
04/28/95	4.0400	0.1938	0.0000	0.0000
05/16/95	4.1200	0.0000	0.0445	0.0000
06/02/95	4.1900	0.1149	0.0639	0.0000
06/15/95	4.4100	0.1532	0.1054	0.0000
06/30/95	3.8800	0.1694	0.0551	0.0082
07/14/95	4.3600	0.1780	0.1694	0.0000
07/31/95	4.7300	0.9419	0.9744	0.3004
08/17/95	4.2300	0.5481	0.4831	0.1414
08/31/95	5.6400	1.5465	2.2003	0.5655
09/20/95	5.3700	1.5242	1.5017	0.3534
09/29/95	4.6800	0.5375	0.8760	0.8638
10/19/95	5.9400	1.3348	2.5776	0.5301
10/31/95	5.7000	1.1431	1.5242	0.7089
11/15/95	4.8800	0.6939	0.5805	0.0353
11/30/95	4.8600	0.7308	1.1512	0.6530
12/18/95	4.6300	0.6746	0.8769	0.0707
01/16/96	4.5900	0.6388	0.8052	0.0177
01/31/96	4.3800	0.4838	0.8769	0.0707
02/15/96	5.1000	0.1406	0.2298	0.0000
03/04/96	4.9800	0.1780	0.2011	0.0000
03/15/96	3.9700	0.5176	0.4653	0.0000
03/29/96	4.1400	0.2622	0.2476	0.0000
04/15/96	3.2900	0.0304	0.0458	0.0000
05/15/96	4.0200	0.1399	0.0000	0.0000
06/14/96	5.1100	0.5429	0.5805	0.1767
07/16/96	3.5600	0.1954	0.0579	0.0000
08/15/96	3.9500	0.1110	0.1171	0.0000
09/16/96	4.6400	0.8009	0.5805	0.1767
10/16/96	5.0000	1.1400	1.0400	0.2700
11/15/96	4.7600	1.1400	0.9400	0.3000
12/18/96	4.3400	0.3600	0.3900	0.3000
Sum		24.0852	28.2512	8.9345

A linear regression model (**Figure 9**) was developed to predict the component of seepage underneath the L-7 levee that flows through culverts using the difference between water levels from WCA-1 and the ENR project, and discharge measured from the culverts. In order to provide this relationship, water levels were collected at the same time seepage discharge was measured from the culverts. All seepage measurements (47) were used to calculate an $R^2 = 0.696$. The minimum and maximum head differences ranged from 3.29 ft. to 6.26 ft. The equation: - Head (ft.) = $4.05 + 0.0846 \times Q$ (cfs) suggests head differences of less than 4.05 feet will not emerge as direct seepage. It was observed that measured head differences as low as 3.83 feet produced discharge measurements of 0.41 cfs, indicating other variables, along with stage differences between the WCA-1 and ENR project control seepage. The regression curve (**Figure 9**) illustrates the wide variability between total discharge from 21 culverts and head differences between the WCA-1 and the ENR project for the operational period of record. The variation between data points for head difference and the specific measured discharge rates may be the result of measurement error.

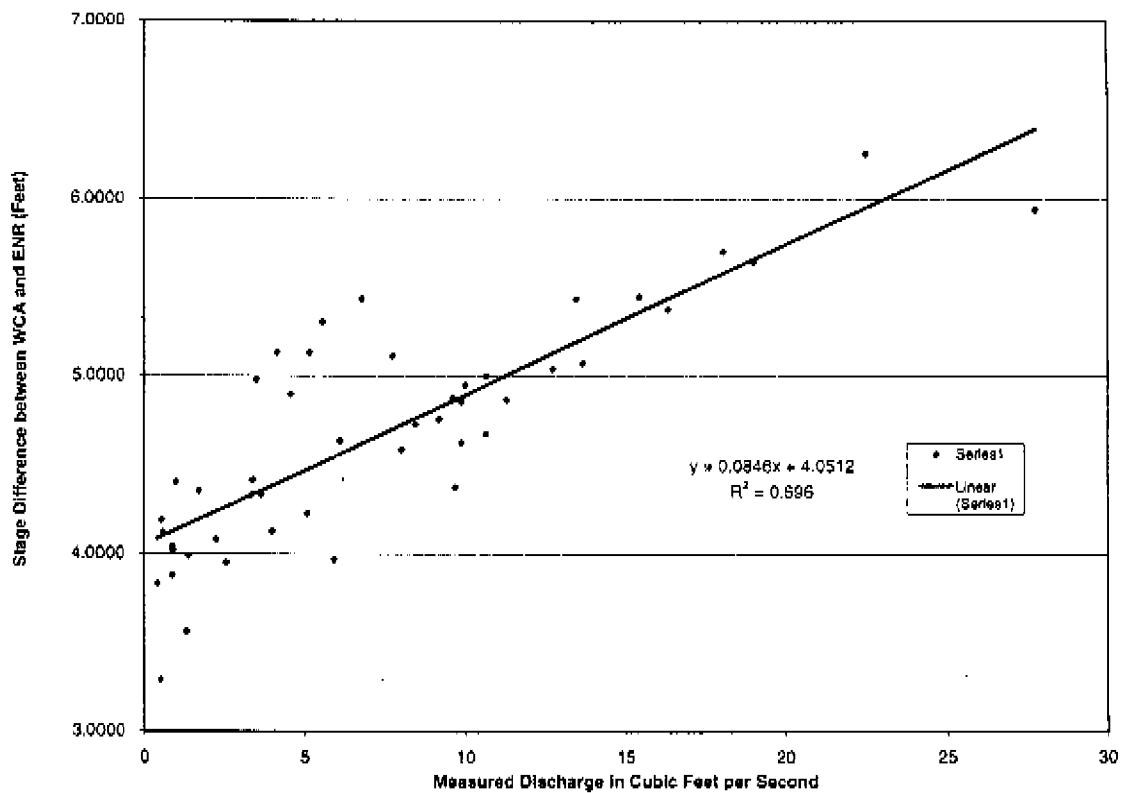

Figure 9. Regression of Stage vs. Seepage Discharge from August 1994 to December 1996.

Guardo (1998) performed additional analysis for estimating seepage underneath the L-7 levee. His analysis is reported to accurately estimate seepage flow into the ENR project as a function of mean daily stages (feet) in the WCA-1 and the ENR project. Using 42 seepage measurements reported in this report from August 19, 1994 to July 16, 1996, an exponential equation was developed with a $r^2 = 0.932$.

$$\text{surficial SEEP} = 0.1446 (\text{Stg}_{\text{WCA-1}} - 15.0)^{1.3121} \times (\text{Stg}_{\text{WCA-1}} - \text{Stg}_{\text{ENR}})^{2.0246} (2)$$

Where:

surficial SEEP = surficial seepage into the ENR Project from WCA-1 (cfs)

$\text{Stg}_{\text{WCA-1}}$ = mean daily stage in WCA-1 (ft. NGVD)

Stg_{ENR} = mean daily stage in the ENR Project (ft. NGVD)

WATER QUALITY

Ground water was sampled quarterly from thirteen (13) wells from December 7, 1994 to December 4, 1997. The majority of these wells are completed below the cap rock and are 20 feet in depth. In addition, the 60-foot deep well (P14B) and the 100 foot deep well (P01B) were also sampled to compare the geochemistry of the water in the deeper flow zones. The shallower wells located on the perimeter levee (10 feet) did not yield enough water to comply with the Quality Assurance Plan for the ENR Water Quality Monitoring Program. Twenty-seven parameters were analyzed. A summary for each parameter is provided in Appendix E. Detailed interpretation of the water quality analysis is not discussed in this report. However, the water quality parameters, in general, have shown little to no significant variation during the sampling period for the same well. Some temporal differences were observed between wet and dry seasons; but, in general, the ground water quality is within the range that has been reported in county-wide studies (Miller, 1988).

Preliminary geochemical pattern analyses performed indicates the water is a calcium-carbonate type typical of fresh recharge water (Frazee, 1982). This analysis can be useful in determining sources of water and in refining estimates of seepage fluxes. Water in the 60 and 100-foot deep wells has higher specific conductivity, calcium, and hardness concentrations than the 20-foot wells, indicating a longer residence time.

CONCLUSIONS

The design and installation of the ground water monitoring well network for the ENR project has provided valuable data for the interpretation of the hydrogeologic setting and hydraulic characteristics that influence subsurface seepage. The general lithology underlying the ENR project indicates the 200-foot thick surficial aquifer can be subdivided into four units. A calcareous mud that is case hardened in most places (cap rock) separates the peat layer from sand, sandstone, limestone and shell units of the Fort Thompson and Anastasia formations. The cap rock also acts as a semi-confining unit, which impedes upward-hydraulic flow from deeper zones. It also impedes seepage flow between the Water Conservation Area 1 (WCA-1) and the ENR project. The thickness of the cap rock varies from one foot on the western perimeter to six feet along the L-7 levee.

Five ground water monitoring wells, located along the L-7 levee, ranging from a depth of -77 feet to 5.61 feet NGVD were constructed to intercept seepage flowing from WCA-1 into the ENR project and to identify zones of higher permeability. A pump test performed on the lower permeable zone in the surficial aquifer at -77 feet NGVD resulted in a transmissivity of 44.89 ft.²/min. Transmissivity of 9.37 ft.²/min was calculated in the upper zone of the surficial aquifer (-42.43 feet NGVD). Surface water levels in the WCA-1 and the ENR project indicate an average head difference of 4.68 feet.

Wells located on the perimeter levee were constructed in the core of the levee and below the semi-confining cap rock (approximately 20 feet bls). Water levels, collected below the cap rock, indicate a downward gradient with the exception of monitoring wells P04 and P07, which show slight upward movement of seepage from deeper zones. Slug tests were also performed on each well; the results are provided in Appendix D. Water levels from the ENR project and the seepage canal ranged from -2.52 feet NGVD for P07 to 5.79 feet NGVD in well P06.

The component of seepage underneath the L-7 levee, which is collected by the 21 culverts located along the toe of the 5.2-mile long L-7 levee, was measured every two weeks between August 19, 1994 to April 4, 1996 and monthly from May 15, 1996 to December 18, 1996. Discharge ranged from 0.41 to 27.70 cfs or 0.26 mgd and 17.89 mgd. The average of the sum of 47 instantaneous seepage measurements from 21 culverts was 7.44 cfs.

Ground water quality has shown little to no significant variation during the sampling period for the same well. Some differences have been observed between season's changes; but, in general, the concentration of ground water parameters is in the range that has been reported in County-wide studies. Ground water quality in deeper flow paths indicates a longer ground water residence time based on parameters such as hardness, specific conductivity and calcium.

RECOMMENDATIONS

1. Continue water level and water quality data collection to quantify the components of the ENR project water budget, particularly the seepage component that will help determine the nutrient budget and thus the efficiency of the project.
2. Develop a three-dimensional model to further refine the estimates of seepage and to evaluate the interactive impacts from surface water and the deeper permeable flow zones using the data available in this report. The model should have the capability to estimate the vertical and horizontal seepage that affects the water budget. This model should also provide an evaluation of the controlling hydraulic conditions on other variables. This information can be used by water managers to minimize the impact of seepage in the design and construction of future STAs.
3. Publish the results of 12 cross-section models that were developed during the course of this study to document the water budget and estimates of subsurface seepage into and out of the ENR project through the L-7 and perimeter levees.

REFERENCES

- Ardaman & Associates, Inc. 1994. The ENR Project, District Contract, No. C-5191, West Palm Beach, Florida.
- Bouwer, H. and R. C. Rice. 1976. A Slug Test Method for Determining Hydraulic Conductivity of Unconfined Aquifers with Completely or Partially Penetrating Wells, *Water Resources Research*, Vol. 12, No. 3, pp. 423-428.
- Burns & McDonnell. 1991. Design Memorandum Perimeter Levee System, Contract C89-0041, A.4, Technical Memorandum, South Florida Water Management District, West Palm Beach, Florida.
- Burns & McDonnell. 1991. Perimeter Levee Contract Drawings, Contract C91-2017, Everglades Nutrient Removal Project, South Florida Water Management District, West Palm Beach, Florida.
- Brown and Caldwell Design Team. 1996. Everglades Protection Project, Contract C-E201, Phase 1, STA 2 Treatment Works and WCA-2A Hydropattern Restoration. Technical Memorandum, South Florida Water Management District, West Palm Beach, Florida.
- Frazer, J. M., Jr. 1982. Geochemical Pattern Analysis: Methods of Describing the Southeastern Limestone Regional Aquifer System: In B. F., Beck (ed.), *Studies of the Hydrogeology of the Southeastern United States*. Americus, Special Publications: No. 1, Georgia Southwestern College, pp. 46-58.
- Geraghty & Miller, Inc. HydroSOLVE, Inc. 1996. *Aqtesolv For Windows User's Guide*. Reston, Virginia.
- Guardo, M. 1999. Hydrologic Balance for a Subtropical Treatment Wetland Constructed for Nutrient Removal, *Ecological Engineering Journal*. In Press.
- Jammal and Associates, Inc. 1983. Geotechnical Services, SFWMD Everglades Nutrient Removal Project, West Palm Beach, Florida.
- Lin, S., and L. Gregg. 1983. Water Budget Analysis Water Conservation Area 1, Technical Memorandum, South Florida Water Management District, West Palm Beach, Florida.
- Miller, W. L. 1988. Description and Evaluation of the Effects of Urban and Agricultural Development on the Surficial Aquifer System, Palm Beach County, Florida. U.S. Geological Survey, Washington, D. C., WRI 88-4056.
- Rohrer, K. P. 1992. Technical Design Memorandum. Piezometer Site Location Plan for the Everglades Nutrient Removal Project. Statement of Work. Contract C-5191, South Florida Water Management District, West Palm Beach, Florida.

APPENDIX A: Hydrogeologic Cross-Sections

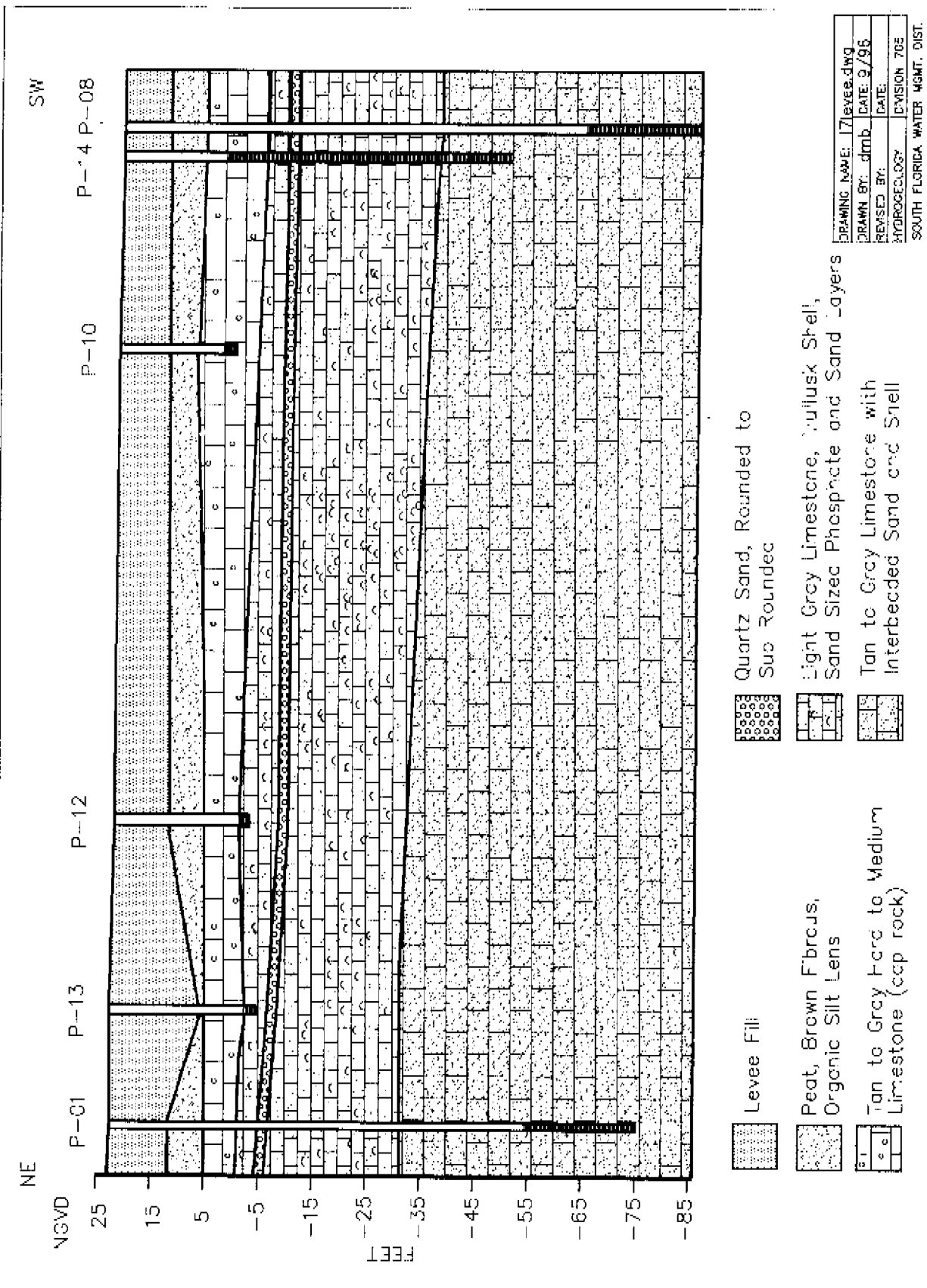

Figure A-1. Hydrogeological Cross Section of the L-7 Levee

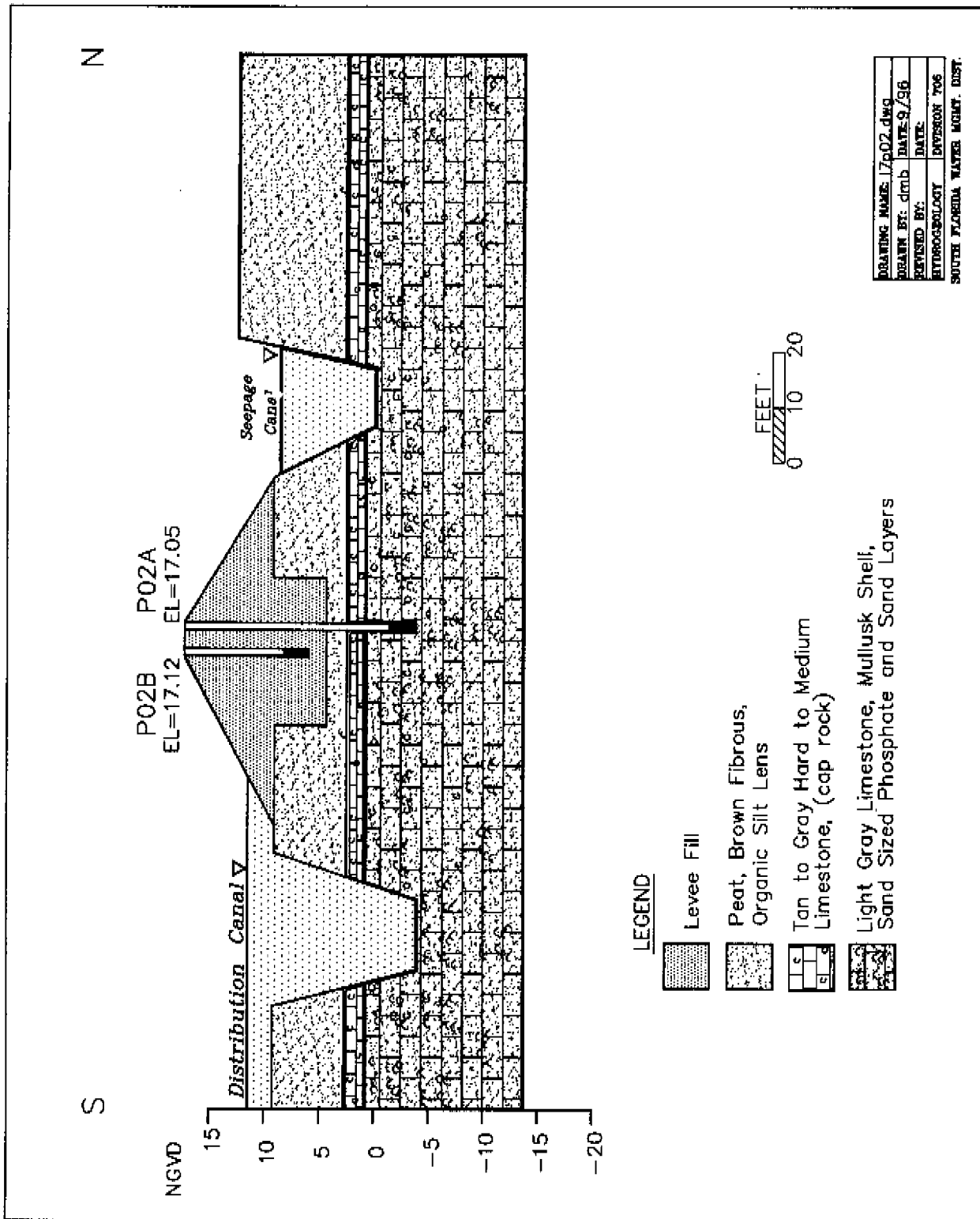

Figure A-2. Cross Section for Wells P-02A and P-02B Located on the Perimeter Levee

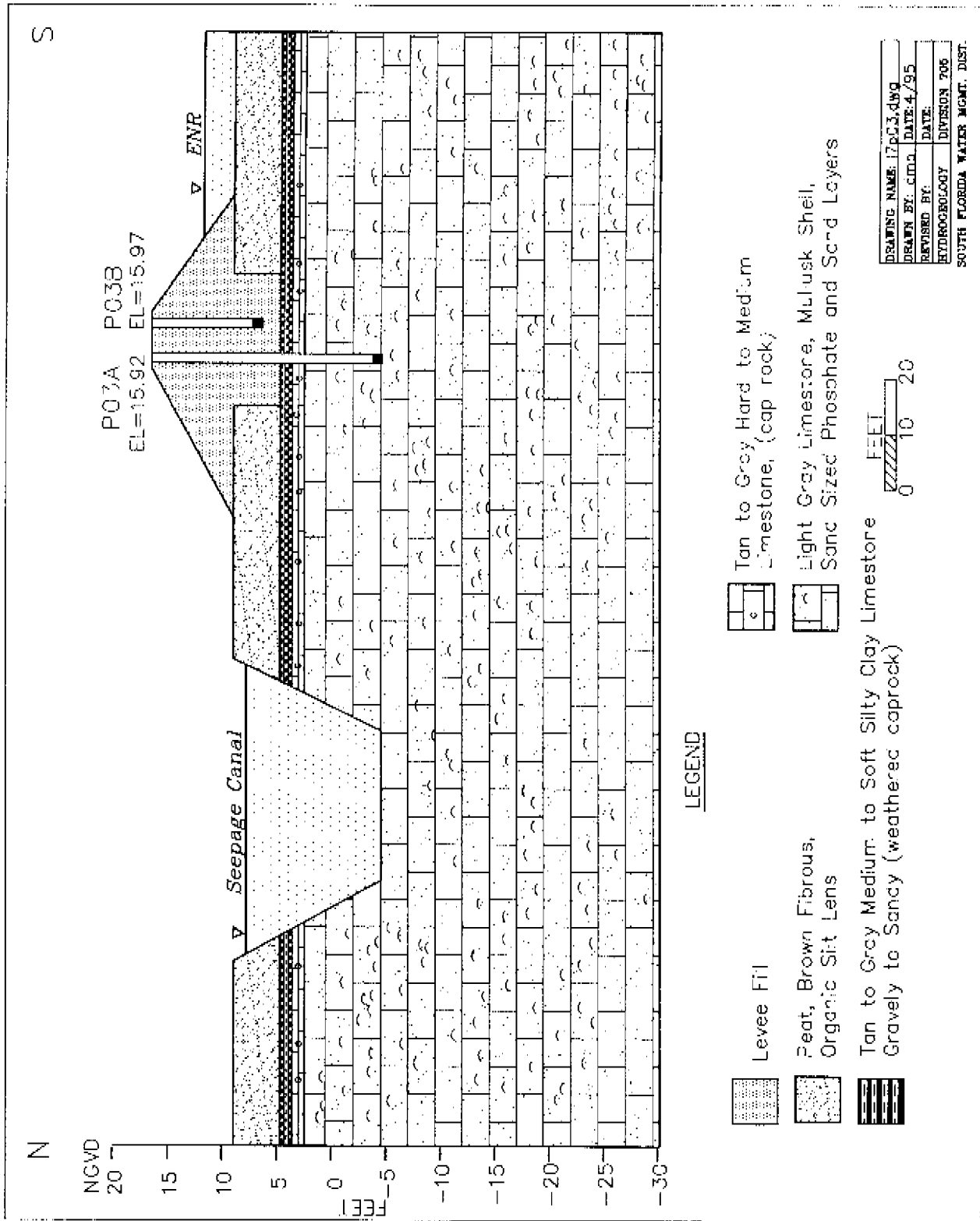

Figure A-3. Cross Section for Wells P-03A and P-03B Located on the Perimeter

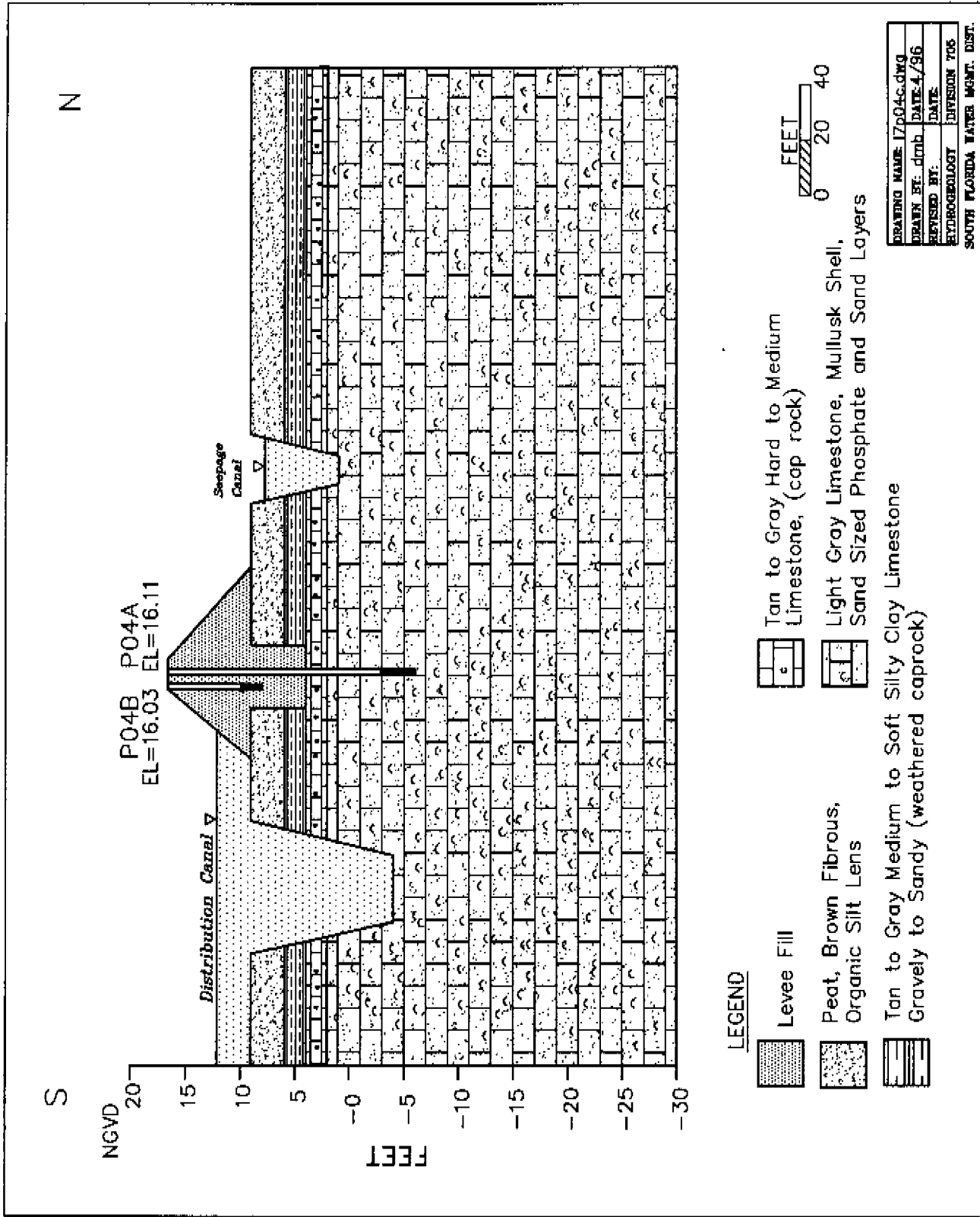

Figure A-4. Cross Section for P-04A and P-04B Located on the Perimeter Levee

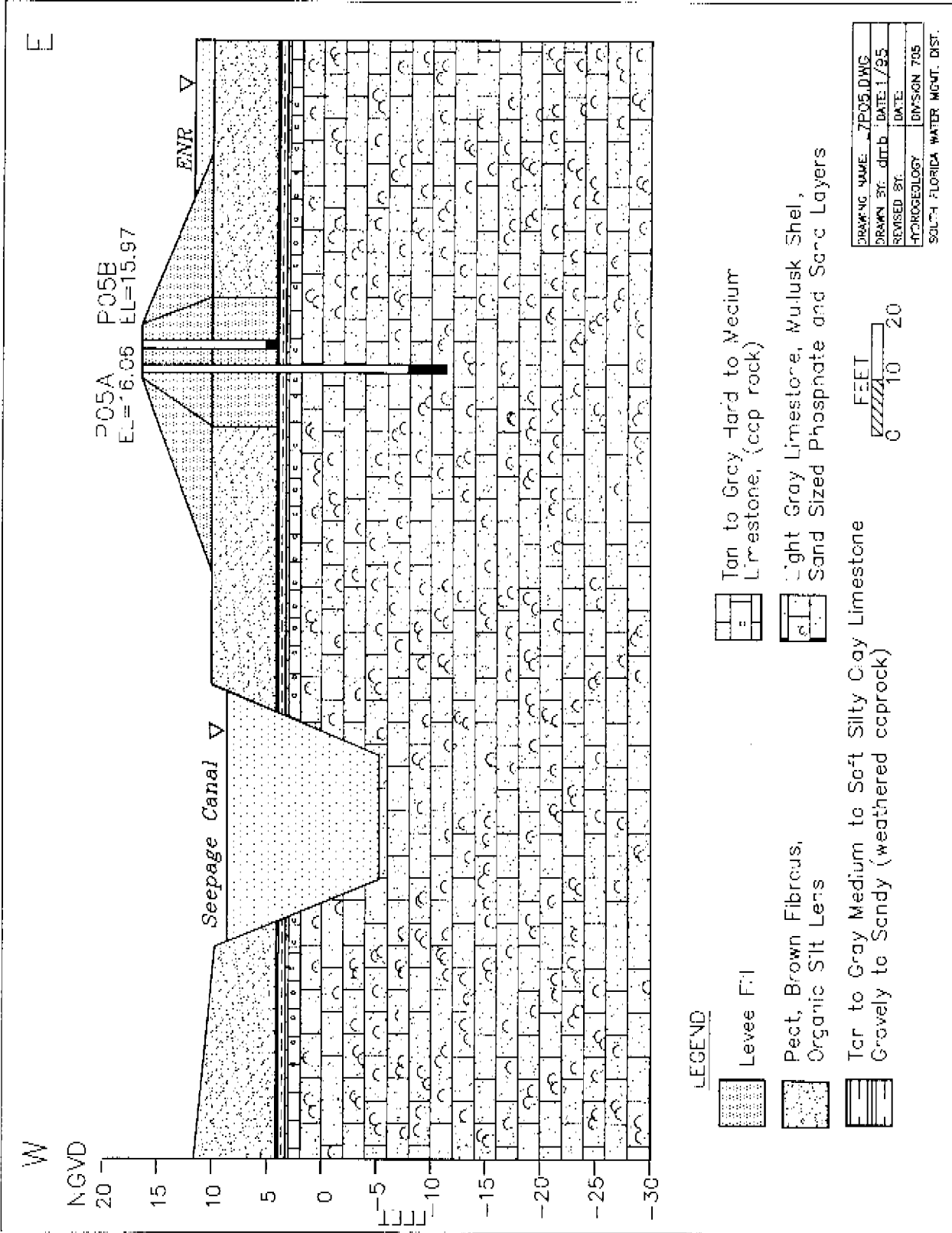

Figure A-5. Cross Section for Wells P-05A and P-05B Located on the Perimeter Levee

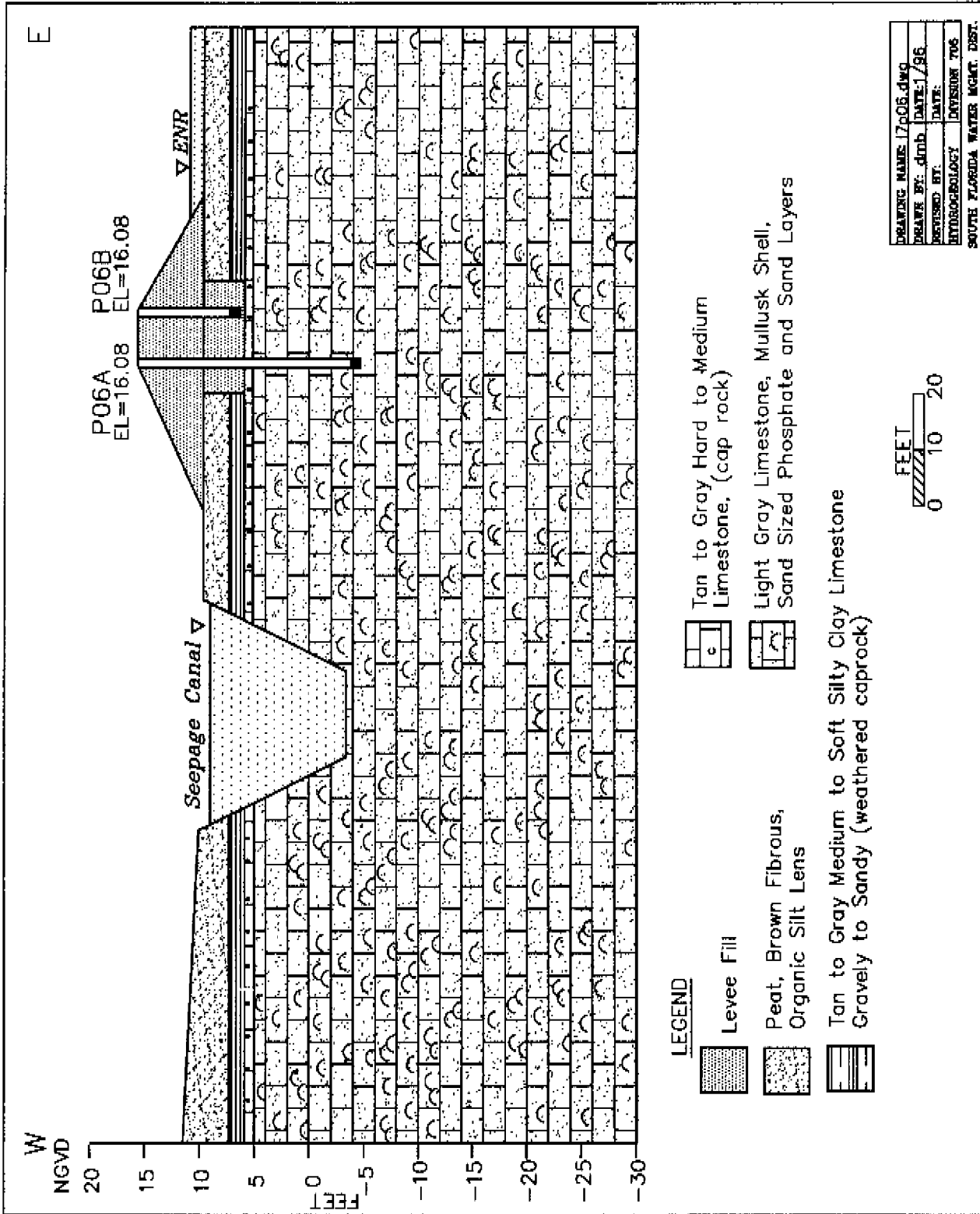

Figure A-6. Cross Section for Wells P-06A and P-06B Located on the Perimeter Levee

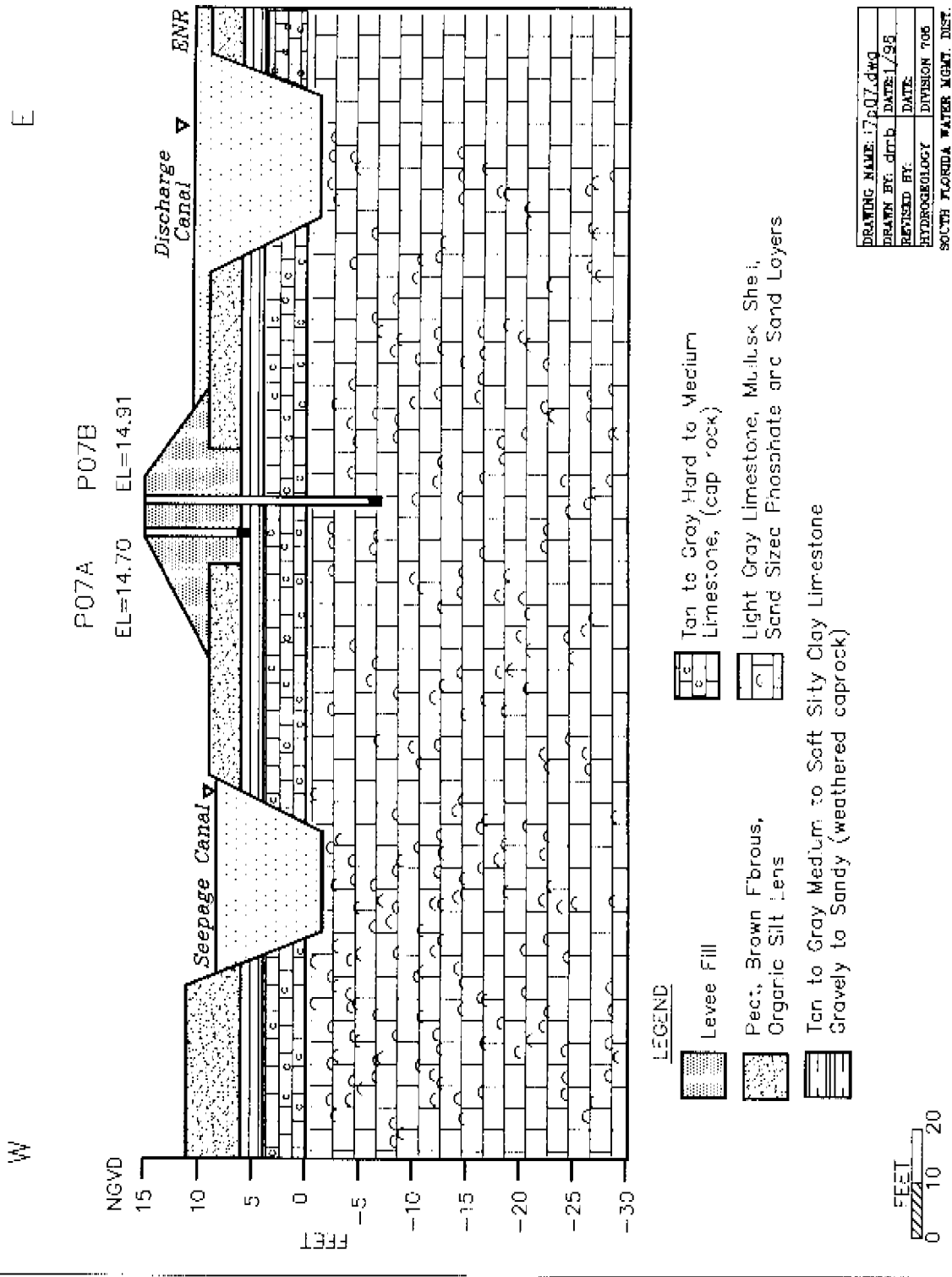

Figure A-7. Cross Section for Wells P-07A and P-07B Located on the Perimeter Levee

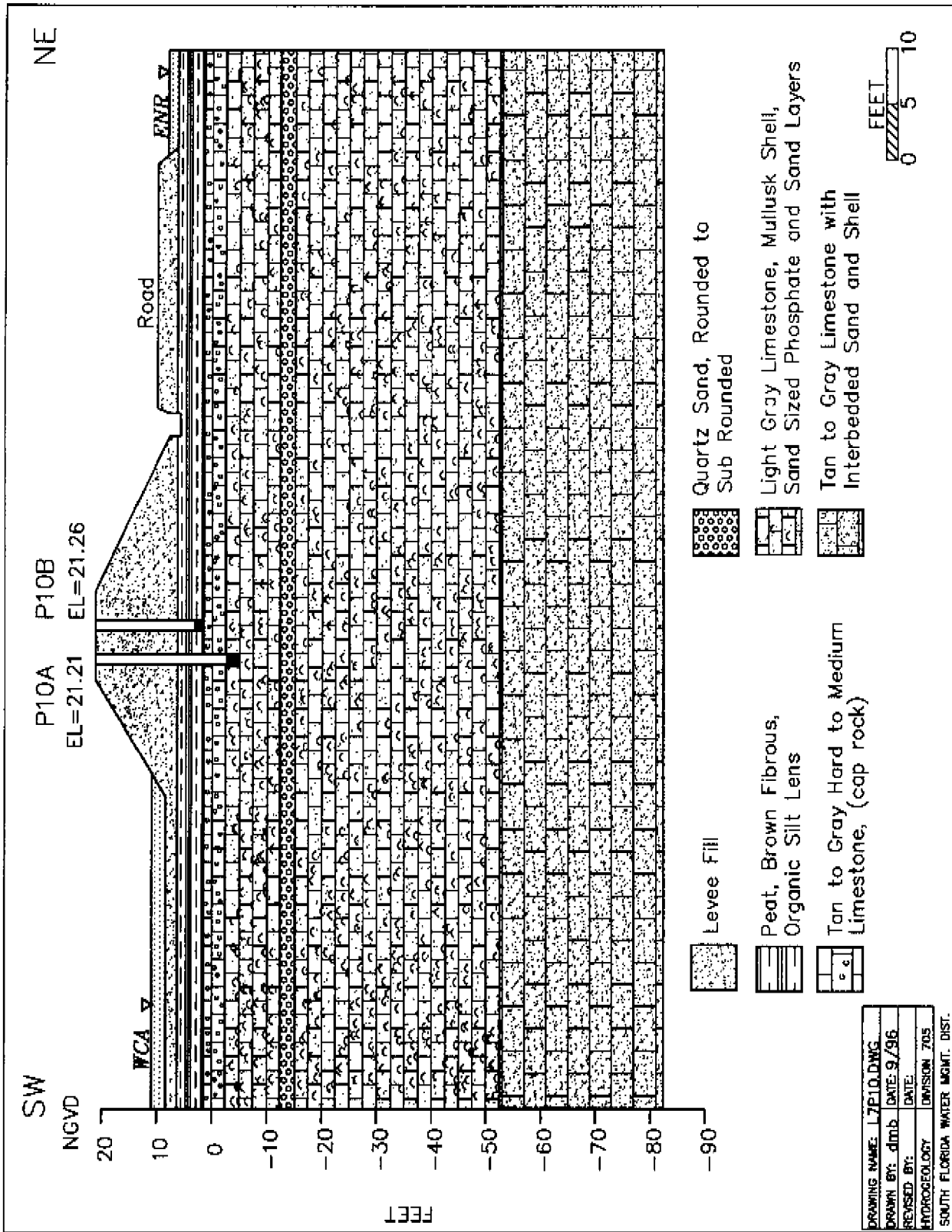

Figure A-8. Cross Section for Wells P-10A and P-10B Located on the L-7 Levee

E

W

P113 EL=14.79 P111A EL=14.84

NGVD

15

10

5

0

-5

-10

FEET

Cell 4 ▽

Cell 1 ▽

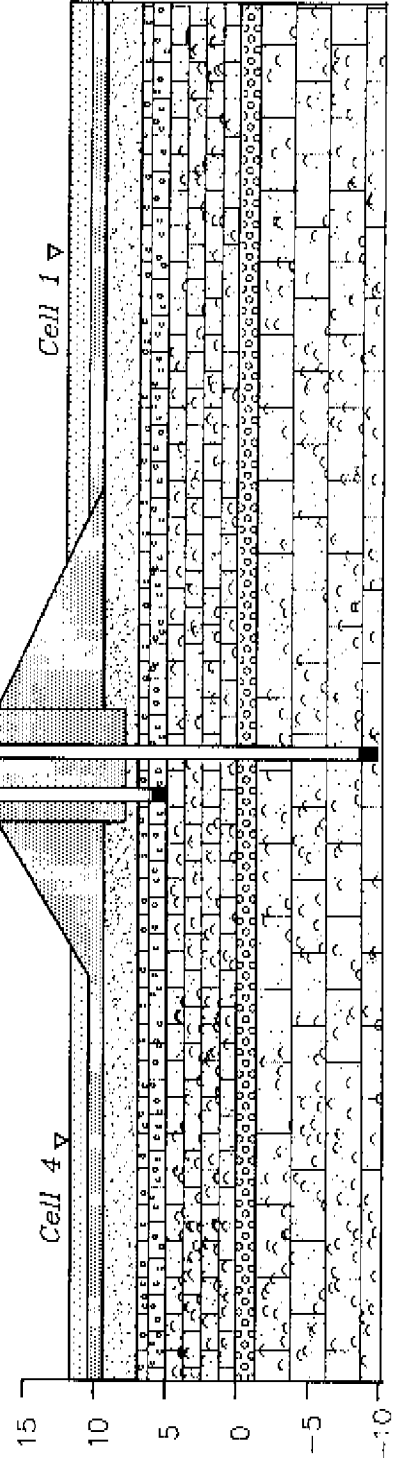

Levee Fill

Peat, Brown Fibrous, Organic Silt Lens

Tan to Gray Hard to Medium Limestone, (ccc rock)

Quartz Sand, Rounded to Sub Rounded

Light Gray Limestone, Mollusk Snell, Sand Sized Phosphate and Sand Layers

Tan to Gray Limestone with interbedded Sand and Snell



DRAWING NAME:	7P111.DWG
DRAWN BY:	dmb
DATE:	9/96
REVISION BY:	DATE:
HYDROLOGIST:	DIVISION: 705
SOUTH FLORIDA WATER MGMT. DIST.	

Figure A-9. Cross Section for Wells P-11A and P-11B Located on the L-7 Levee

SW

NE

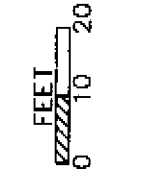
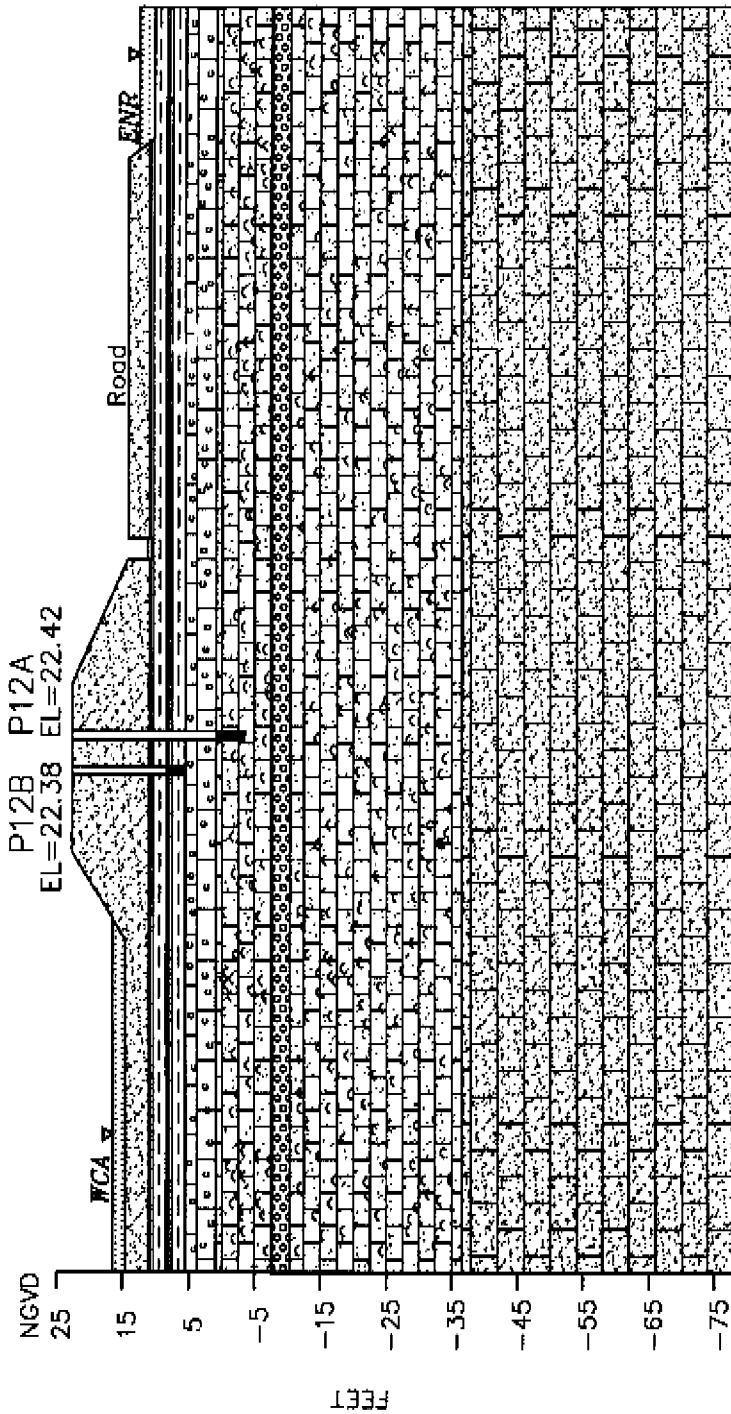

- Levee Fill
- Peat, Brown Fibrous, Organic Silt Lens
- Tan to Gray Hard to Medium Limestone, (cap rock)
- Quartz Sand, Rounded to Sub Rounded
- Light Gray Limestone, Mollusk Shell, Sand Sized Phosphate and Sand Layers
- Tan to Gray Limestone with Interbedded Sand and Shell

DRAWING NAME:	17P12.DWG
DRAWN BY:	sdh
DATE:	1/95
REVISION BY:	DATE:
HYDROGEOLOGY:	DIVISION 705
SOUTH FLORIDA WATER MGMT. DIST.	

Figure A-10. Cross Section for Wells P-12A and P-12B Located on the L-7 Levee

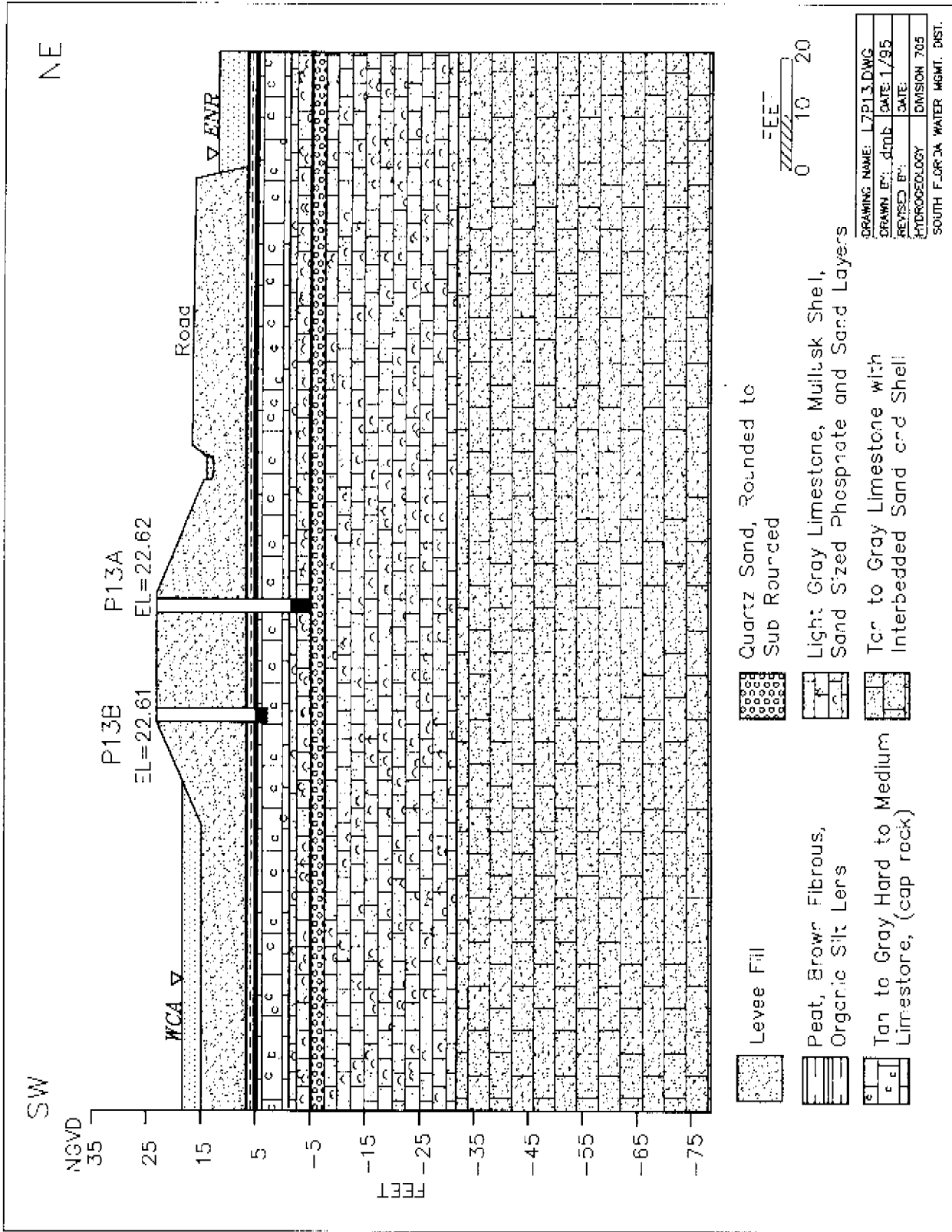

Figure A-11. Cross Section for Wells P-13A and P-13B Located on the L-7 Levee

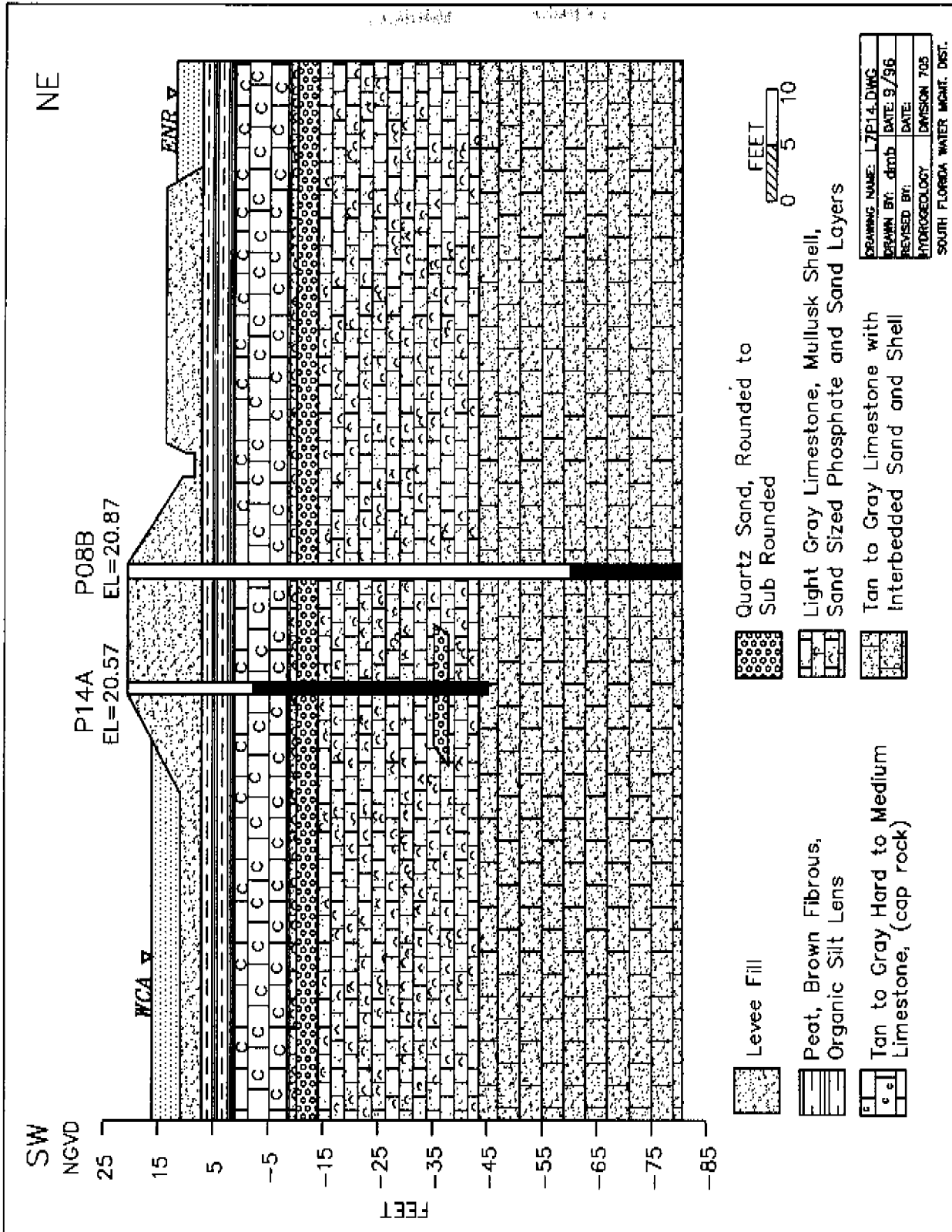

Figure A-12. Cross Section for Wells P-14A and P-08B Located on the L-7 Levee

APPENDIX B: Surface Water and Ground Water Level Graphs

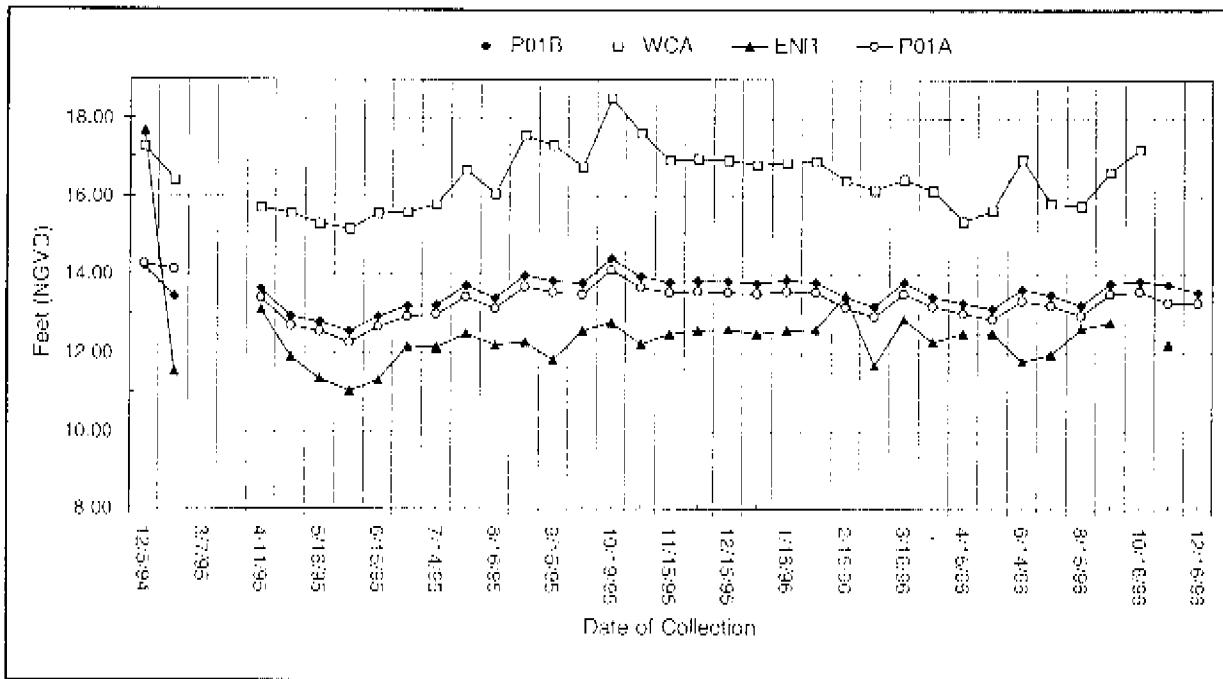

Figure B-1. Ground Water Levels for P01A and P01B vs. Surface Water Levels

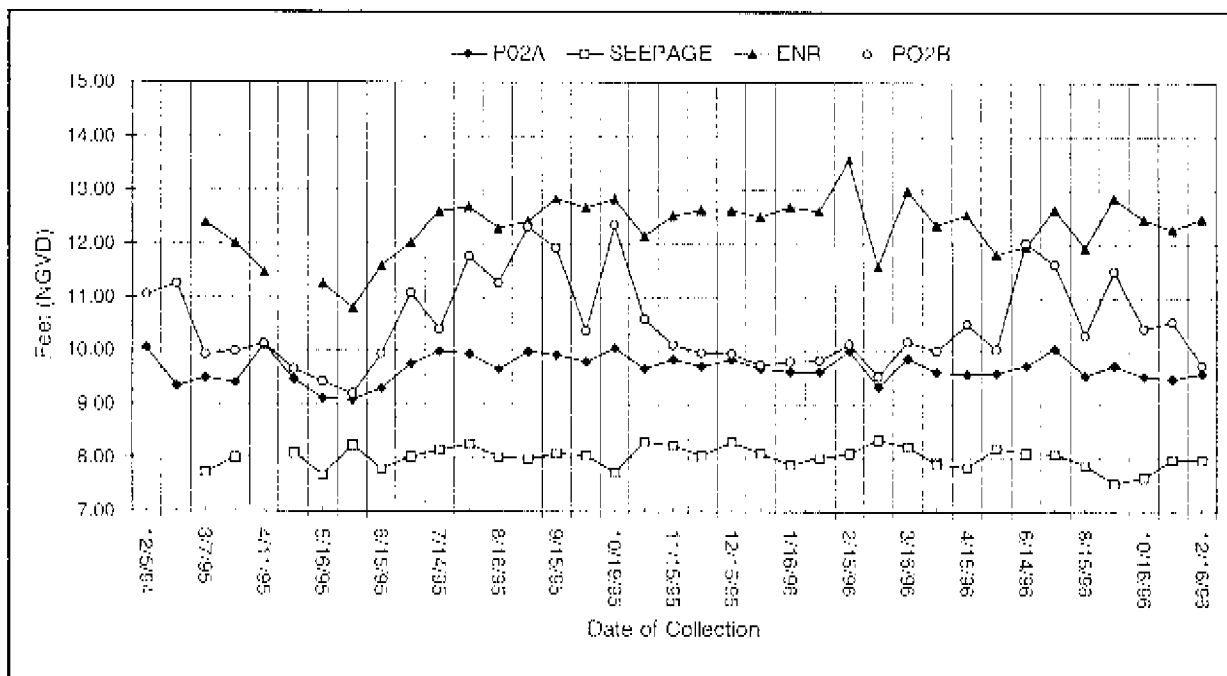

Figure B-2. Ground Water Levels for P02A and P02B vs. Surface Water Levels

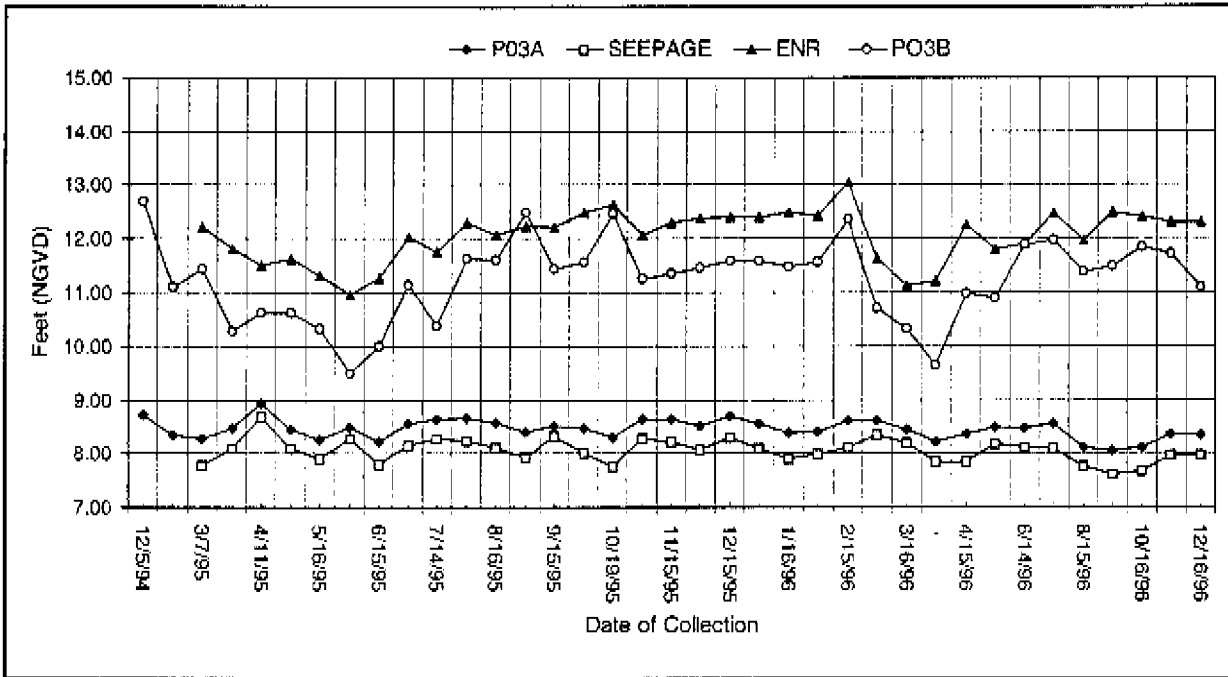

Figure B-3. Ground Water Levels for P03A & B vs. Surface Water Levels

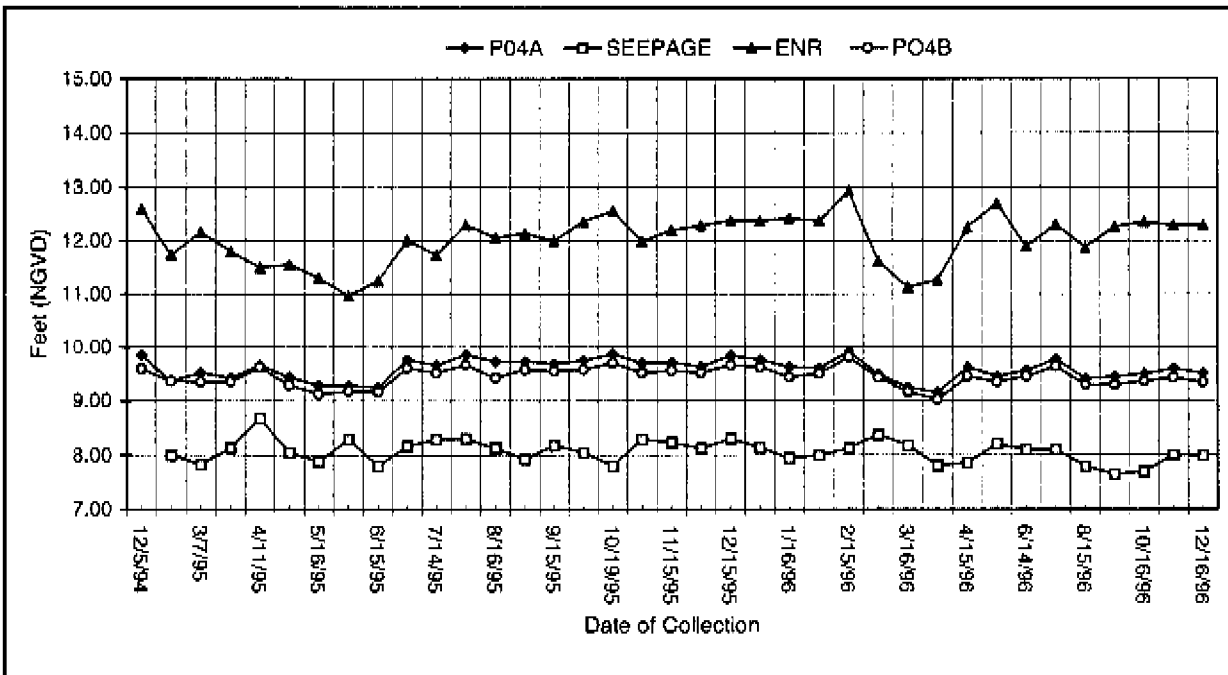

Figure B-4. Ground Water Levels for P04A & B vs. Surface Water Levels

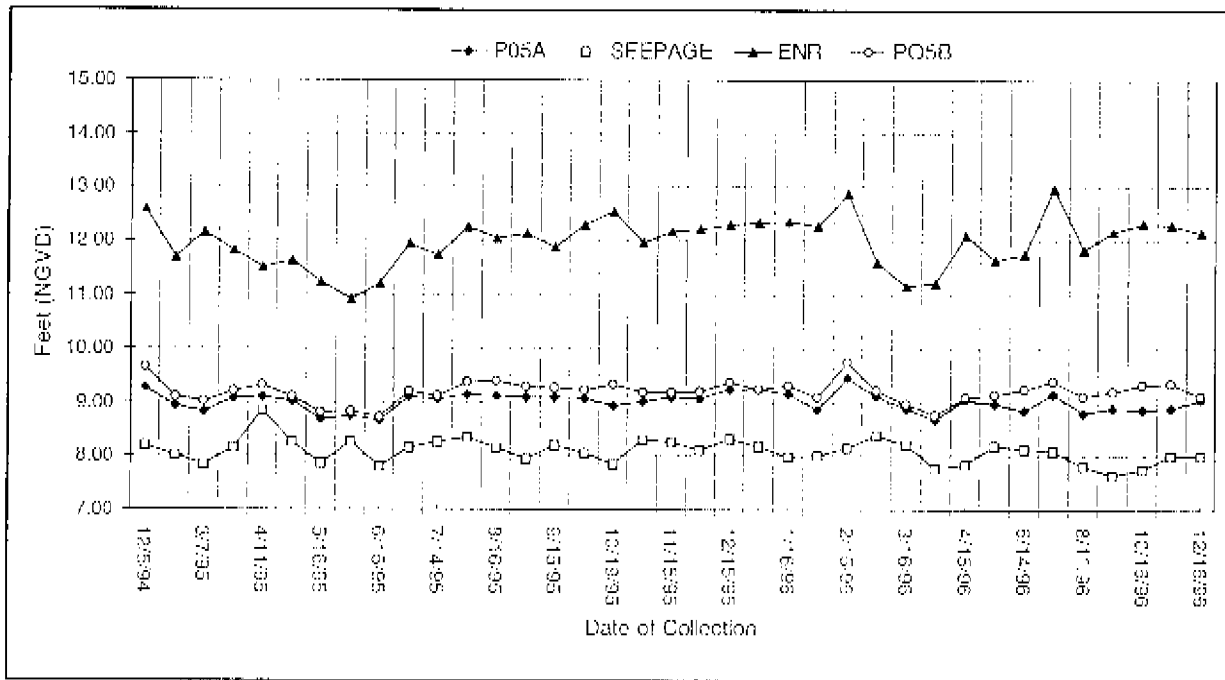

Figure B-5. Ground Water Levels for P05A & B vs. Surface Water Levels

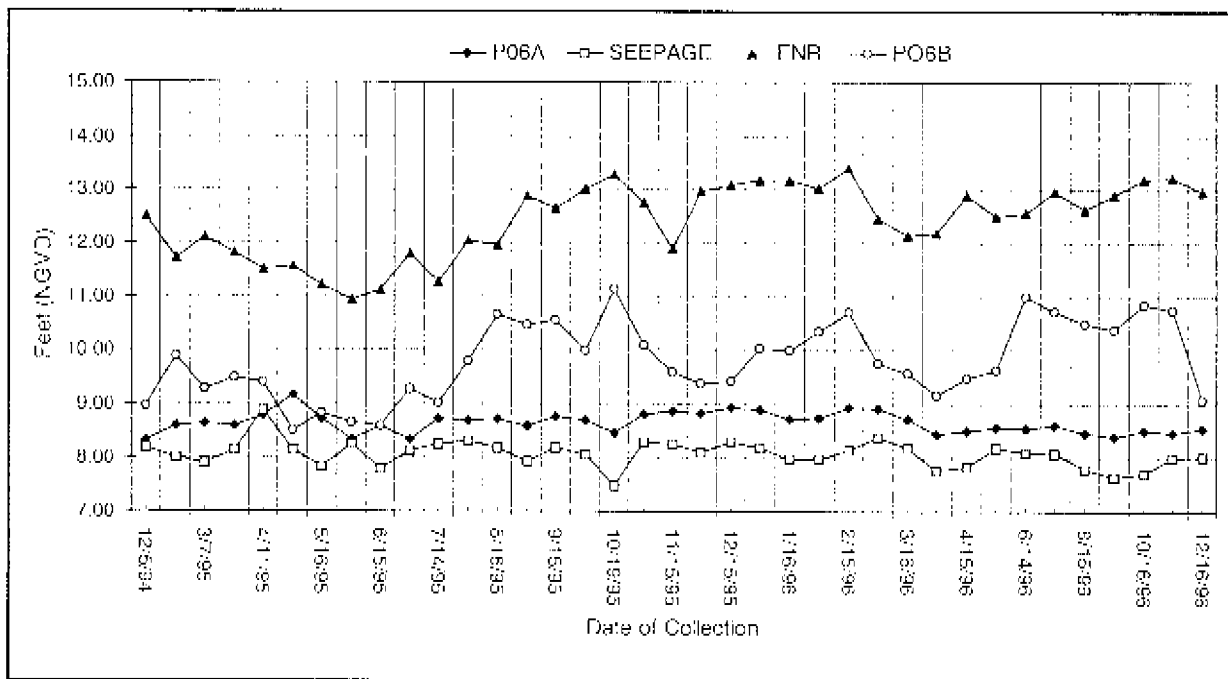

Figure B-6. Ground Water Levels for P06A & B vs. Surface Water Levels

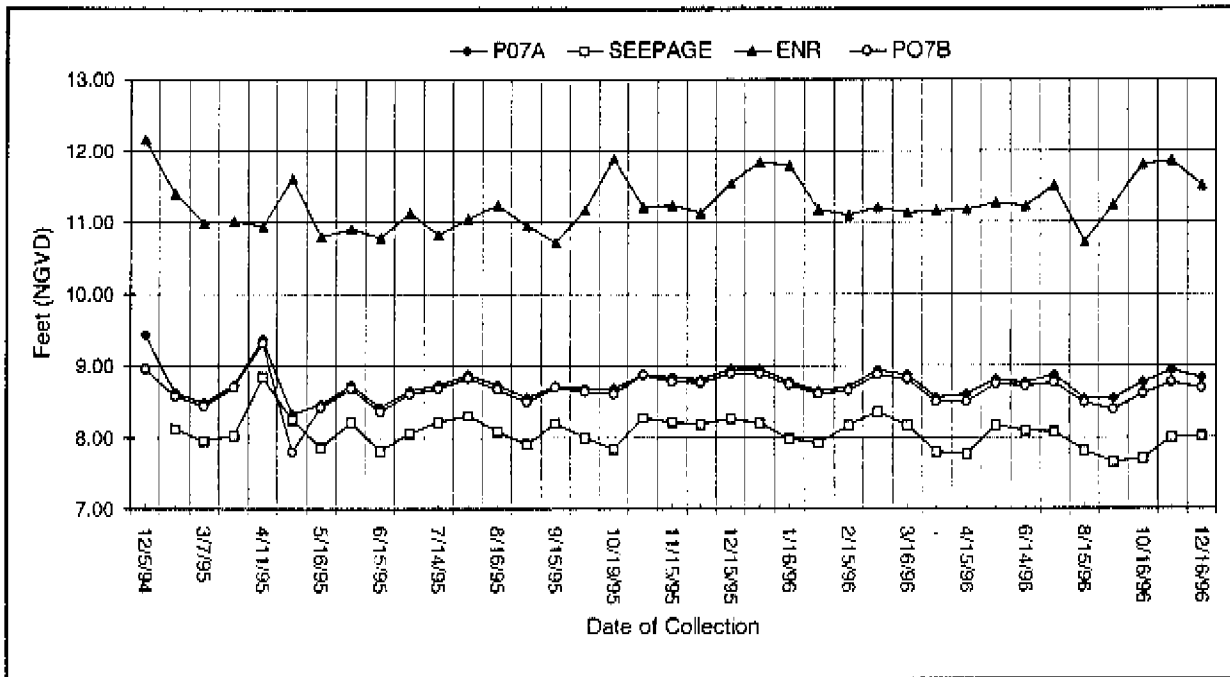

Figure B-7. Ground Water Levels for P07A & B vs. Surface Water Levels

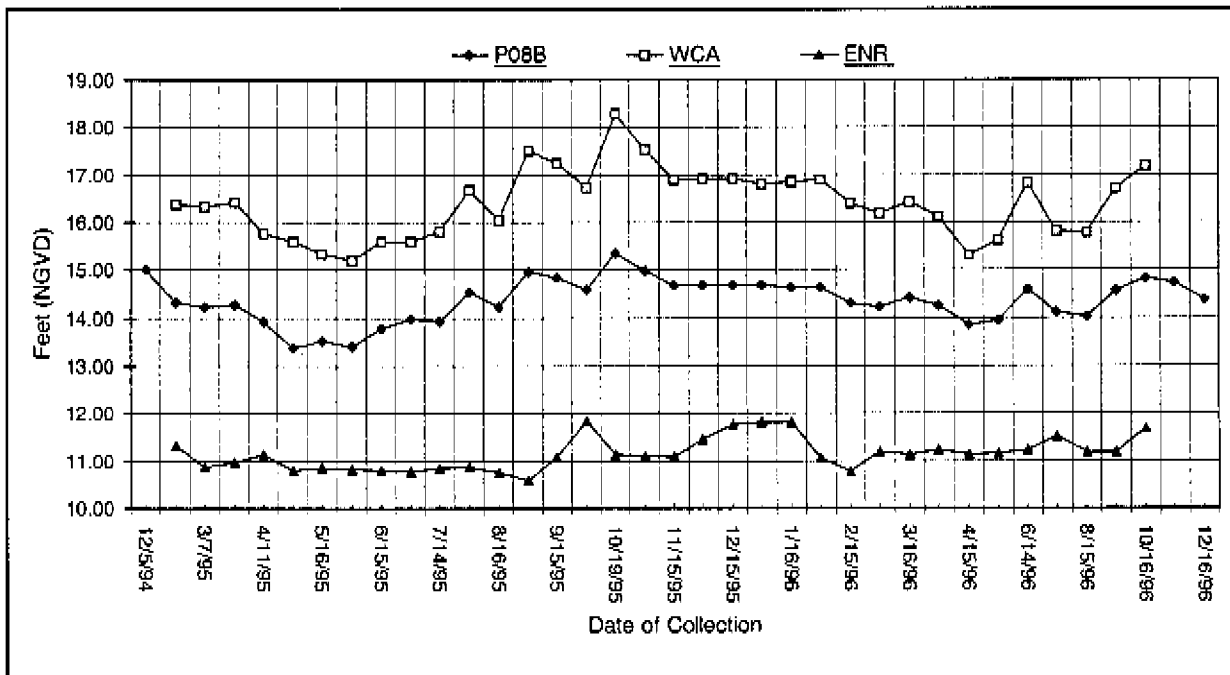

Figure B-8. Ground Water Levels for P08B vs. Surface Water Levels

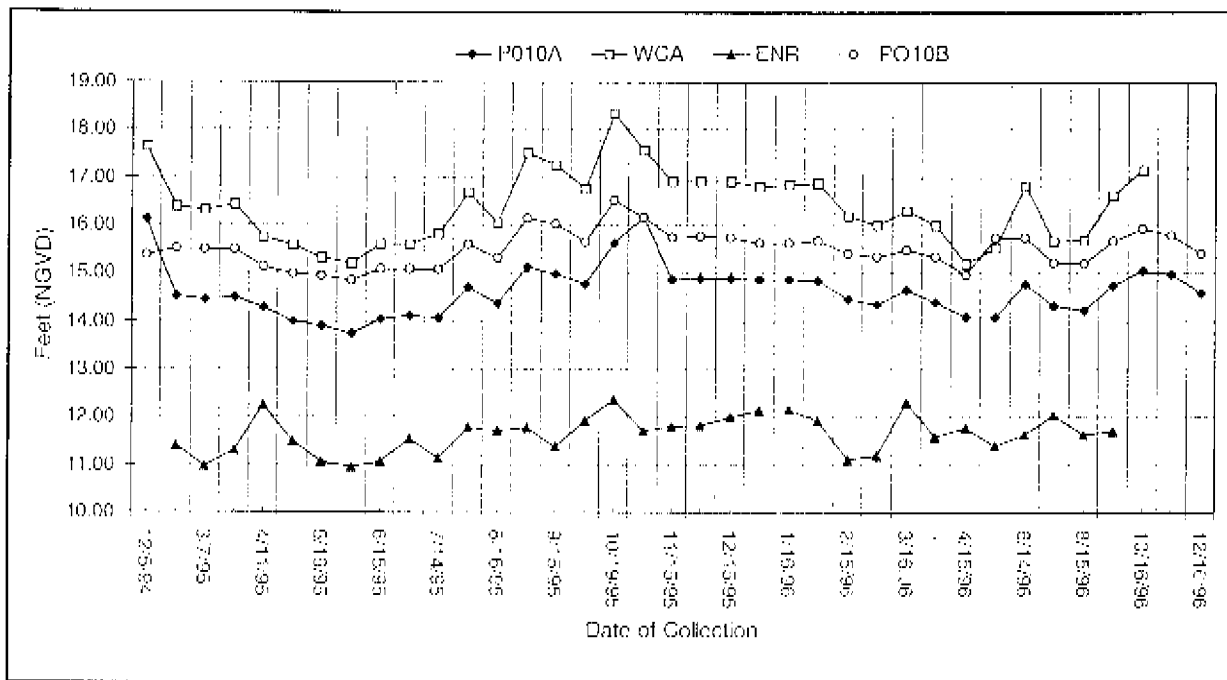

Figure B-9. Ground Water Levels for P10A & B vs. Surface Water Levels

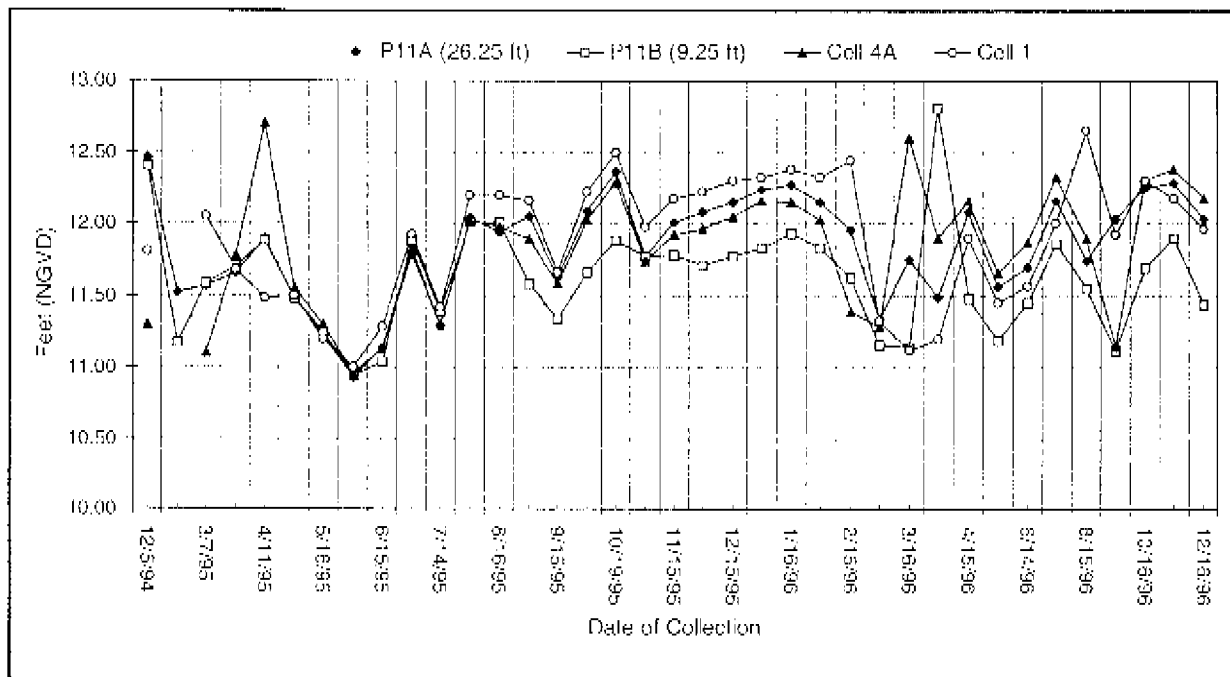

Figure B-10. Ground Water Levels for P11A & B vs. Surface Water Levels

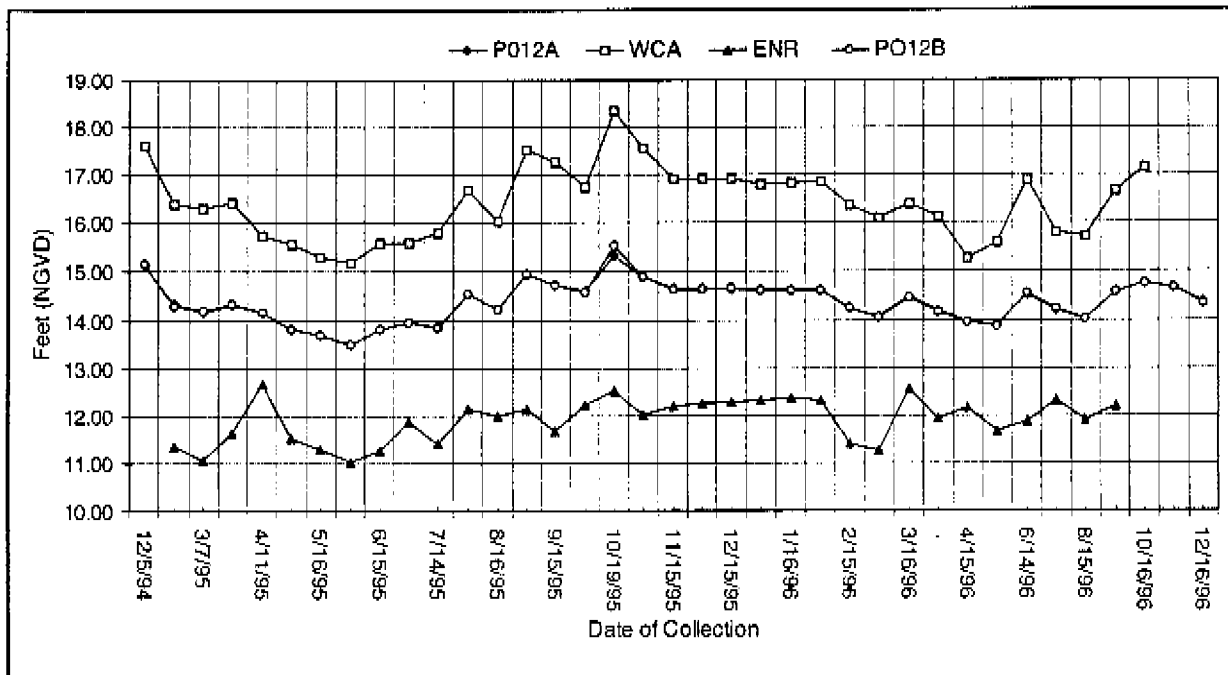

Figure B-11. Ground Water Levels for P12A & B vs. Surface Water Levels

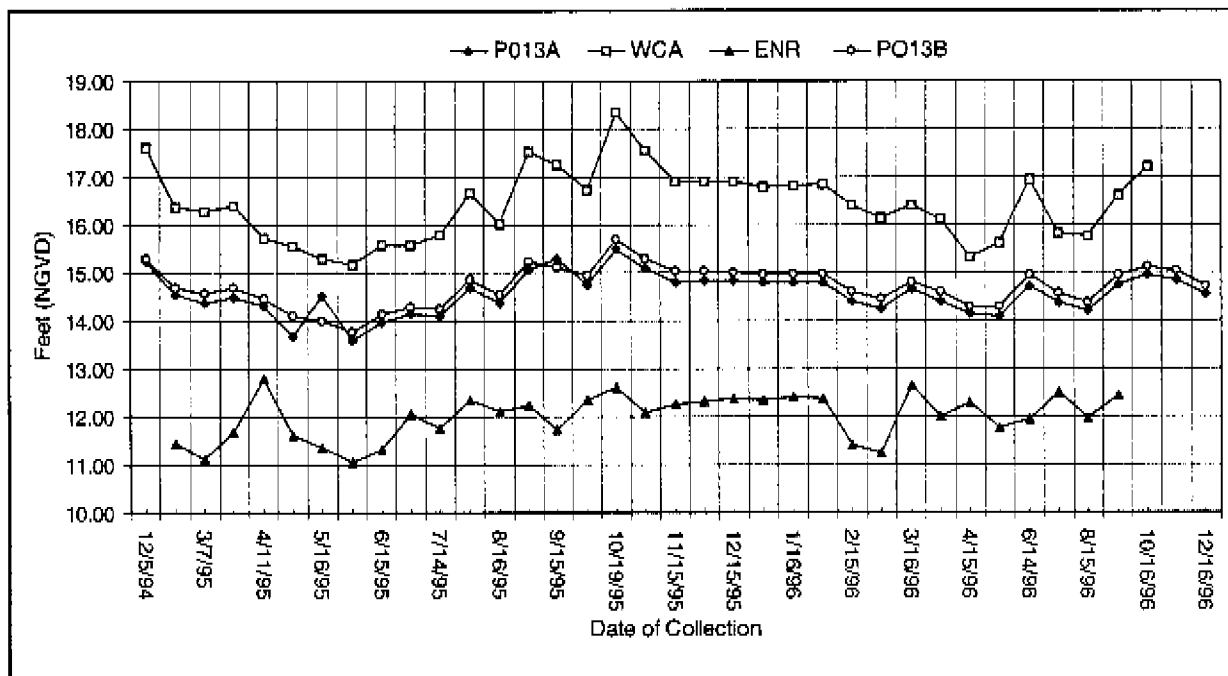

Figure B-12. Ground Water Levels for P13A & B vs. Surface Water Levels

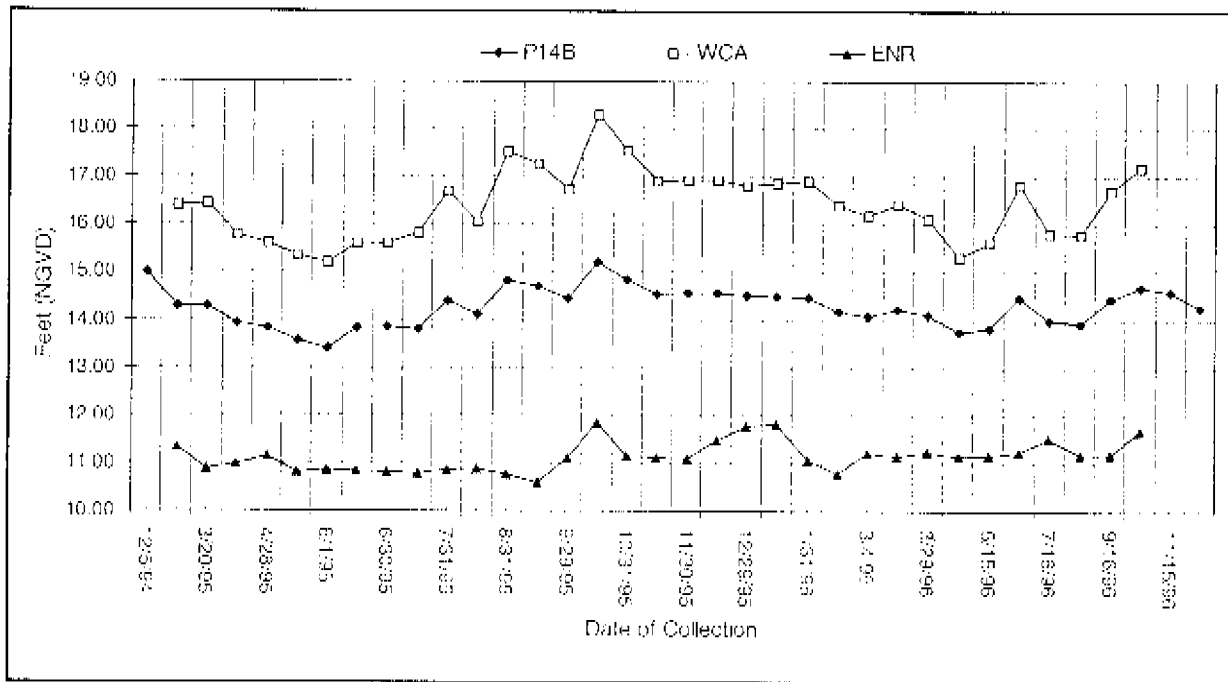

Figure B-13. Ground Water Levels for P14B vs. Surface Water Levels

APPENDIX C: Tabulated Surface Water and Ground Water Levels

Table C-1. Tabulated Surface Water and Ground Water Levels.

Well Name	Date Of Collection	Levee Well	Levee Well	Water Level Diff.	Water Level Seepage Canal (OUT)	ENR (IN)	Surface Water Diff.	WCA Stage	ENR Stage	Stage Diff.	Piezometers		Piezometer Difference
											Adjacent To Levee Wells (WCA) Out	(ENR) In	
P01		P01A	P01B					ENR003	252 IU				
	2/25/94	14.26	14.2	0.05				17.27	17.67	-0.40	18.17	18.46	-0.29
	2/25/95	14.13	13.44	0.69				16.41	17.52	4.89			
	3/7/95												
	3/20/95												
	4/1/95	13.40	13.64	-0.24				15.70	13.12	2.58	15.66	13.74	1.92
	4/28/95	12.71	12.94	-0.23				15.53	11.51	3.55	15.66	13.66	2.00
	5/7/95	12.56	12.80	-0.24				15.30	11.35	3.55	15.3	13.22	2.09
	6/1/95	12.28	12.55	-0.27				15.17	11.04	4.13	15.14	13.22	1.92
	6/7/96	12.67	12.93	-0.26				15.67	11.32	4.25	15.54	13.95	1.59
	6/30/96	12.95	13.21	-0.26				15.58	12.18	3.40	15.6	14.07	1.44
	7/14/96	12.99	13.24	-0.25				15.80	12.17	3.63	15.56	13.69	1.86
	7/3/96	13.44	13.72	-0.28				16.67	12.49	4.18	16.66	14.14	2.52
	8/16/96	13.13	13.40	-0.27				16.06	12.22	3.84	16.02	14.12	1.90
	8/3/96	13.69	13.87	-0.28				17.57	12.31	5.26	17.56	14.17	3.38
	9/15/96	13.53	13.82	-0.29				17.3	11.83	5.48	17.28	14.16	3.12
	9/29/96	13.50	13.76	-0.26				16.75	12.58	4.17	16.76	14.13	2.63
	10/19/96	14.12	14.41	-0.29				18.52	12.79	5.73	18.47	14.29	4.18
	10/31/96	13.67	13.94	-0.27				17.60	12.23	5.37	17.27	14.29	2.98
	11/15/96	13.55	13.81	-0.26				16.93	12.51	4.42	16.83	14.42	2.41
	11/30/96	13.50	13.84	-0.28				16.95	12.58	4.37	16.90	14.32	2.58
	12/13/96	13.55	13.92	-0.27				16.97	12.62	4.23	16.82	14.27	2.55
	12/29/96	13.51	13.78	-0.27				16.82	12.50	4.32	16.87	14.32	2.55
	1/16/96	13.57	13.85	-0.28				16.86	12.58	4.28	16.90	14.15	2.75
	1/31/96	13.55	13.81	-0.26				16.88	12.61	4.27	16.92	14.14	2.78
	2/15/96	13.16	13.44	-0.28				16.41	13.50	2.91	16.38	14.15	2.23
	3/4/96	12.93	13.19	-0.26				16.17	11.70	4.47	16.13	14.06	2.07
	3/16/96	13.51	13.80	-0.29				16.42	12.87	3.55	16.42	14.11	2.31
	3/29/96	13.19	13.44	-0.25				16.14	12.31	3.83	16.12	14.00	2.12
	4/15/96	13.03	13.27	-0.24				15.36	12.54	2.8	15.30	13.86	1.44
	5/15/96	12.88	13.14	-0.26				15.64	12.52	3.12	15.59	13.46	2.13

Table C-1. Tabulated Surface Water and Ground Water Levels.

Well Name	Date Of Collection	Levee Well	Levee Well	Water Level Diff.	Water Level Seepage Canal (OUT)	ENR (IN)	Surface Water Diff.	WCA Stage	ENR Stage	Stage Diff.	Piezometers Adjacent To Levee Wells (WCA) Out	(ENR) In	Piezometer Difference
	6/14/96	13.35	13.64	-0.29				16.95	11.82	5.13	16.95	13.70	3.25
	7/16/96	13.24	13.50	-0.26				15.83	11.97	3.86	15.76	14.22	1.54
	8/15/96	12.97	13.23	-0.26				15.78	12.66	3.12	15.76	13.47	2.29
	9/16/96	13.52	13.78	-0.26				16.63	12.80	3.83	16.69	14.10	2.59
	10/18/96	13.57	13.82	-0.25				17.20	N	17.20	17.18	14.29	2.89
	11/15/96	13.29	13.75	-0.46				N	12.24		16.97	14.25	2.72
	12/16/96	13.29	13.54	-0.25							16.49	14.28	2.21
	1/16/97	13.10	13.35	-0.25							18.17	18.46	-0.29
	2/13/97	12.92	13.17	-0.25							16.27	14.11	2.16
	3/17/97	12.06	13.31	-1.25							15.99	14.23	1.76
	4/14/97	13.04	13.30	-0.26							15.55	13.73	1.82
	5/14/97	12.99	13.25	-0.26							16.76	14.26	2.50
	6/16/97	13.27	13.54	-0.27							16.28	14.21	2.07
	7/16/97	13.20	13.46	-0.26							16.88	14.27	2.61
	8/19/97	13.31	13.61	-0.30							16.82	14.32	2.50
	9/15/97	13.13	13.43	-0.30							17.04	14.26	2.78
	10/15/97	12.99	13.29	-0.30							17.09	14.20	2.89
	11/17/97	13.01	13.33	-0.32									
	12/15/97	13.62	13.89	-0.27									
P02													
		P02A	P02B										
	12/5/94	10.04	11.03	-0.99									
	1/25/94	9.33	11.24	-1.91									
	3/7/95	9.47	9.91	-0.44	7.74	12.40	-4.66						
	3/20/95	9.39	9.99	-0.60	8.00	12.00	-4.00						
	4/11/95	10.10	10.12	-0.02		11.48							
	4/28/95	9.45	9.65	-0.20	8.09								
	5/16/95	9.10	9.41	-0.31	7.69	11.25	-3.56						
	6/1/95	9.08	9.19	-0.11	8.23	10.80	-2.57						
	8/30/95	9.75	11.08	-1.33	8.03	12.02	-3.99						
	7/14/95	9.98	10.41	-0.43	8.16	12.60	-4.44						

Table C-1. Tabulated Surface Water and Ground Water Levels.

Well Name	Date of Collection	Levee Well	Levee Well	Water Level Diff.	Water Level Seepage Canal (OUT)	ENR (IN)	Surface Water Diff.	WCA Stage	ENR Stage	Stage Diff.	Piezometers Adjacent To Levee Wells (WCA) Out	(ENR) In	Piezometer Difference
	7/31/95	9.95	11.77	-1.82	8.26	12.70	-4.44						
	8/7/95	9.65	11.26	-1.61	8.03	12.35	-4.27						
	8/31/95	9.99	12.31	-2.32	7.98	12.42	-4.44						
	9/15/95	9.91	11.92	-2.01	8.10	12.84	-4.74						
	9/29/95	9.79	10.96	-0.57	8.04	12.66	-4.62						
	10/19/95	10.04	12.36	-2.32	7.74	12.84	-5.10						
	10/31/95	9.86	10.60	-0.94	8.30	12.15	-3.85						
	11/15/95	9.94	10.11	-0.27	8.24	12.62	-4.28						
	11/30/95	9.71	9.97	-0.26	8.04	12.62	-4.56						
	12/15/95	9.84	9.90	-0.09	8.30	12.62	-4.32						
	12/29/95	9.67	9.74	-0.07	8.09	12.50	-4.41						
	1/16/96	9.81	9.80	-0.19	7.88	12.70	-4.82						
	1/31/96	9.60	9.82	-0.22	8.00	12.61	-4.61						
	2/15/96	10.01	10.12	-0.11	8.09	12.57	-5.48						
	3/2/96	9.33	9.51	-0.18	8.34	11.58	-3.24						
	3/16/96	9.66	10.17	-0.51	8.21	12.96	-4.77						
	3/29/96	9.81	10.00	-0.39	7.90	12.35	-4.45						
	4/15/96	9.57	10.51	-0.94	7.85	12.55	-4.70						
	5/15/96	9.58	10.02	-0.44	8.19	11.80	-3.61						
	6/14/96	9.74	12.01	-2.27	8.12	11.95	-3.83						
	7/16/96	10.04	11.61	-1.57	8.10	12.65	-4.55						
	8/15/96	9.55	10.29	-0.74	7.89	11.90	-4.01						
	9/16/96	9.72	11.49	-1.77	7.56	12.85	-5.30						
	10/13/96	9.61	10.42	-0.91	7.65	12.45	-4.80						
	11/15/96	9.47	10.55	-1.08	7.96	12.26	-4.28						
	12/16/96	9.68	9.72	-0.14	7.96	12.48	-4.50						
	1/15/97	9.12	9.29	-0.17	7.57	11.65	-4.08						
	2/13/97	9.13	9.25	-0.12	7.57	11.42	-3.75						
	3/17/97	9.24	9.25	-0.01	7.52	11.94	-4.42						
	4/14/97	9.59	9.34	0.25	7.76	12.26	-4.48						
	5/14/97	9.64	9.71	0.13	8.00	12.48	-4.48						

Table C-1. Tabulated Surface Water and Ground Water Levels.

Well Name	Date Of Collection	Levee Well	Levee Well	Water Level Diff.	Water Level Seepage Canal (OUT)	ENR (IN)	Surface Water Diff.	WCA Stage	ENR Stage	Stage Diff.	Piezometers Adjacent To Levee Wells (WCA) Out	(ENR) In	Piezometer Difference
	6/16/97	9.80	10.83	-1.03	7.90	11.91	-4.01						
	7/16/97	9.90	8.89	1.01	7.91	12.23	-4.32						
	8/19/97	10.00	11.98	-1.98	7.96	11.98	-4.02						
	9/15/97	9.87	10.81	-0.94	7.62	12.64	-5.02						
	10/15/97	9.45	10.20	-0.75	7.78	12.34	-4.56						
	11/17/97	9.70	9.88	-0.18	7.60	12.43	-4.83						
	12/15/97	10.14	11.89	-1.75	7.78	12.83	-5.05						
P03		P03A	P03B		Seepage	ENR							
	12/5/94	8.73	12.68	-3.95									
	1/25/95	8.35	11.09	-2.74									
	3/7/95	8.28	11.42	-3.14	7.77	12.20	-4.43						
	3/20/95	8.47	10.28	-1.81	8.09	11.81	-3.72						
	4/11/95	8.93	10.61	-1.68	8.68	11.50	-2.82						
	4/28/95	8.44	10.62	-2.18	8.09	11.61	-3.52						
	5/16/95	8.27	10.32	-2.05	7.90	11.30	-3.40						
	6/1/95	8.50	9.49	-0.99	8.28	10.95	-2.67						
	6/15/95	8.21	10.01	-1.80	7.80	11.26	-3.46						
	6/30/95	8.56	11.19	-2.57	8.16	12.02	-3.86						
	7/14/95	8.64	10.39	-1.75	8.29	11.75	-3.46						
	7/31/95	8.66	11.62	-2.96	8.24	12.30	-4.06						
	8/16/95	8.58	11.59	-3.01	8.11	12.05	-3.94						
	8/31/95	8.41	12.49	-4.08	7.92	12.22	-4.30						
	9/15/95	8.52	11.42	-2.90	8.32	12.20	-3.88						
	9/29/95	8.46	11.55	-3.09	8.00	12.48	-4.48						
	10/19/95	8.31	12.46	-4.15	7.76	12.63	-4.87						
	10/31/95	8.64	11.25	-2.61	8.29	12.06	-3.77						
	11/15/95	8.64	11.34	-2.70	8.22	12.30	-4.08						
	11/30/95	8.51	11.46	-2.95	8.08	12.38	-4.30						
	12/15/95	8.71	11.58	-2.87	8.30	12.40	-4.10						
	12/29/95	8.55	11.58	-3.03	8.10	12.40	-4.30						

Table C-1. Tabulated Surface Water and Ground Water Levels.

Well Name	Date Of Collection	Levee Well	Levee Well	Water Level Diff.	Water Level Seepage Canal (OUT)	ENR (IN)	Surface Water Diff.	WCA Stage	ENR Stage	Stage Diff.	Piezometers Adjacent To Levee Wells (WCA) Out	(ENR) In	Piezometer Difference
	1/25/95	9.37	9.37	0.00	8.00	11.74	-3.74						
	3/7/95	9.52	9.35	0.17	7.83	12.16	-4.33						
	3/20/95	9.43	9.35	0.08	8.14	11.80	-3.66						
	4/11/95	9.66	9.62	0.04	8.68	11.50	-2.82						
	4/28/95	9.44	9.29	0.15	8.05	11.56	-3.51						
	5/16/95	9.29	9.13	0.16	7.88	11.30	-3.42						
	6/1/95	9.29	9.18	0.11	8.29	10.97	-2.68						
	6/15/95	9.25	9.17	0.08	7.80	11.25	-3.45						
	6/30/95	9.76	9.61	0.15	8.16	12.01	-3.85						
	7/14/95	9.66	9.52	0.14	8.29	11.73	-3.44						
	7/31/95	9.86	9.67	0.19	8.30	12.30	-4.00						
	8/16/95	9.73	9.43	0.30	8.13	12.06	-3.93						
	8/31/95	9.73	9.58	0.15	7.93	12.14	-4.21						
	9/15/95	9.69	9.55	0.14	8.18	12.00	-3.82						
	9/29/95	9.75	9.58	0.17	8.05	12.36	-4.31						
	10/19/95	9.87	9.70	0.17	7.80	12.56	-4.76						
	10/31/95	9.70	9.52	0.18	8.29	11.99	-3.70						
	11/15/95	9.71	9.56	0.15	8.23	12.20	-3.97						
	11/30/95	9.63	9.52	0.11	8.12	12.28	-4.16						
	12/15/95	9.84	9.66	0.18	8.30	12.38	-4.08						
	12/29/95	9.76	9.62	0.14	8.14	12.36	-4.22						
	1/16/96	9.62	9.44	0.18	7.94	12.42	-4.48						
	1/31/96	9.61	9.51	0.10	8.00	12.36	-4.36						
	2/15/96	9.92	9.81	0.11	8.13	12.93	-4.80						
	3/4/96	9.49	9.43	0.06	8.37	11.62	-3.25						
	3/16/96	9.25	9.16	0.09	8.18	11.13	-2.95						
	3/29/96	9.15	9.02	0.13	7.80	11.27	-3.47						
	4/15/96	9.62	9.45	0.17	7.86	12.25	-4.39						
	5/15/96	9.45	9.35	0.10	8.20	12.70	-4.50						
	6/14/96	9.56	9.45	0.11	8.10	11.69	-3.79						
	7/16/96	9.77	9.64	0.13	8.10	12.30	-4.20						

Table C-1. Tabulated Surface Water and Ground Water Levels.

Well Name	Date Of Collection	Levee Well	Levee Well	Water Level Diff.	Water Level Seepage Canal (OUT)	ENR (IN)	Surface Water Diff.	WCA Stage	ENR Stage	Stage Diff.	Piezometers Adjacent To Levee Walls (WCA) Out	(ENR) In	Piezometer Difference
	7/31/95	9.15	9.37	-0.22	8.35	12.24	-3.89						
	8/16/95	9.12	9.39	-0.27	8.16	12.04	-3.88						
	8/31/95	9.10	9.28	-0.18	7.95	12.12	-4.17						
	9/15/95	9.11	9.27	-0.16	8.20	11.88	-3.68						
	9/29/95	9.08	9.23	-0.15	8.05	12.29	-4.24						
	10/19/95	8.94	9.34	-0.40	7.84	12.54	-4.70						
	10/31/95	9.01	9.19	-0.18	8.30	11.96	-3.66						
	11/15/95	9.10	9.18	-0.08	8.25	12.16	-3.91						
	11/30/95	9.07	9.21	-0.14	8.11	12.21	-4.10						
	12/15/95	9.25	9.38	-0.13	8.32	12.30	-3.98						
	12/29/95	9.25	9.25	0.00	8.18	12.33	-4.15						
	1/16/96	9.17	9.31	-0.14	7.98	12.36	-4.38						
	1/31/96	8.86	9.11	-0.25	8.00	12.26	-4.28						
	2/15/96	9.46	9.76	-0.30	8.16	12.87	-4.71						
	3/4/96	9.12	9.22	-0.10	8.39	11.59	-3.20						
	3/16/96	8.88	8.98	-0.10	8.21	11.16	-2.95						
	3/29/96	8.68	8.77	-0.09	7.77	11.23	-3.46						
	4/15/96	9.05	9.11	-0.06	7.85	12.10	-4.25						
	5/15/96	8.98	9.14	-0.16	8.20	11.65	-3.45						
	6/14/96	8.84	9.24	-0.40	8.14	11.75	-3.61						
	7/16/96	9.17	9.39	-0.22	8.10	12.96	-4.86						
	8/15/96	8.80	9.12	-0.32	7.81	11.82	-4.01						
	9/16/96	8.89	9.20	-0.31	7.66	12.17	-4.51						
	10/16/96	8.86	9.33	-0.47	7.75	12.32	-4.57						
	11/16/96	8.89	9.35	-0.46	8.01	12.29	-4.28						
	12/16/96	9.05	9.12	-0.07	8.00	12.14	-4.14						
	1/15/97	8.80	8.89	-0.09	7.70	11.56	-3.86						
	2/13/97	8.71	8.82	-0.11	7.66	11.34	-3.68						
	3/17/97	8.65	8.85	-0.20	7.67	11.50	-3.83						
	4/14/97	8.69	8.84	-0.15	7.80	11.45	-3.65						
	5/14/97	8.78	8.99	-0.21	8.00	11.69	-3.69						

Table C-1. Tabulated Surface Water and Ground Water Levels.

Well Name	Date Of Collection	Levee Well	Levee Well	Water Level Diff.	Water Level Seepage Canal (OUT)	ENR (IN)	Surface Water Diff.	WCA Stage	ENR Stage	Stage Diff.	Piezometers Adjacent To Levee Wells (WCA) Out	(ENR) In	Piezometer Difference
	12/29/95	8.88	10.02	-1.14	8.19	13.18	-4.99						
	1/16/96	8.73	9.98	-1.25	7.99	13.18	-5.19						
	1/31/96	8.75	10.34	-1.59	7.98	13.02	-5.04						
	2/15/96	8.93	10.70	-1.77	8.16	13.40	-5.24						
	3/4/96	8.92	9.75	-0.83	8.39	12.46	-4.07						
	3/16/96	8.72	9.57	-0.85	8.19	12.14	-3.95						
	3/29/96	8.44	9.17	-0.73	7.77	12.19	-4.42						
	4/15/96	8.52	9.48	-0.96	7.85	12.90	-5.05						
	5/15/96	8.58	9.62	-1.04	8.19	12.50	-4.31						
	6/14/96	8.56	10.98	-2.42	8.11	12.57	-4.46						
	7/16/96	8.62	10.71	-2.09	8.10	12.96	-4.86						
	8/15/96	8.48	10.49	-2.01	7.80	12.62	-4.82						
	9/16/96	8.40	10.38	-1.98	7.65	12.90	-5.25						
	10/15/96	8.51	10.84	-2.33	7.72	13.20	-5.48						
	11/15/96	8.47	10.74	-2.27	8.01	13.21	-5.20						
	12/15/96	8.55	9.08	-0.53	8.02	12.96	-4.94						
	1/15/97	8.31	8.71	-0.40	7.69	12.42	-4.73						
	2/13/97	8.24	8.67	-0.43	7.62	12.24	-4.62						
	3/17/97	8.11	8.58	-0.47	7.66	12.38	-4.72						
	4/14/97	8.22	8.64	-0.42	7.78	12.29	-4.51						
	5/14/97	8.37	8.86	-0.49	7.98	12.40	-4.42						
	6/16/97	8.60	9.39	-0.79	8.00	12.59	-4.59						
	7/16/97	8.76	10.48	-1.72	8.02	13.24	-5.22						
	8/19/97	8.54	10.36	-1.82	7.91	12.90	-4.99						
	9/15/97	8.58	11.54	-2.96	7.70	13.36	-5.66						
	10/15/97	8.55	10.09	-1.54	7.74	13.15	-5.41						
	11/17/97	8.58	10.52	-1.94	7.78	13.29	-5.51						
	12/15/97	8.56	11.44	-2.88	7.85	13.41	-5.56						
P07		P07A	P07B		Seepage	ENR							

Table C-1. Tabulated Surface Water and Ground Water Levels.

Well Name	Date of Collection	Levee Well	Levee Well	Water Level Diff.	Water Level Seepage Canal (OUT)	ENR (IN)	Surface Water Diff.	WCA Stage	ENR Stage	Stage Diff.	Piezometers Adjacent To Levee Wells (WCA) Out	(ENR) in	Piezometer Difference
	12/5/94	9.42	8.95	0.47		12.15							
	1/25/95	8.62	8.58	0.04	8.12	11.40	-3.28						
	3/7/95	8.48	8.44	0.04	7.96	10.99	-3.04						
	3/20/95	8.73	8.70	0.03	8.03	11.01	-2.88						
	4/11/95	9.37	9.32	0.05	8.84	10.93	-2.09						
	4/28/95	8.32	7.78	0.54	9.26	11.60	-3.36						
	5/16/95	8.46	8.41	0.05	7.85	10.80	-2.85						
	6/7/95	8.73	8.68	0.05	8.21	10.91	-2.70						
	8/15/95	8.41	8.36	0.05	7.80	10.78	-2.59						
	8/30/95	8.66	8.60	0.06	8.06	11.13	-3.08						
	7/14/95	8.74	8.69	0.05	8.21	10.82	-2.81						
	7/31/95	8.87	8.82	0.05	8.30	11.34	-2.74						
	8/16/95	8.74	8.67	0.07	8.09	11.24	-3.15						
	9/31/95	8.56	8.49	0.07	7.90	13.96	-3.03						
	8/15/95	8.72	8.70	0.02	8.20	10.72	-2.52						
	9/29/95	8.69	8.63	0.06	8.00	11.17	-3.17						
	10/19/95	8.69	8.60	0.09	7.84	11.88	-4.04						
	10/31/95	8.87	8.87	0.00	8.28	11.20	-2.82						
	11/15/95	8.84	8.78	0.06	8.21	11.24	-3.03						
	11/30/95	8.81	8.77	0.04	8.18	11.12	-2.94						
	2/15/95	8.96	8.89	0.07	8.26	11.54	-3.28						
	2/29/95	8.95	8.89	0.06	8.19	11.54	-3.65						
	1/16/96	8.78	8.73	0.05	7.98	11.78	-3.80						
	1/31/96	8.66	8.60	0.06	7.92	11.18	-3.29						
	2/15/96	8.70	8.66	0.04	8.16	11.19	-2.94						
	3/4/96	8.93	8.88	0.05	8.36	11.21	-2.85						
	3/16/96	8.87	8.81	0.06	8.16	11.12	-2.96						
	3/29/96	8.56	8.49	0.07	7.75	11.15	-3.37						
	4/15/96	8.50	8.49	0.11	7.75	11.17	-3.41						
	5/15/96	8.91	8.75	0.06	8.16	11.27	-3.11						
	6/14/96	8.75	8.71	0.05	8.08	11.22	-3.13						

Table C-1. Tabulated Surface Water and Ground Water Levels.

Well Name	Date Of Collection	Levee Well	Levee Well	Water Level Diff.	Water Level Seepage Canal (OUT)	ENR (IN)	Surface Water Diff.	WCA Stage	ENR Stage	Stage Diff.	Piezometers		Piezometer Difference
											Adjacent To Levee Wells (WCA) Out	(ENR) In	
	7/14/95		13.92					5.81	10.84	4.37	14.51	13.28	1.25
	7/31/95		14.54					6.88	10.87	5.81	15.93	13.55	2.38
	8/15/95		14.22					6.04	10.75	5.29	15.23	13.48	1.74
	8/31/95		14.95					17.51	10.60	6.91	16.68	13.65	3.03
	9/15/95		14.84					17.25	11.06	6.17	16.30	13.55	2.75
	9/29/95		14.58					16.73	11.84	4.89	15.69	12.55	3.14
	10/18/95		15.26					18.29	11.14	7.14	17.04	13.59	3.45
	10/31/95		14.86					17.53	11.12	6.41	16.24	13.50	2.74
	1/15/95		14.67					16.90	11.05	5.82	15.76	13.50	2.26
	1/30/95		14.68					16.93	11.47	5.46	15.73	12.64	3.09
	12/15/95		14.88					16.91	11.77	5.14	15.07	13.47	1.60
	12/29/95		14.67					16.81	11.81	5.00	15.73	13.56	2.17
	1/16/96		14.63					16.86	11.81	5.05	15.82	13.66	2.16
	1/31/96		14.82					16.89	11.07	5.82	15.77	13.52	2.25
	2/15/96		14.31					15.39	10.79	5.60	15.50	13.41	2.09
	3/14/96		14.22					16.19	11.20	4.99	15.41	13.38	2.03
	3/16/96		14.41					16.42	11.14	5.28	15.71	13.47	2.24
	3/29/96		14.25					16.11	11.22	4.89	15.34	13.42	1.92
	4/16/96		13.85					15.32	11.13	4.19	14.26	13.26	1.00
	5/15/96		13.92					15.62	11.15	4.47	14.44	13.16	1.28
	6/14/96		14.53					16.82	11.24	5.58	16.12	13.55	2.57
	7/16/96		14.11					15.82	11.52	4.30	14.83	13.36	1.47
	8/15/96		14.01					15.79	11.18	4.61	14.67	13.39	1.28
	8/16/96		14.55					16.70	11.13	5.57	15.89	13.56	2.33
	10/16/96		14.83					17.17	11.67	5.50	16.44	13.60	2.84
	1/15/97		14.72								16.22	13.69	2.53
	2/16/97		14.56								15.55	13.58	1.97
	1/15/97		14.41								15.75	13.53	2.22
	2/13/97		14.20								15.44	13.50	1.94
	3/17/97		14.25								15.57	13.60	1.97
	4/14/97		14.16								15.27	13.52	1.75

Table C-1. Tabulated Surface Water and Ground Water Levels.

Well Name	Date Of Collection	Levee Well	Levee Well	Water Level Diff.	Water Level Seepage Canal (OUT)	ENR (IN)	Surface Water Diff.	WCA Stage	ENR Stage	Stage Diff.	Piezometers Adjacent To Levee Wells (WCA) Out	(ENR) In	Piezometer Difference
	5/14/97		13.85								14.30	13.04	1.26
	6/16/97		14.50								15.97	13.56	2.41
	7/16/97		14.43								15.62	13.46	2.16
	8/19/97		14.52								16.09	13.64	2.45
	9/15/97		14.54								16.10	13.64	2.46
	10/15/97		14.62								16.31	13.58	2.73
	11/17/97		14.64								16.35	13.58	2.77
	12/15/97		15.12										
P09													
			P09A										
	12/5/94		12.54										
	1/25/95		12.09										
	3/20/95		11.91										
	4/11/95		12.10										
	4/28/95		13.14										
	5/16/95		11.87										
	6/1/95		11.77										
	6/15/95		11.99										
	6/30/95		11.95										
	7/14/95		12.04										
	7/31/95		12.12										
	8/16/95		12.10										
	8/31/95		12.17										
	9/15/95		12.11										
	9/29/95		12.24										
	10/19/95		12.27										
	10/31/95		12.17										
	11/15/95		12.17										
	11/30/95		12.11										
	12/15/95		12.09										
	12/29/95		12.27										

Table C-1. Tabulated Surface Water and Ground Water Levels.

Well Name	Date Of Collection	Levee Well	Levee Well	Water Level Diff.	Water Level Seepage Canal (OUT)	ENR (IN)	Surface Water Diff.	WCA Stage	ENR Stage	Stage Diff.	Piezometers Adjacent To Levee Wells (WCA) Out	(ENR) In	Piezometer Difference
	1/25/95	14.52	15.50	-0.98				16.38	11.39	4.99			
	3/7/95	14.43	15.47	-1.04				16.31	10.97	5.34	16.29	14.70	1.59
	3/20/95	14.50	15.49	-0.99				16.42	11.30	5.12	16.34	14.63	1.71
	4/11/95	14.27	15.12	-0.85				15.75	12.25	3.50	15.63	14.65	0.98
	4/28/95	14.00	14.98	-0.98				15.58	11.50	4.08	15.35	14.63	0.72
	5/16/95	13.89	14.94	-1.05				15.32	11.07	4.25	15.25	14.63	0.62
	6/1/95	13.74	14.84	-1.10				15.19	10.94	4.25	15.07	14.58	0.49
	6/15/95	14.05	15.08	-1.03				15.59	11.07	4.52	15.55	14.65	0.90
	6/30/95	14.11	15.07	-0.96				15.60	11.54	4.06	15.46	14.64	0.82
	7/14/95	14.06	15.09	-1.03				15.81	11.13	4.68	15.52	14.68	0.84
	7/31/95	14.69	15.60	-0.91				16.68	11.78	4.90	16.58	14.72	1.86
	8/16/95	14.37	15.32	-0.95				16.04	11.70	4.34	15.92	14.71	1.21
	8/31/95	15.13	16.15	-1.02				17.52	11.76	5.76	17.49	14.70	2.79
	9/15/95	14.98	16.03	-1.05				17.26	11.37	5.89	17.24	14.73	2.51
	9/29/95	14.76	15.64	-0.88				16.75	11.91	4.84	16.61	14.71	1.90
	10/19/95	15.62	16.52	-0.90				18.35	12.36	5.99	18.26	14.76	3.50
	10/31/95	16.16	16.16	0.00				17.55	11.69	5.86	17.49	14.72	2.77
	11/15/95	14.86	15.73	-0.87				16.91	11.79	5.12	16.80	14.72	2.08
	11/30/95	14.89	15.76	-0.87				16.93	11.82	5.11	16.81	14.68	2.13
	12/15/95	14.89	15.73	-0.84				16.91	11.98	4.93	16.82	14.70	2.12
	12/29/95	14.87	15.62	-0.75				16.80	12.12	4.68	16.68	14.69	1.99
	1/16/96	14.87	15.63	-0.76				16.84	12.14	4.70	16.74	14.71	2.03
	1/31/96	14.84	15.67	-0.83				16.87	11.92	4.95	16.74	14.72	2.02
	2/15/96	14.47	15.41	-0.94				16.20	11.12	5.08	16.20	14.67	1.53
	3/4/96	14.35	15.34	-0.99				15.99	11.17	4.82	15.99	14.68	1.31
	3/16/96	14.66	15.48	-0.82				16.31	12.29	4.02	16.31	14.69	1.62
	3/29/96	14.40	15.34	-0.94				16.01	11.58	4.43	16.01	14.68	1.33
	4/15/96	14.08	14.95	-0.87				15.19	11.78	3.41	15.19	14.62	0.57
	5/15/96	14.09	15.74	-1.65				15.53	11.40	4.13	15.53	14.68	0.85
	6/14/96	14.78	15.74	-0.96				16.82	11.63	5.19	16.82	14.75	2.07
	7/16/96	14.32	15.21	-0.89				15.66	12.03	3.63	15.66	14.64	1.02

Table C-1. Tabulated Surface Water and Ground Water Levels.

Well Name	Date Of Collection	Levee Well	Levee Well	Water Level Diff.	Water Level Seepage Canal (OUT)	ENR (IN)	Surface Water Diff.	WCA Stage	ENR Stage	Stage Diff.	Piezometers Adjacent To Levee Wells (WCA) Out	(ENR) In	Piezometer Difference
	7/31/95	12.04	12.01	0.03	12.02	12.20	-0.18						
	8/16/95	11.94	12.01	-0.07	11.98	12.20	-0.22						
	8/31/95	12.05	11.58	0.47	11.89	12.16	-0.27						
	9/15/95	11.62	11.34	0.28	11.58	11.66	-0.08						
	9/29/95	12.09	11.66	0.43	12.02	12.22	-0.20						
	10/19/95	12.36	11.88	0.48	12.29	12.50	-0.21						
	10/31/95	11.77	11.77	0.00	11.74	11.98	-0.24						
	11/15/95	12.01	11.78	0.23	11.92	12.17	-0.25						
	11/30/95	12.08	11.71	0.37	11.96	12.22	-0.26						
	12/15/95	12.15	11.77	0.38	12.05	12.30	-0.25						
	12/29/95	12.24	11.83	0.41	12.16	12.32	-0.16						
	1/16/96	12.27	11.93	0.34	12.15	12.38	-0.23						
	1/31/96	12.15	11.83	0.32	12.02	12.32	-0.30						
	2/15/96	11.95	11.52	0.33	11.39	12.44	-1.05						
	3/4/96	11.34	11.16	0.18	11.28	11.32	-0.04						
	3/16/96	11.75	11.14	0.61	12.60	11.12	1.48						
	3/29/96	11.49	12.81	-1.32	11.90	11.20	0.70						
	4/15/96	12.08	11.48	0.60	12.16	11.90	0.26						
	5/15/96	11.56	11.19	0.37	11.65	11.45	0.20						
	6/14/96	11.69	11.45	0.24	11.87	11.57	0.30						
	7/16/96	12.16	11.86	0.30	12.32	12.00	0.32						
	8/15/96	11.74	11.55	0.19	11.90	12.65	-0.75						
	9/16/96	12.03	11.12	0.91	11.15	11.92	-0.77						
	10/16/96	12.25	11.69	0.56	12.31	12.30	0.01						
	11/15/96	12.28	11.90	0.38	12.38	12.17	0.21						
	12/16/96	12.03	11.44	0.59	12.18	11.96	0.22						
	1/15/97	0.00	0.00	0.00	0.00	0.00	0.00						
	2/13/97	11.33	11.04	0.29	11.45	11.20	0.25						
	3/17/97	11.48	11.08	0.40	11.61	11.35	0.26						
	4/14/97	15.00	11.01	3.99	11.57	11.31	0.26						
	5/14/97	11.68	11.07	0.61	11.90	11.47	0.43						

Table C-1. Tabulated Surface Water and Ground Water Levels.

Well Name	Date Of Collection	Levee Well	Levee Well	Water Level Diff.	Water Level Seepage Canal (OUT)	ENR (IN)	Surface Water Diff.	WCA Stage	ENR Stage	Stage Diff.	Piezometers Adjacent To Levee Wells (WCA) Out	(ENR) In	Piezometer Difference
	12/29/95	14.62	14.60	0.02				16.80	12.33	4.47	16.82	14.26	2.56
	1/15/96	14.63	14.61	0.02				16.84	12.37	4.47	16.89	14.19	2.70
	1/31/96	14.63	14.59	0.04				16.87	12.32	4.55	16.88	14.15	2.73
	2/15/96	14.22	14.24	-0.02				16.36	11.40	4.96	16.36	14.13	2.23
	3/4/96	14.07	14.06	0.01				16.11	11.25	4.86	16.11	14.22	1.89
	3/16/96	14.48	14.45	0.03				16.40	12.56	3.84	16.40	14.26	2.14
	3/29/96	14.20	14.17	0.03				16.12	11.94	4.18	16.12	14.19	1.93
	4/15/96	13.95	13.97	-0.02				15.29	12.18	3.11	15.29	13.95	1.34
	5/15/96	13.91	13.88	0.03				15.59	11.86	3.93	15.59	13.99	1.60
	6/14/96	14.52	14.53	-0.01				16.88	11.87	5.01	16.88	14.10	2.78
	7/16/96	14.20	14.21	-0.01				15.81	12.33	3.48	16.51	14.21	2.30
	8/15/96	14.03	14.01	0.02				15.73	11.91	3.82	15.75	14.09	1.66
	9/16/96	14.57	14.56	0.01				16.66	12.21	4.45	16.69	14.17	2.52
	10/16/96	14.76	14.76	0.00				17.16		17.16	17.16	14.25	2.91
	11/15/96	14.67	14.66	0.01							16.93	14.26	2.67
	12/16/96	14.37	14.35	0.02							16.35	14.23	2.12
	1/15/97	14.35	14.30	0.05							16.46	14.31	2.15
	2/13/97	14.12	14.12	0.00							16.13	14.17	1.96
	3/17/97	14.21	14.20	0.01							16.26	14.14	2.12
	4/14/97	14.11	14.09	0.02							15.98	14.17	1.81
	5/14/97	13.92	13.92	0.00							15.52	13.84	1.68
	6/16/97	14.48	14.47	0.01							16.71	14.16	2.55
	7/16/97	14.32	14.32	0.00							16.23	14.17	2.06
	8/19/97	14.52	14.50	0.02							16.83	14.25	2.58
	9/15/97	14.48	14.47	0.01							16.79	14.33	2.46
	10/15/97	14.56	14.56	0.00							17.02	14.32	2.70
	11/17/97	14.57	14.57	0.00							17.06	14.31	2.75
	12/15/97	15.07	15.07	0.00							18.04	14.34	3.70
P13		P13A	P13B					ENR 003	ENR101				
	12/5/94	15.25	15.32	-0.07				17.62			21.24	18.92	2.32

Table C-1. Tabulated Surface Water and Ground Water Levels.

Well Name	Date Of Collection	Levee Well	Levee Well	Water Level Diff.	Water Level Seepage Canal (OUT)	ENR (IN)	Surface Water Diff.	WCA Stage	ENR Stage	Stage Diff.	Piezometers		Piezometer Difference
											To Levee Wells (WCA) Out	(ENR) In	
	1/25/95	14.54	14.70	-0.16				16.38	11.43	4.95			
	3/7/95	14.35	14.57	-0.21				16.31	11.12	5.19	15.37	14.27	2.10
	3/20/95	14.48	14.68	-0.20				16.42	11.68	4.74	15.45	14.27	2.18
	4/11/95	14.32	14.46	-0.14				15.75	12.79	2.96	15.69	14.21	1.48
	4/28/95	13.65	14.10	-0.45				15.58	11.60	3.98	15.40	14.12	1.28
	5/16/95	14.52	13.58	0.94				15.32	11.35	3.97	15.30	14.01	1.29
	5/1/95	13.57	13.76	-0.19				15.19	11.06	4.13	15.14	13.85	1.28
	8/15/95	13.96	14.14	-0.18				15.59	11.31	4.28	15.55	14.13	1.42
	8/30/95	14.12	14.29	-0.17				15.60	12.04	3.56	15.50	14.13	1.37
	7/14/95	14.10	14.28	-0.18				15.81	11.75	4.06	15.54	14.20	1.34
	7/31/95	14.68	14.88	-0.20				16.68	12.34	4.34	16.65	14.24	2.41
	8/13/95	14.36	14.54	-0.18				16.84	12.11	4.73	16.01	14.24	1.77
	8/31/95	15.06	15.26	-0.20				17.52	12.23	5.29	17.52	14.21	3.31
	9/15/95	15.30	15.12	0.18				17.26	11.72	5.54	17.28	14.26	3.02
	9/23/95	14.74	14.96	-0.22				16.75	12.35	4.40	16.73	14.24	2.49
	10/19/95	15.52	15.73	-0.21				18.35	12.62	5.73	18.40	14.50	4.10
	10/21/95	15.10	15.32	-0.22				17.55	12.07	5.48	17.55	14.26	3.29
	11/15/95	14.82	15.04	-0.22				16.81	12.27	4.54	16.91	14.25	2.66
	11/30/95	14.84	15.05	-0.21				16.93	12.33	4.60	16.80	14.25	2.64
	12/15/95	14.84	15.02	-0.18				16.81	12.37	4.44	16.90	14.22	2.68
	1/22/96	14.82	14.99	-0.17				16.80	12.35	4.45	16.85	14.28	2.57
	1/13/96	14.82	14.98	-0.16				16.84	12.41	4.43	16.91	14.28	2.63
	1/31/96	14.80	14.98	-0.18				16.87	12.37	4.50	16.88	14.28	2.60
	2/15/96	14.41	14.61	-0.20				16.41	11.42	4.99	16.41	14.27	2.14
	3/4/96	14.26	14.43	-0.20				16.17	11.22	4.94	16.17	14.26	1.91
	3/15/96	14.65	14.82	-0.17				16.42	12.63	3.79	16.42	14.26	2.16
	3/29/96	14.40	14.59	-0.19				16.14	11.89	4.25	16.14	14.27	1.87
	4/15/96	14.12	14.27	-0.15				15.35	12.30	3.05	15.35	14.12	1.23
	5/15/96	14.08	14.27	-0.19				15.64	11.76	3.88	15.64	14.24	1.40
	6/14/96	14.73	14.95	-0.22				15.95	11.93	5.02	16.95	14.30	2.65
	7/16/96	14.38	14.56	-0.18				15.83	12.49	3.34	15.83	14.31	2.42

Table C-1. Tabulated Surface Water and Ground Water Levels.

Well Name	Date Of Collection	Levee Well	Levee Well	Water Level Diff.	Water Level Seepage Canal (OUT)	ENR (IN)	Surface Water Diff.	WCA Stage	ENR Stage	Stage Diff.	Piezometers Adjacent To Levee Wells (WCA) Out	(ENR) In	Piezometer Difference
	8/15/96	14.19	14.38	-0.19				15.78	11.95	3.83	15.78	14.07	1.71
	9/16/96	14.75	14.94	-0.19				16.63	12.42	4.21	16.63	14.25	2.38
	10/16/96	14.94	15.13	-0.19				17.20		17.20	17.20	14.23	2.97
	11/15/96	14.84	15.04	-0.20							16.96	14.29	2.67
	12/16/96	14.53	14.71	-0.18							16.35	14.31	2.04
	1/15/97	14.49	14.67	-0.18							16.45	14.26	2.19
	2/13/97	14.30	14.48	-0.18							16.14	14.25	1.89
	3/17/97	14.37	14.57	-0.20							16.28	14.28	2.00
	4/14/97	14.30	14.58	-0.28							16.00	14.29	1.71
	5/14/97	14.11	14.23	-0.12							15.77	14.13	1.64
	6/16/97	14.65	14.84	-0.19							16.73	14.26	2.47
	7/16/97	14.47	14.67	-0.20							16.26	14.21	2.05
	8/19/97	14.69	14.97	-0.28							16.86	14.24	2.62
	9/15/97	14.52	14.78	-0.26							16.80	14.30	2.50
	10/15/97	14.59	14.86	-0.27							17.03	14.27	2.76
	11/17/97	14.62	14.92	-0.30							17.06	14.30	2.76
	12/15/97	15.22	15.43	-0.21							18.07	14.34	3.73
P14			P14B					ENR 005	ENR 012				
	12/5/94		14.98										
	1/25/95		14.28					16.37	11.33	5.04			
	3/20/95		14.27					16.42	10.88	5.54	14.36	14.84	-0.48
	4/11/95		13.92					15.77	10.97	4.80	14.56	13.35	1.21
	4/28/95		13.83					15.59	11.14	4.45	14.39	13.20	1.19
	5/16/95		13.56					15.39	10.81	4.52	14.30	13.05	1.25
	6/1/95		13.41					15.20	10.85	4.35	14.15	12.80	1.25
	6/15/95		13.82					15.61	10.82	4.79	14.57	13.32	1.25
	6/30/95		13.86					15.61	10.80	4.81	14.45	13.27	1.18
	7/14/95		13.81					15.81	10.78	5.03	14.51	13.26	1.25
	7/31/95		14.40					16.68	10.84	5.84	15.93	13.55	2.38
	8/16/95		14.10					16.04	10.57	5.17	15.23	13.49	1.74

Table C-1. Tabulated Surface Water and Ground Water Levels.

Well Name	Date Of Collection	Levee Well	Levee Well	Water Level Diff.	Water Level Seepage Canal (OUT)	ENR (IN)	Surface Water Diff.	WCA Stage	ENR Stage	Stage Diff.	Piezometers Adjacent To Levee Wells (WCA) Out	(ENR) In	Piezometer Difference
	8/31/95	14.81						17.51	10.75	5.75	17.52	14.2*	3.31
	9/7/95	14.71						17.25	10.60	5.65	17.28	14.26	3.02
	9/29/95	14.45						16.73	11.08	5.65	16.73	14.24	2.49
	10/13/95	15.20						18.28	11.84	5.44	17.04	13.59	3.45
	10/31/95	14.85						17.53	11.14	5.88	16.24	13.50	2.74
	11/15/95	14.53						16.90	11.12	5.78	15.76	13.50	2.26
	11/30/95	14.55						16.93	11.08	5.85	15.73	13.54	2.19
	12/15/95	14.55						16.9*	11.47	5.44	15.67	13.47	2.20
	12/23/95	14.51						16.8*	11.77	5.04	15.73	13.56	2.17
	1/6/96	14.49						16.86	11.81	5.05	15.82	13.66	2.16
	1/31/96	14.47						16.89	11.07	5.82	15.77	13.52	2.25
	2/5/96	14.18						16.89	10.79	5.60	15.50	13.41	2.09
	3/4/96	14.08						16.9	11.20	4.99	15.41	13.38	2.03
	3/16/96	14.24						16.42	11.14	5.28	15.71	13.47	2.24
	3/29/96	14.12						16.11	11.22	4.89	15.34	13.42	1.92
	4/5/96	13.75						15.32	11.13	4.19	14.26	13.26	1.00
	5/5/96	13.83						15.62	11.15	4.47	14.44	13.15	1.28
	6/14/96	14.47						16.82	11.24	5.58	15.12	13.55	2.57
	7/16/96	15.99						15.82	11.52	4.30	14.53	13.36	1.27
	8/15/96	15.92						15.79	11.18	4.6*	14.57	13.39	1.28
	9/15/96	14.45						15.70	11.19	5.5*	15.38	13.58	2.41
	10/6/96	14.67						17.17	11.57	5.50	16.44	13.60	2.84
	11/15/95	14.58									16.22	13.63	2.53
	12/16/96	14.25									15.65	13.60	1.97
	1/15/97	13.86									15.75	13.63	2.12
	2/18/97	14.09									15.44	13.50	1.94
	3/17/97	14.17									15.57	13.60	1.97
	4/14/97	14.06									15.27	13.52	1.75
	5/14/97	13.75									14.30	13.04	1.26
	6/16/97	14.38									15.97	13.56	2.4*
	7/16/97	14.32									15.62	13.46	2.16

Table C-1. Tabulated Surface Water and Ground Water Levels.

Well Name	Date Of Collection	Levee Well	Levee Well	Water Level Diff.	Water Level Seepage Canal (OUT)	ENR (IN)	Surface Water Diff.	WCA Stage	ENR Stage	Stage Diff.	Piezometers Adjacent To Levee Wells (WCA) Out	(ENR) In	Piezometer Difference
	8/19/97		14.41								16.09	13.64	2.45
	9/15/97		14.42								16.10	13.64	2.46
	10/15/97		14.52								16.31	13.58	2.73
	11/17/97		14.52								16.35	13.58	2.77
	12/15/97		14.96								17.11	13.68	3.43

APPENDIX D: Aquifer Performance and Slug Test Analyses

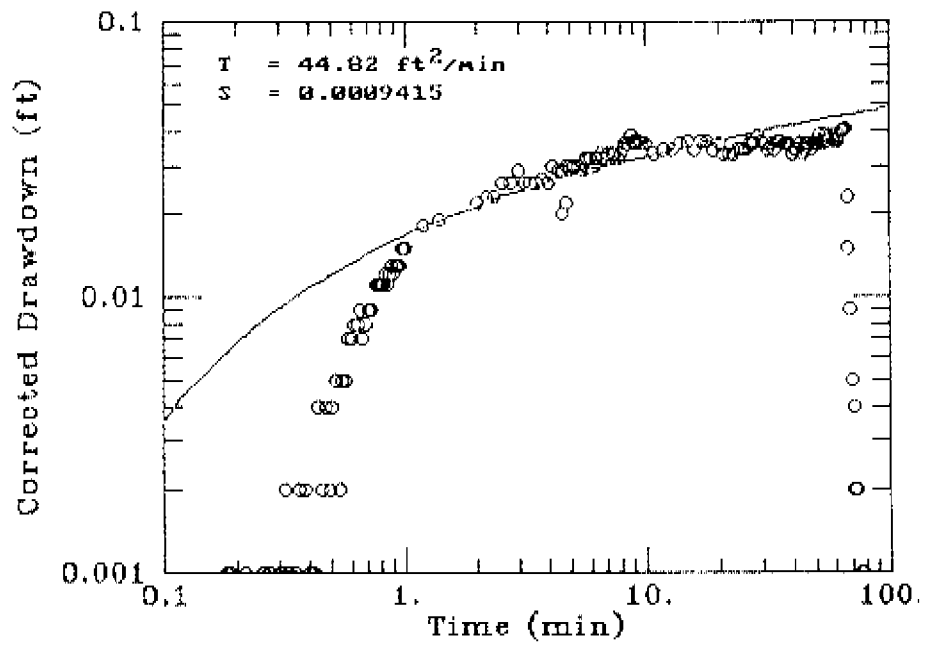

Figure D-1. Analyses of Aquifer Performance Test for PO1B (Theis Method)

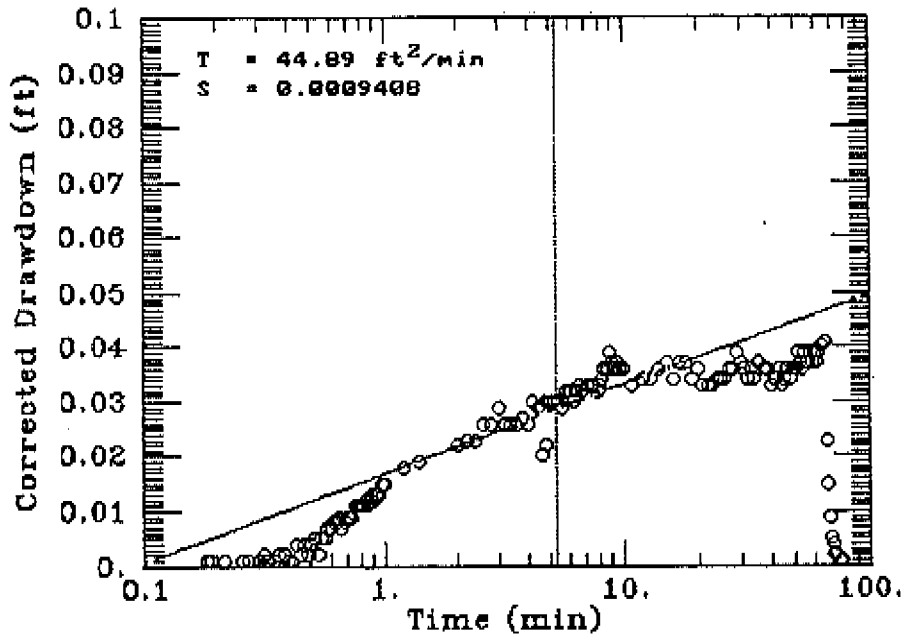

Figure D-2. Analyses of Aquifer Performance Test for PO1B (Cooper-Jacob Method)

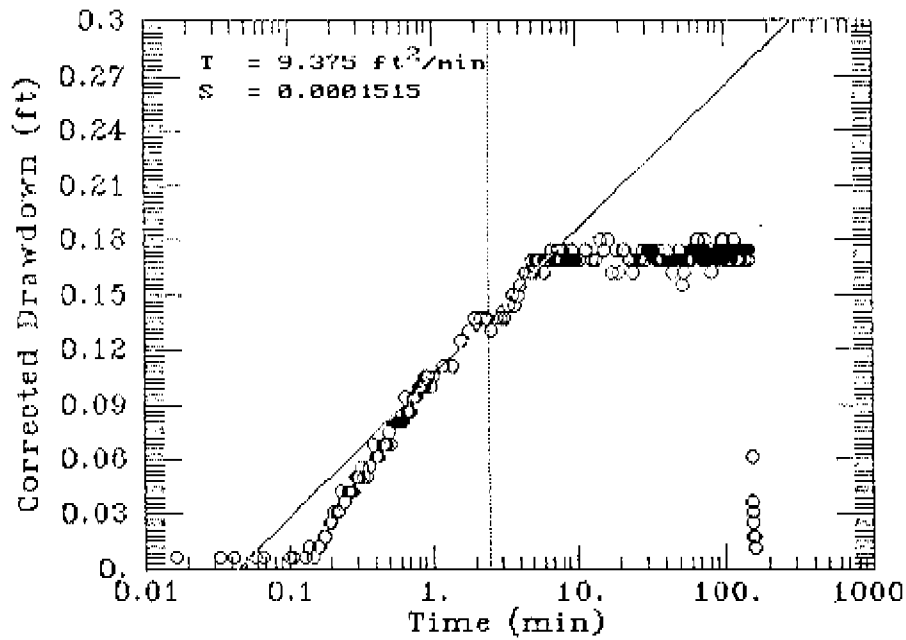

Figure D-3. Analyses of Aquifer Performance Test for P14B
(Theis Method)

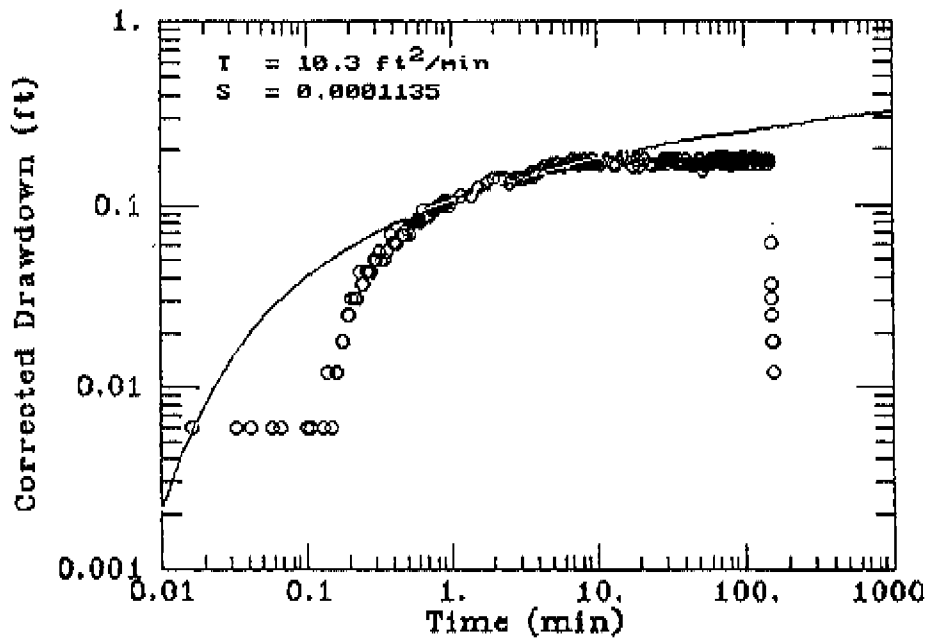

Figure D-4. Analyses of Aquifer Performance Test for P14B
 (Cooper-Jacob Method)

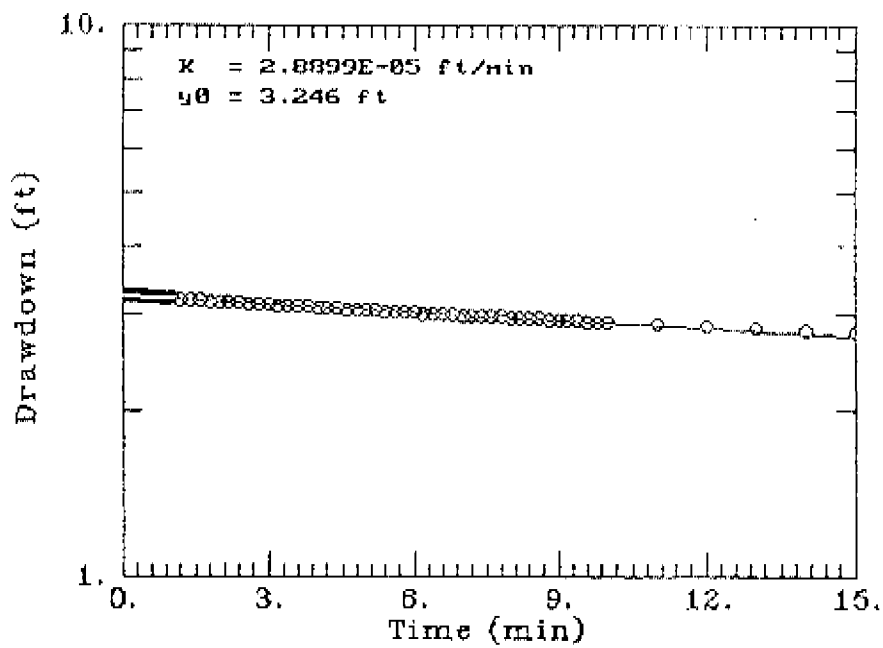

Figure D-5. Analyses of Slug Test for PO2A

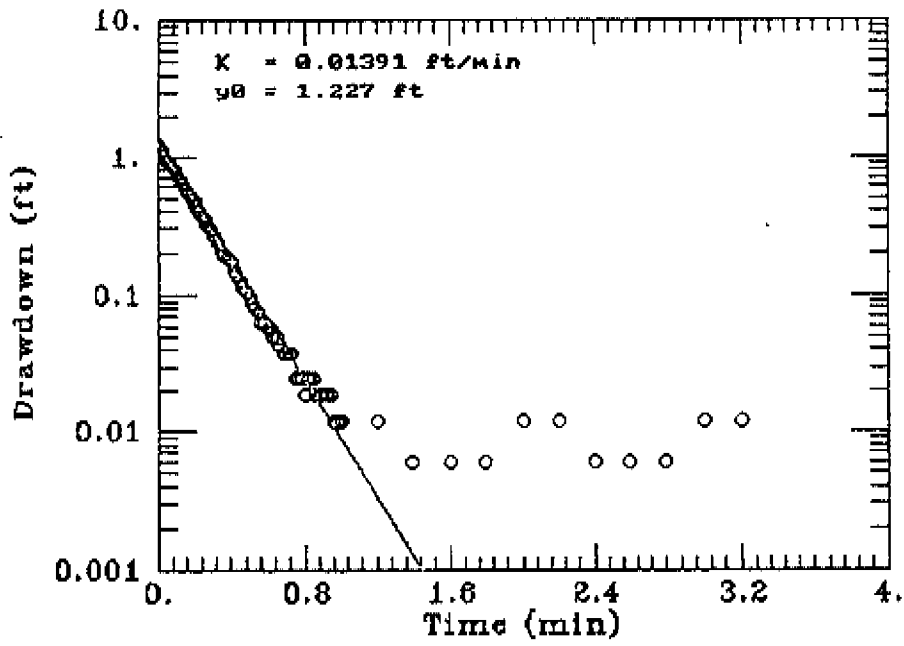

Figure D-6. Analyses of Slug Test for PO2B

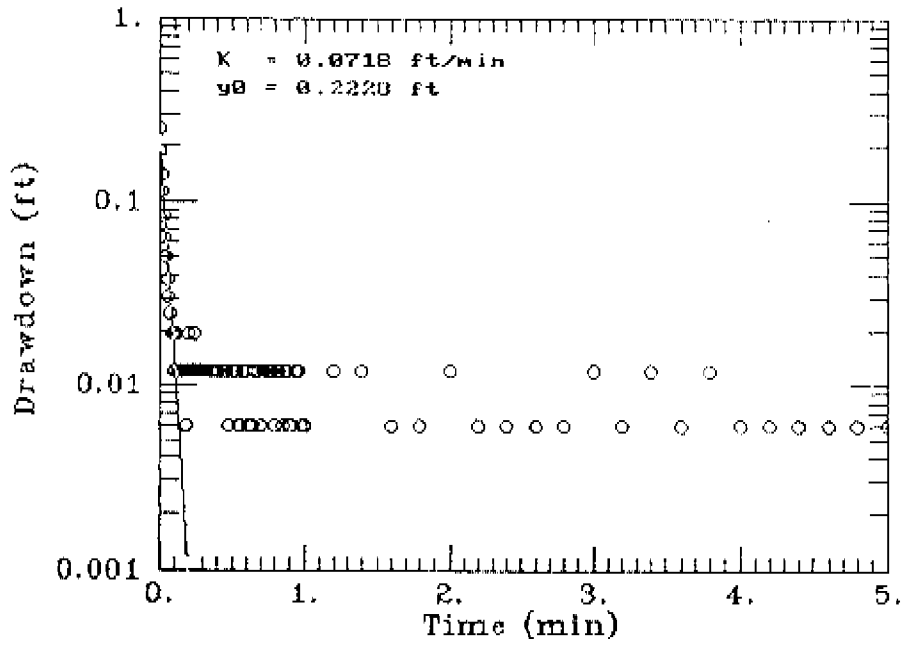

Figure D-7. Analyses of Slug Test for PO3A

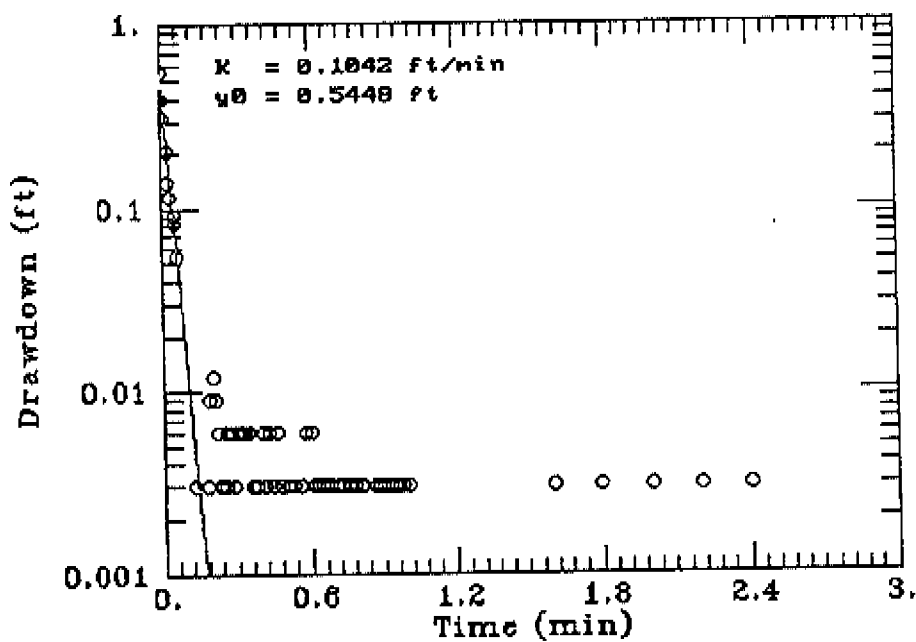

Figure D-8. Analyses of Slug Test for PO3B

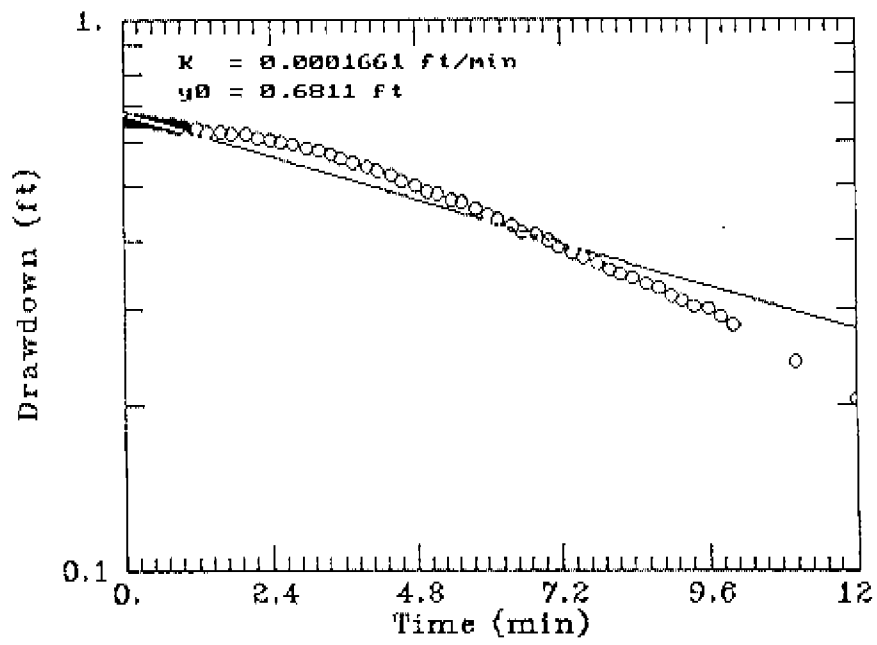

Figure D-9. Analyses of Slug Test for P04A

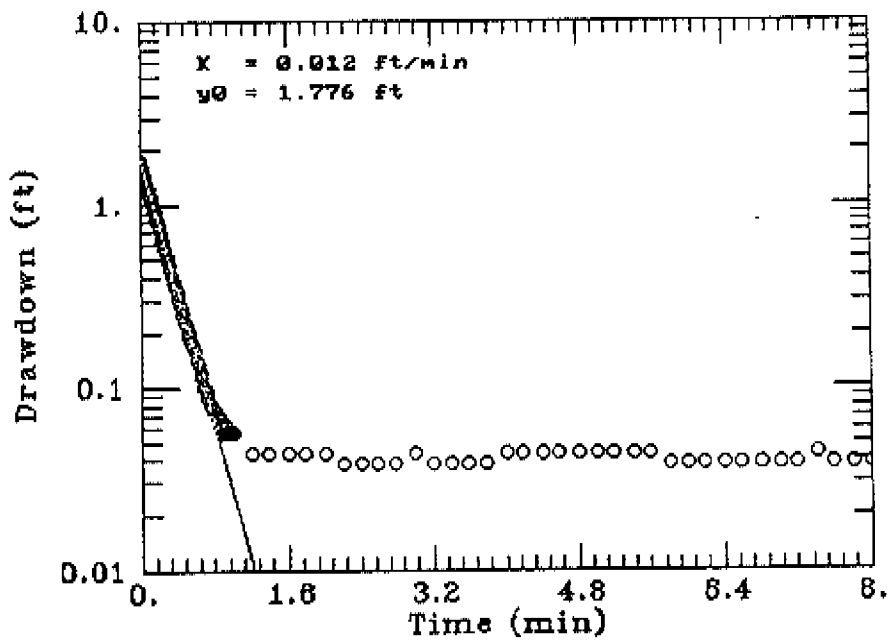

Figure D-10. Analyses of Slug Test for P04B

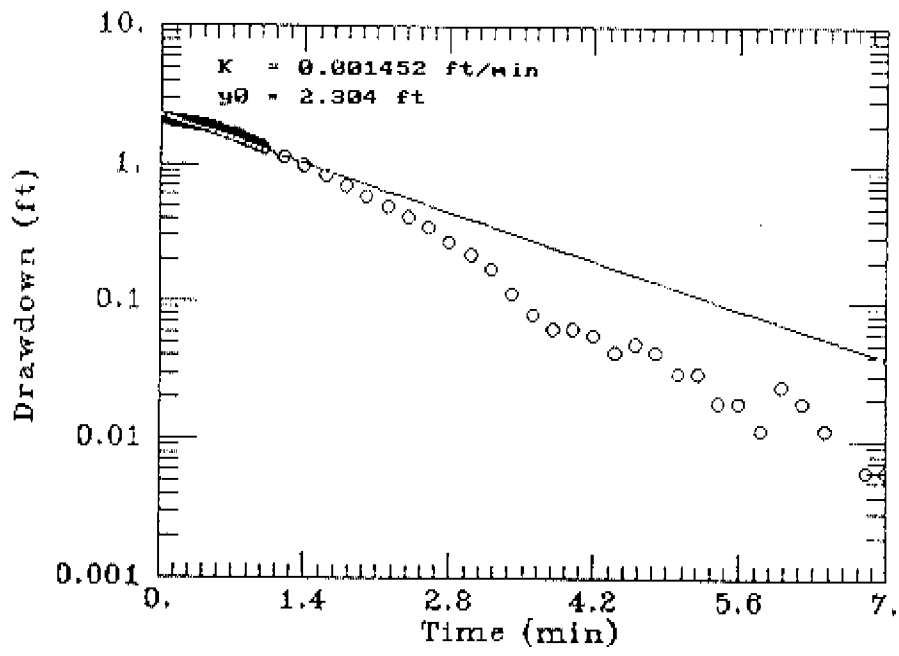

Figure D-11. Analyses of Slug Test for P05A

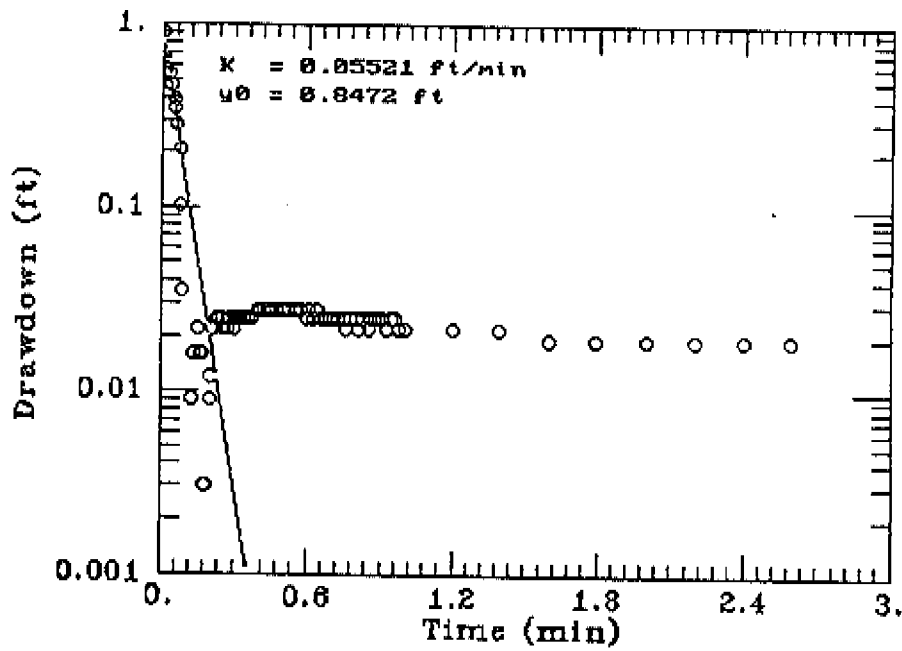

Figure D-12. Analyses of Slug Test for P05B

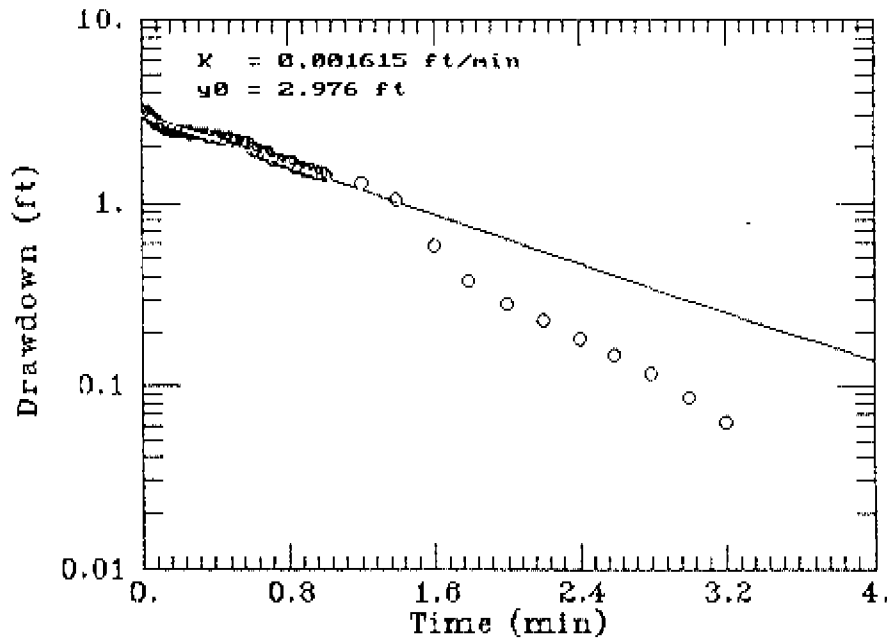

Figure D-13. Analyses of Slug Test for P06A

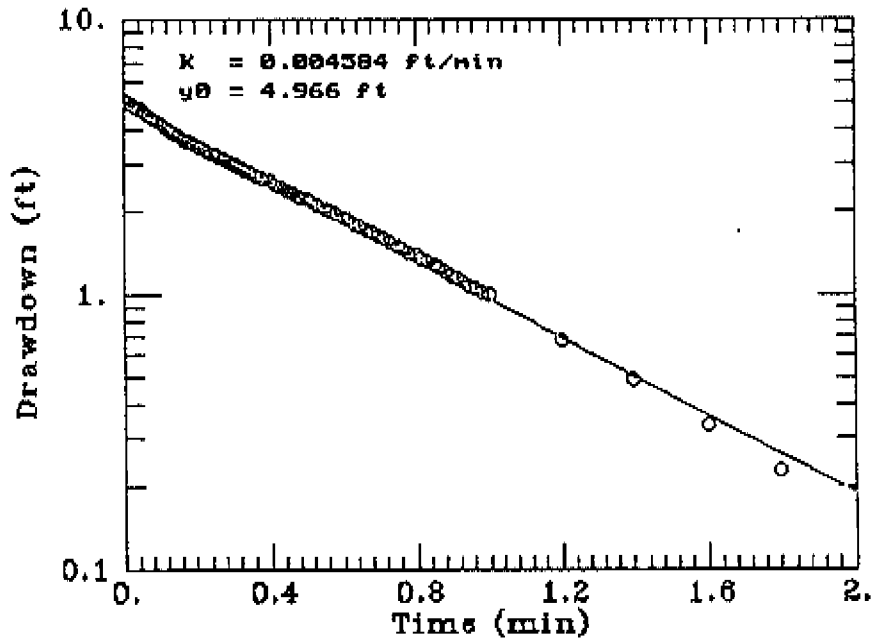

Figure D-14. Analyses of Slug Test for P06B

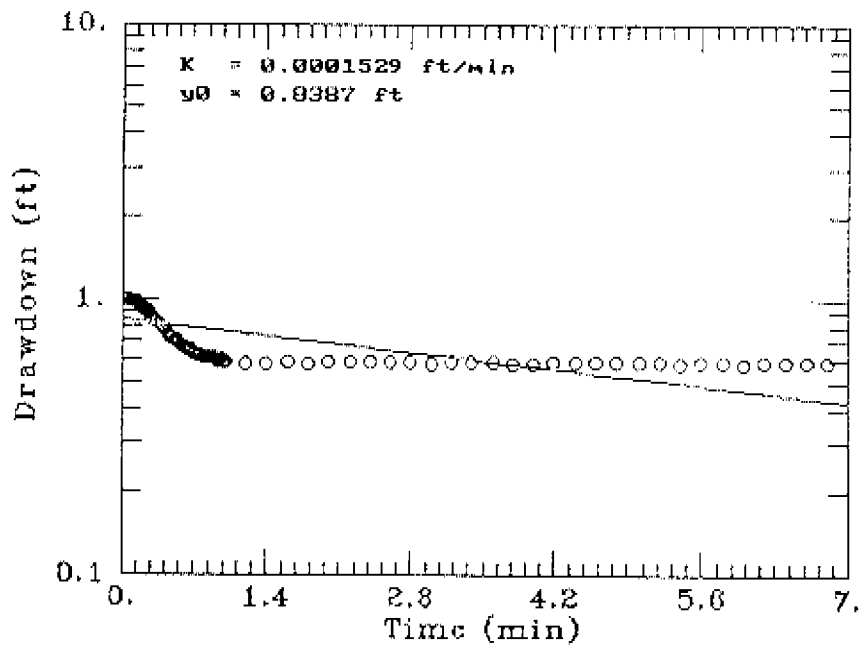

Figure D-15. Analyses of Slug Test for P07A

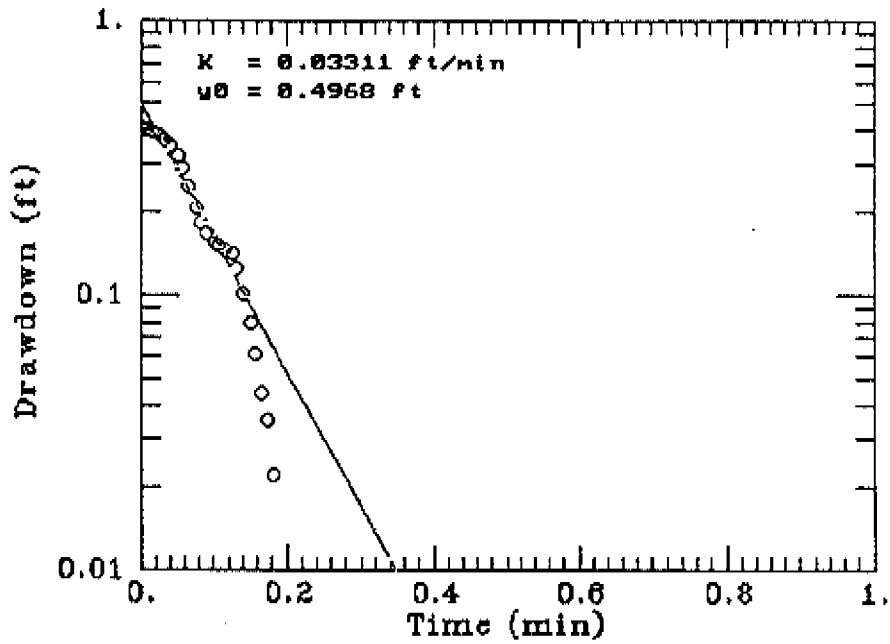

Figure D-16. Analyses of Slug Test for P07B

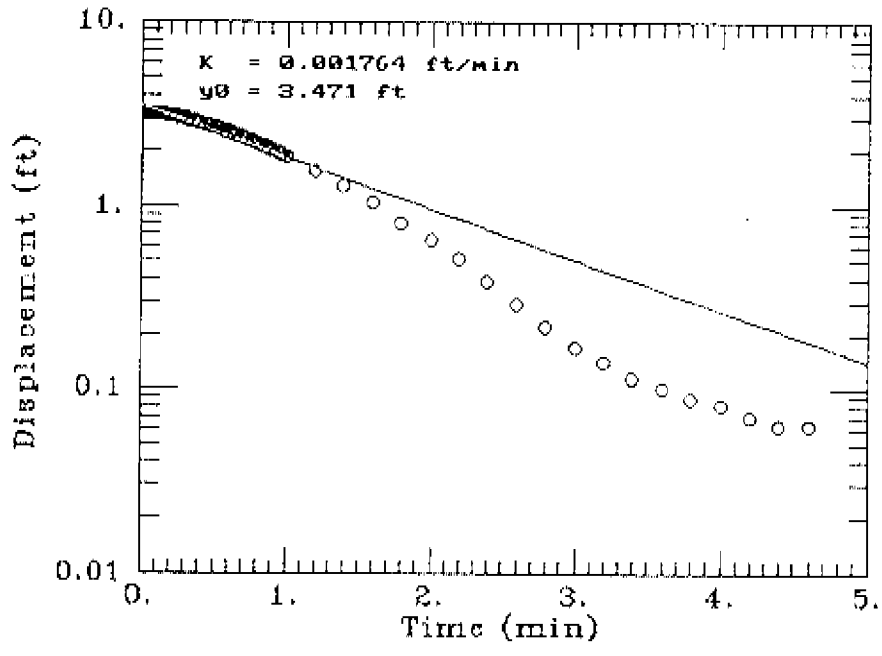

Figure D-17. Analyses of Slug Test for P10A

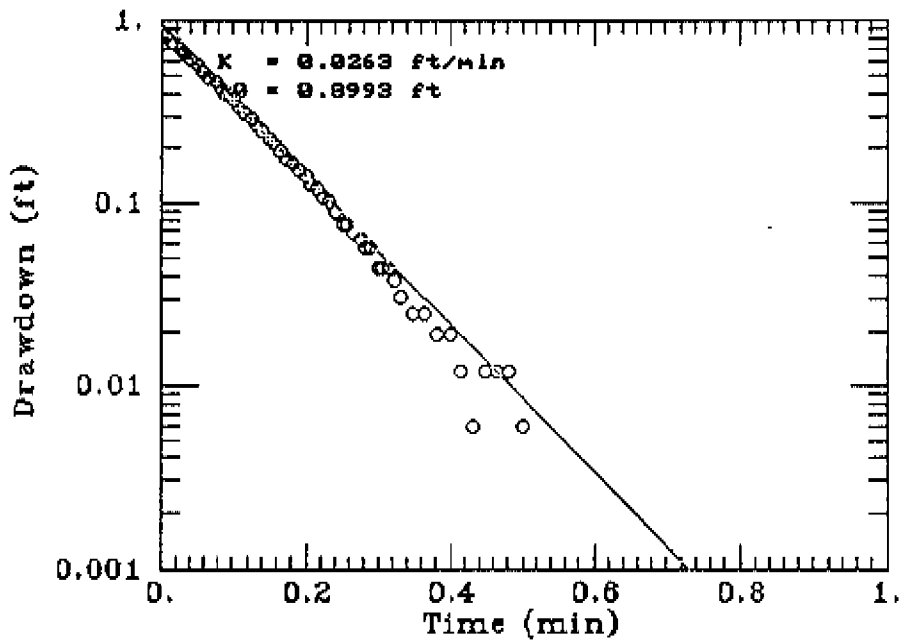

Figure D-18. Analyses of Slug Test for P10B

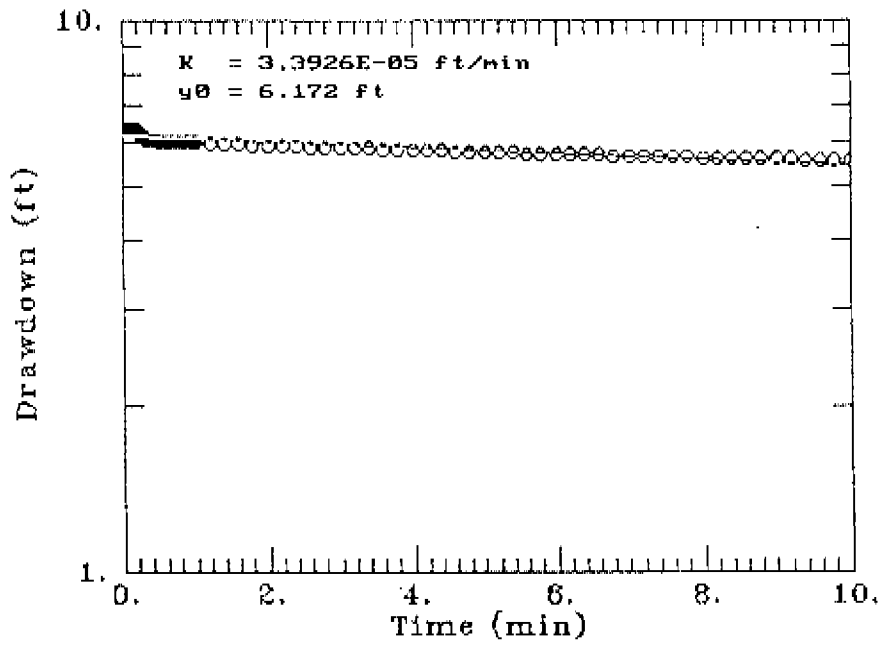

Figure D-19. Analyses of Slug Test for P11A

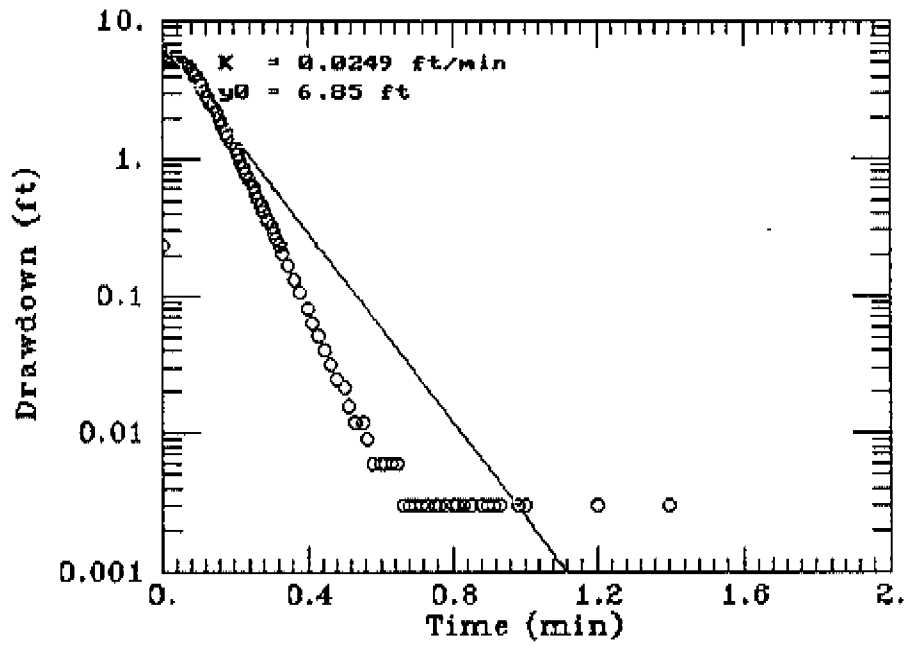

Figure D-20. Analyses of Slug Test for P11B

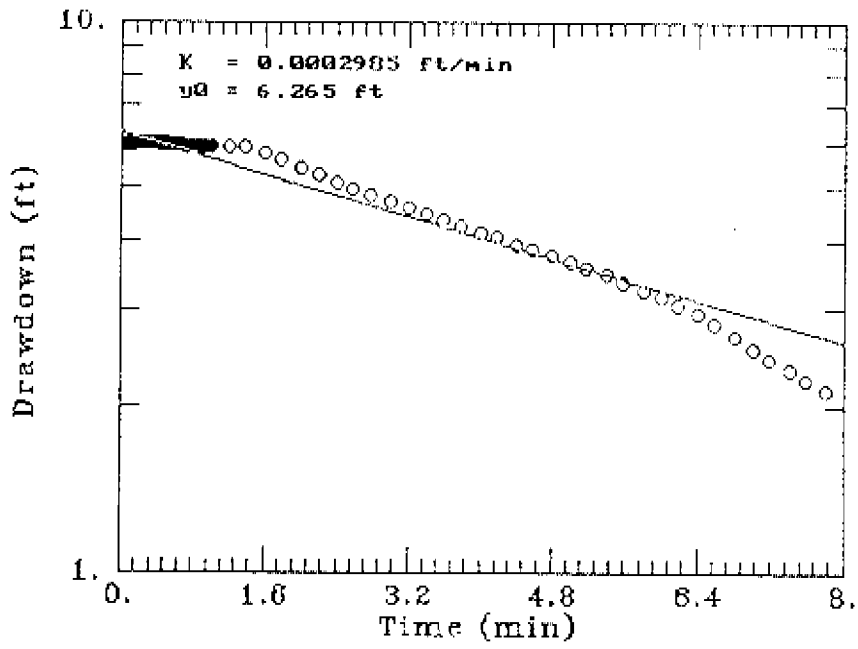

Figure D-21. Analyses of Slug Test for P12A

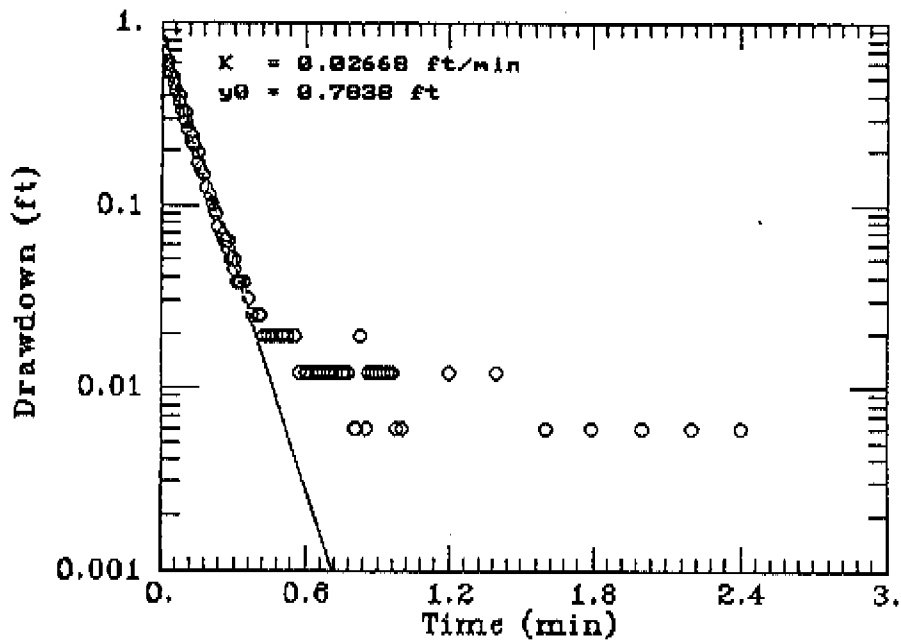

Figure D-22. Analyses of Slug Test for P12B

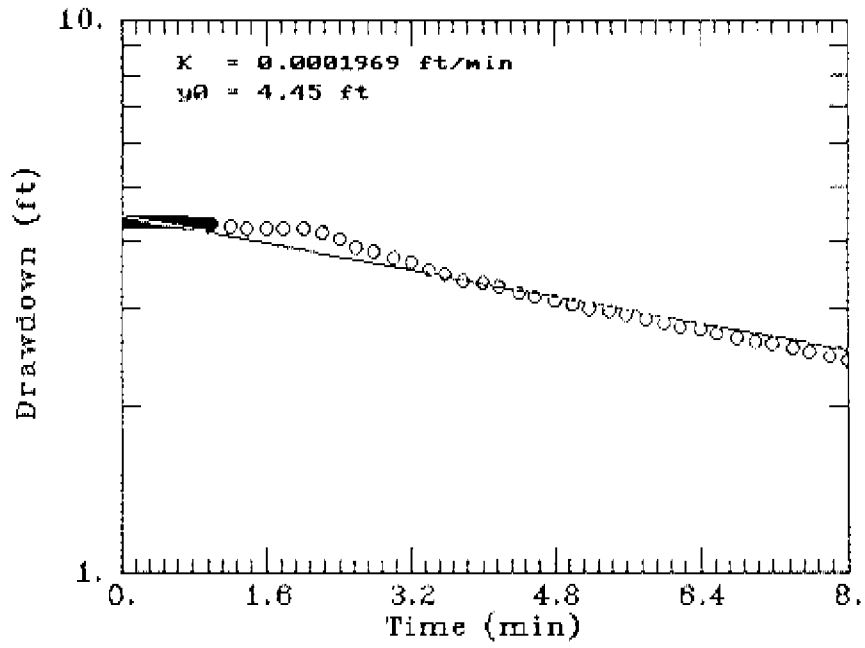

Figure D-23. Analyses of Slug Test for P13A

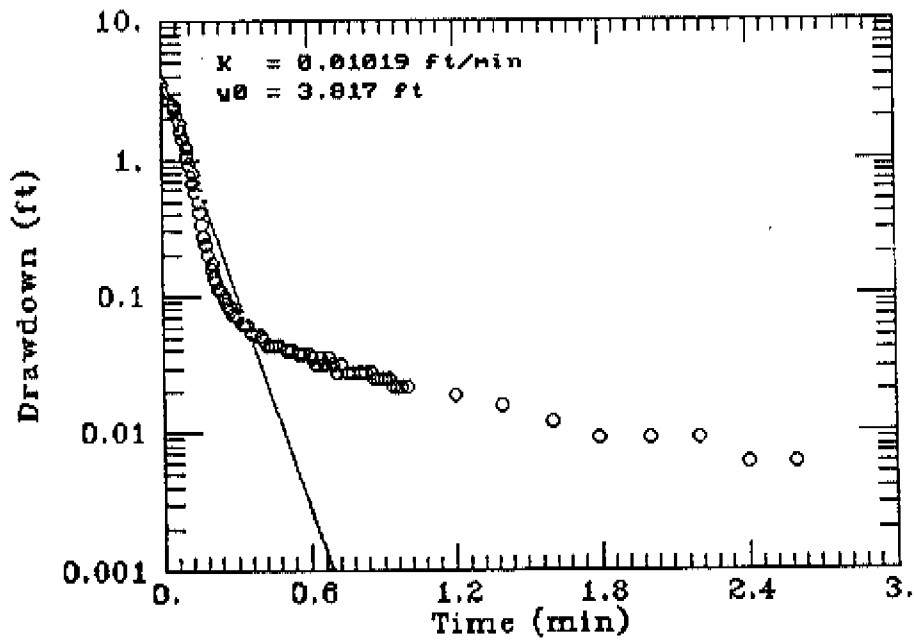

Figure D-24. Analyses of Slug Test for P13B

SE2000		0.2666	0.330	2.600	0.006
Environmental Logger		0.2833	0.304	3.000	0.012
10/26/98 15:13		0.2916	0.292	3.200	0.012
		0.3000	0.272		
Unit# TESTOHP Test 2		0.3083	0.266		
		0.3166	0.253		
Setups:	INPUT 1	0.3250	0.241		
-----	-----	0.3333	0.234		
Type	Level (F)	0.3500	0.209		
Mode	TOC	0.3666	0.190		
ID	ENRP02B	0.3833	0.184		
		0.4000	0.171		
Reference	0	0.4166	0.152		
SG	1	0.4333	0.139		
Linearity	0.095	0.4500	0.126		
Scale factor	20.056	0.4666	0.114		
Offset	0.002	0.4833	0.107		
Delay MSEC	50	0.5000	0.095		
		0.5166	0.088		
Step 0 10/25	12:41:19	0.5333	0.082		
		0.5500	0.076		
Elapsed Time	INPUT 1	0.5666	0.063		
-----	-----	0.5833	0.063		
0	1.2060	0.6000	0.057		
0.0083	1.1610	0.6166	0.057		
0.0166	1.1170	0.6333	0.050		
0.0250	1.0790	0.6500	0.050		
0.0333	1.0340	0.6666	0.044		
0.0416	0.9960	0.6833	0.038		
0.0500	0.9580	0.7000	0.038		
0.0583	0.9260	0.7166	0.038		
0.0666	0.8880	0.7333	0.038		
0.0750	0.8500	0.7500	0.025		
0.0833	0.8180	0.7666	0.025		
0.0916	0.7930	0.7833	0.025		
0.1000	0.7610	0.8000	0.019		
0.1083	0.7230	0.8166	0.025		
0.1166	0.7040	0.8333	0.025		
0.1250	0.6720	0.8500	0.025		
0.1333	0.6470	0.8666	0.019		
0.1416	0.6220	0.8833	0.019		
0.1500	0.5900	0.9000	0.019		
0.1583	0.5710	0.9166	0.019		
0.1666	0.5520	0.9333	0.019		
0.1750	0.5260	0.9500	0.019		
0.1833	0.5070	0.9666	0.012		
0.1916	0.4820	0.9833	0.012		
0.2000	0.4690	1.0000	0.012		
0.2083	0.4440	1.2000	0.012		
0.2166	0.4190	1.4000	0.006		
0.2250	0.4060	1.6000	0.006		
0.2333	0.3930	1.8000	0.006		
0.2416	0.3740	2.0000	0.012		
0.2500	0.3550	2.2000	0.012		
0.2583	0.3490	2.4000	0.006		

		0.2666	0.0120	2.600	0.006
	SE2000	0.2750	0.0120	2.800	0.006
	Environmental Logger	0.2833	0.0120	3.000	0.012
	10/26/98 15:17	0.2916	0.0120	3.200	0.006
		0.3000	0.0120	3.400	0.012
	Unit# TESTOHP test 4	0.3083	0.0120	3.600	0.006
		0.3166	0.0120	3.800	0.012
Setups:	INPUT 1	0.3250	0.0120	4.000	0.006
-----	-----	0.3333	0.0120	4.200	0.006
Type	Level (F)	0.3500	0.0120	4.400	0.006
Mode	TOC	0.3666	0.0120	4.600	0.006
I.D.	ENRP03A	0.3833	0.0120	4.800	0.006
		0.4000	0.0120	5.000	0.006
Reference	0	0.4166	0.0120		
SG	1	0.4333	0.0120		
Linearity	0.095	0.4500	0.0120		
Scale factor	20.056	0.4666	0.0120		
offset	0.002	0.4833	0.0060		
Delay MSEC	50	0.5000	0.0120		
		0.5166	0.0120		
Step 0 10/25	13:25:07	0.5333	0.0120		
		0.5500	0.0060		
	Elapsed Time	INPUT 1	0.5666	0.0060	
			0.5833	0.0120	
	0.0000	0.2470	0.6000	0.0120	
	0.0083	0.1840	0.6166	0.0060	
	0.0166	0.1390	0.6333	0.0060	
	0.0250	0.1140	0.6500	0.0060	
	0.0333	0.0820	0.6666	0.0120	
	0.0416	0.0630	0.6833	0.0120	
	0.0500	0.0500	0.7000	0.0060	
	0.0583	0.0380	0.7166	0.0120	
	0.0666	0.0310	0.7333	0.0120	
	0.0750	0.0250	0.7500	0.0120	
	0.0833	0.0250	0.7666	0.0120	
	0.0916	0.0190	0.7833	0.0120	
	0.1000	0.0190	0.8000	0.0060	
	0.1083	0.0120	0.8166	0.0120	
	0.1166	0.0190	0.8333	0.0120	
	0.1250	0.0120	0.8500	0.0060	
	0.1333	0.0120	0.8666	0.0120	
	0.1416	0.0120	0.8833	0.0120	
	0.1500	0.0120	0.9000	0.0060	
	0.1583	0.0120	0.9166	0.0060	
	0.1666	0.0120	0.9333	0.0120	
	0.1750	0.0120	0.9500	0.0120	
	0.1833	0.0120	0.9666	0.0120	
	0.1916	0.0060	0.9833	0.0060	
	0.2000	0.0190	1.0000	0.0060	
	0.2083	0.0120	1.2000	0.0120	
	0.2166	0.0120	1.4000	0.0120	
	0.2250	0.0120	1.6000	0.0060	
	0.2333	0.0120	1.8000	0.0060	
	0.2416	0.0190	2.0000	0.0120	
	0.2500	0.0120	2.2000	0.0060	
	0.2583	0.0120	2.4000	0.0060	

SE2000		2.600	0.601
Environmental Logger		3.000	0.588
10/28/98 16:45		3.200	0.578
		3.400	0.572
Unit# TEST01IPP Test 6		3.600	0.562
		3.800	0.549
Setups:	INPUT 1	4.000	0.510
-----	-----	4.200	0.530
Type	Level (F)	4.400	0.524
Mode	TOC	4.600	0.508
I.D.	ENRP04A	4.800	0.502
		5.000	0.489
Reference	0	5.200	0.482
SG	1	5.400	0.473
Linearity	0.036	5.600	0.466
Scale factor	10.106	5.800	0.454
offset	0.005	6.000	0.444
Delay MSEC	50	6.200	0.434
		6.400	0.425
Step 0 10/28	12:26:46	6.600	0.415
		6.800	0.409
Elapsed Time	INPUT 1	7.000	0.399
		7.200	0.390
0.0000	0.661	7.400	0.380
0.0083	0.661	7.600	0.374
0.0166	0.665	7.800	0.364
0.0250	0.661	8.000	0.354
0.0333	0.661	8.200	0.348
0.0416	0.661	8.400	0.342
0.0500	0.665	8.600	0.332
0.0583	0.661	8.800	0.326
0.0666	0.665	9.000	0.316
0.0750	0.661	9.200	0.310
0.0833	0.661	9.400	0.303
0.0916	0.661	9.600	0.300
0.1000	0.661	9.800	0.290
0.1083	0.658	10.000	0.281
0.1166	0.661	11.000	0.239
0.1250	0.658	12.000	0.204
0.1333	0.661		
0.1416	0.661		
0.1500	0.661		
0.1583	0.658		
0.1666	0.661		
0.1750	0.661		
0.1833	0.661		
0.1916	0.661		
0.2000	0.658		
0.2083	0.661		
0.2166	0.661		
0.2250	0.661		
0.2333	0.658		
0.2416	0.658		
0.2500	0.658		
0.2583	0.661		

			0.2666	0.578	2.600	0.038
SE2000			0.2750	0.559	2.800	0.038
Environmental Logger			0.2833	0.540	3.000	0.044
10/26/98 15:25			0.2916	0.521	3.200	0.038
			0.3000	0.502	3.400	0.038
Unit# TESTOHP Test 7			0.3083	0.489	3.600	0.038
			0.3166	0.470	3.800	0.038
Setups:	INPUT 1		0.3250	0.451	4.000	0.044
			0.3333	0.438	4.200	0.044
Type	Level (F)		0.3500	0.407	4.400	0.044
Mode	TOC		0.3666	0.381	4.600	0.044
I.D.	ENRP04B		0.3833	0.349	4.800	0.044
			0.4000	0.330	5.000	0.044
Reference	0		0.4166	0.305	5.200	0.044
SG	1		0.4333	0.286	5.400	0.044
Linearity	0.095		0.4500	0.273	5.600	0.044
Scale factor	20.056		0.4666	0.248	5.800	0.038
offset	0.002		0.4833	0.229	6.000	0.038
Delay MSEC	50		0.5000	0.222	6.200	0.038
			0.5166	0.203	6.400	0.038
Step 0 10/25	14:20:47		0.5333	0.190	6.600	0.038
			0.5500	0.178	6.800	0.038
Elapsed Time	INPUT 1		0.5666	0.171	7.000	0.038
			0.5833	0.159	7.200	0.038
0.0000	1.755		0.6000	0.139	7.400	0.044
0.0083	1.717		0.6166	0.139	7.600	0.038
0.0166	1.653		0.6333	0.133	7.800	0.038
0.0250	1.602		0.6500	0.120	8.000	0.038
0.0333	1.545		0.6666	0.114		
0.0416	1.488		0.6833	0.101		
0.0500	1.443		0.7000	0.101		
0.0583	1.399		0.7166	0.095		
0.0666	1.348		0.7333	0.089		
0.0750	1.297		0.7500	0.082		
0.0833	1.259		0.7666	0.082		
0.0916	1.221		0.7833	0.076		
0.1000	1.170		0.8000	0.076		
0.1083	1.138		0.8166	0.076		
0.1166	1.094		0.8333	0.069		
0.1250	1.062		0.8500	0.069		
0.1333	1.017		0.8666	0.063		
0.1416	0.985		0.8833	0.063		
0.1500	0.954		0.9000	0.057		
0.1583	0.922		0.9166	0.057		
0.1666	0.884		0.9333	0.063		
0.1750	0.858		0.9500	0.057		
0.1833	0.826		0.9666	0.057		
0.1916	0.795		0.9833	0.057		
0.2000	0.769		1.0000	0.057		
0.2083	0.744		1.2000	0.044		
0.2166	0.718		1.4000	0.044		
0.2250	0.693		1.6000	0.044		
0.2333	0.674		1.8000	0.044		
0.2416	0.642		1.0000	0.044		
0.2500	0.623		1.2000	0.038		
0.2583	0.597		1.4000	0.038		

	SE2000		0.2666	1.999	2.6000	0.340
	Environmental Logger		0.2750	1.987	2.8000	0.273
	10/26/98 15:30		0.2833	1.987	3.0000	0.222
			0.2916	1.987	3.2000	0.171
			0.3000	1.980	3.4000	0.114
	Unit# TESTOHPH Test	10	0.3083	1.968	3.6000	0.082
			0.3166	1.961	3.8000	0.063
Setups:	INPUT 1		0.3250	1.955	4.0000	0.063
-----	-----		0.3333	1.955	4.2000	0.057
Type	Level (F)		0.3500	1.942	4.4000	0.044
Mode	TOC		0.3666	1.930	4.6000	0.050
I.D.	ENRP05A		0.3833	1.917	4.8000	0.044
			0.4000	1.904	5.0000	0.031
Reference	0		0.4166	1.892	5.2000	0.031
SG	1		0.4333	1.879	5.4000	0.019
Linearity	0.095		0.4500	1.866	5.6000	0.019
Scale factor	20.056		0.4666	1.853	5.8000	0.012
offset	0.002		0.4833	1.841	6.0000	0.025
Delay MSEC	50		0.5000	1.828	6.2000	0.019
			0.5166	1.809	6.4000	0.012
Step 0 10/25	15:24:01		0.5333	1.803	6.6000	0.000
			0.5500	1.784	6.8000	0.006
	Elapsed Time	INPUT 1	0.5666	1.765	7.0000	0.006
			0.5833	1.752		
	0.0000	2.107	0.6000	1.733		
	0.0083	2.107	0.6166	1.720		
	0.0166	2.095	0.6333	1.701		
	0.0250	2.107	0.6500	1.688		
	0.0333	2.101	0.6666	1.676		
	0.0416	2.101	0.6833	1.663		
	0.0500	2.101	0.7000	1.650		
	0.0583	2.088	0.7166	1.638		
	0.0666	2.095	0.7333	1.612		
	0.0750	2.095	0.7500	1.593		
	0.0833	2.088	0.7666	1.555		
	0.0916	2.088	0.7833	1.536		
	0.1000	2.076	0.8000	1.511		
	0.1083	2.076	0.8166	1.498		
	0.1166	2.076	0.8333	1.479		
	0.1250	2.076	0.8500	1.460		
	0.1333	2.069	0.8666	1.441		
	0.1416	2.063	0.8833	1.428		
	0.1500	2.063	0.9000	1.415		
	0.1583	2.050	0.9166	1.396		
	0.1666	2.050	0.9333	1.384		
	0.1750	2.044	0.9500	1.358		
	0.1833	2.044	0.9666	1.346		
	0.1916	2.038	0.9833	1.333		
	0.2000	2.031	1.0000	1.314		
	0.2083	2.031	1.2000	1.130		
	0.2166	2.025	1.4000	0.971		
	0.2250	2.025	1.6000	0.831		
	0.2333	2.019	1.8000	0.704		
	0.2416	2.012	2.0000	0.590		
	0.2500	2.006	2.2000	0.501		
	0.2583	2.006	2.4000	0.419		

			0.2666	0.022
	SE2000		0.2750	0.022
	Environmental Logger		0.2833	0.022
	10/28/98 16:40		0.2916	0.025
			0.3000	0.025
	Unitt TESTOHP Test 4		0.3083	0.022
			0.3166	0.025
Setups:	INPUT 1		0.3250	0.025
-----	-----		0.3333	0.025
Type	Level (F)		0.3500	0.025
Mode	TOC		0.3666	0.025
I.D.	ENRP05B		0.3833	0.025
			0.4000	0.028
Reference	0		0.4166	0.028
SG	1		0.4333	0.028
Linearity	0.036		0.4500	0.028
Scale fact	10.106		0.4666	0.028
Offset	0.005		0.4833	0.028
Delay MSE	50		0.5000	0.028
			0.5166	0.028
Step 0 10/	11:57:49		0.5333	0.028
			0.5500	0.028
	Elapsed Time	INPUT 1	0.5666	0.028
	-----	-----	0.5833	0.028
	0.0000	0.914	0.6000	0.025
	0.0083	0.670	0.6166	0.028
	0.0166	0.561	0.6333	0.025
	0.0250	0.545	0.6500	0.028
	0.0333	0.542	0.6666	0.025
	0.0416	0.465	0.6833	0.025
	0.0500	0.385	0.7000	0.025
	0.0583	0.349	0.7166	0.025
	0.0666	0.279	0.7333	0.025
	0.0750	0.205	0.7500	0.025
	0.0833	0.102	0.7666	0.022
	0.0916	0.035	0.7833	0.025
	0.1000	-0.009	0.8000	0.025
	0.1083	-0.028	0.8166	0.022
	0.1166	-0.019	0.8333	0.025
	0.1250	-0.006	0.8500	0.022
	0.1333	0.009	0.8666	0.025
	0.1416	0.016	0.8833	0.025
	0.1500	0.022	0.9000	0.025
	0.1583	0.022	0.9166	0.025
	0.1666	0.016	0.9333	0.022
	0.1750	0.016	0.9500	0.025
	0.1833	0.003	0.9666	0.025
	0.1916	0.003	0.9833	0.022
	0.2000	0.009	1.0000	0.022
	0.2083	0.012	1.2000	0.022
	0.2166	0.022	1.4000	0.022
	0.2250	0.022	1.6000	0.019
	0.2333	0.025	1.8000	0.019
	0.2416	0.025	2.0000	0.019
	0.2500	0.025	2.2000	0.019
	0.2583	0.022	2.4000	0.019
			2.6000	0.019

			0.2666	2.379	2.6000
	SE2000		0.2750	2.376	2.8000
	Environmental Logger		0.2833	2.370	3.0000
	10/28/98 16:36		0.2916	2.367	3.2000
			0.3000	2.360	
	Unit: TES (OHPP Test 2		0.3083	2.354	
			0.3166	2.351	
Setups:	INPUT 1		0.3250	2.341	
-----	-----		0.3333	2.335	
Type	Level (Γ)		0.3500	2.319	
Mode	TOC		0.3666	2.299	
I.D.	ENRPO6A		0.3833	2.283	
			0.4000	2.274	
Reference	0		0.4166	2.261	
SG	1		0.4333	2.255	
Linearity	0.036		0.4500	2.239	
Scale factor	10.106		0.4666	2.223	
Offset	0.005		0.4833	2.213	
Delay MSEC	50		0.5000	2.194	
			0.5166	2.175	
Step 0 10/28	11:27:28		0.5333	2.159	
			0.5500	2.139	
	Elapsed Time	INPUT 1	0.5666	2.127	
	-----	-----	0.5833	2.111	
	0.0000	3.111	0.6000	1.980	
	0.0083	3.108	0.6166	1.976	
	0.0166	3.099	0.6333	1.896	
	0.0250	3.086	0.6500	1.884	
	0.0333	3.054	0.6666	1.868	
	0.0416	3.000	0.6833	1.855	
	0.0500	2.936	0.7000	1.842	
	0.0583	2.872	0.7166	1.730	
	0.0666	2.817	0.7333	1.721	
	0.0750	2.753	0.7500	1.708	
	0.0833	2.686	0.7666	1.698	
	0.0916	2.673	0.7833	1.689	
	0.1000	2.629	0.8000	1.679	
	0.1083	2.581	0.8166	1.673	
	0.1166	2.565	0.8333	1.663	
	0.1250	2.558	0.8500	1.551	
	0.1333	2.514	0.8666	1.538	
	0.1416	2.485	0.8833	1.529	
	0.1500	2.466	0.9000	1.516	
	0.1583	2.456	0.9166	1.503	
	0.1666	2.443	0.9333	1.490	
	0.1750	2.437	0.9500	1.477	
	0.1833	2.437	0.9666	1.465	
	0.1916	2.430	0.9833	1.455	
	0.2000	2.421	1.0000	1.442	
	0.2083	2.414	1.2000	1.282	
	0.2166	2.408	1.4000	1.033	
	0.2250	2.405	1.6000	0.585	
	0.2333	2.398	1.8000	0.377	
	0.2416	2.395	2.0000	0.284	
	0.2500	2.389	2.2000	0.230	
	0.2583	2.386	2.4000	0.185	

	SE2000		0.2666	3.155
	Environmental Logger		0.2750	3.116
	10/28/98 16:38		0.2833	3.075
	Unit/ TESTOHP Test 3		0.2916	3.036
			0.3000	2.998
			0.3083	2.959
Setups:	INPUT 1		0.3166	2.921
			0.3250	2.886
Type	Level (F)		0.3333	2.847
Mode	TOC		0.3500	2.777
I.D.	ENRPO6B		0.3666	2.710
			0.3833	2.639
Reference	0		0.4000	2.575
SG	1		0.4166	2.511
Linearity	0.036		0.4333	2.450
Scale factor	10.106		0.4500	2.389
Offset	0.005		0.4666	2.332
Delay MSEC	50		0.4833	2.274
			0.5000	2.217
Step 0 10/28	11:39:10		0.5166	2.165
			0.5333	2.111
	Elapsed Time	INPUT 1	0.5500	2.053
			0.5666	2.005
	0.0000	5.146	0.5833	1.954
	0.0083	5.069	0.6000	1.903
	0.0166	4.986	0.6166	1.855
	0.0250	4.906	0.6333	1.807
	0.0333	4.823	0.6500	1.762
	0.0416	4.736	0.6666	1.714
	0.0500	4.659	0.6833	1.669
	0.0583	4.576	0.7000	1.627
	0.0666	4.509	0.7166	1.586
	0.0750	4.438	0.7333	1.541
	0.0833	4.368	0.7500	1.502
	0.0916	4.291	0.7666	1.461
	0.1000	4.221	0.7833	1.422
	0.1083	4.154	0.8000	1.387
	0.1166	4.083	0.8166	1.348
	0.1250	4.013	0.8333	1.310
	0.1333	3.933	0.8500	1.275
	0.1416	3.869	0.8666	1.243
	0.1500	3.785	0.8833	1.208
	0.1583	3.757	0.9000	1.175
	0.1666	3.696	0.9166	1.143
	0.1750	3.629	0.9333	1.115
	0.1833	3.590	0.9500	1.079
	0.1916	3.545	0.9666	1.054
	0.2000	3.497	0.9833	1.025
	0.2083	3.453	1.0000	0.996
	0.2166	3.408	1.2000	0.685
	0.2250	3.363	1.4000	0.487
	0.2333	3.318	1.6000	0.336
	0.2416	3.276	1.8000	0.230
	0.2500	3.235		
	0.2583	3.193		

	SE2000		0.2666	0.655	0.2666	0.882	2.6000	0.590
	Environmental Logger		0.2833	0.658	0.2833	0.869	3.0000	0.584
	10/26/98 15:46		0.2916	0.658	0.2916	0.857	3.2000	0.590
	Unit# TESTOHPP Test 18		0.3000	0.661	0.3000	0.857	3.4000	0.590
			0.3083	0.658	0.3083	0.850	3.6000	0.590
Setups:	INPUT 1		0.3166	0.655	0.3166	0.844	3.8000	0.584
			0.3250	0.658	0.3250	0.838	4.0000	0.584
Type	Level (F)		0.3333	0.658	0.3233	0.825	4.2000	0.590
Mode	TOC		0.3500	0.655	0.3500	0.819	4.4000	0.590
I.D.	ENRP07A		0.3666	0.658	0.3666	0.806	4.6000	0.590
			0.3833	0.658	0.3833	0.793	4.8000	0.590
Reference	0		0.4000	0.658	0.4000	0.780	5.0000	0.590
SG	1		0.4166	0.655	0.4166	0.774	5.2000	0.590
Linearity	0.095		0.4333	0.655	0.4333	0.755	5.4000	0.584
Scale factor	20.056		0.4500	0.655	0.4500	0.749	5.6000	0.590
offset	0.002		0.4666	0.655	0.4666	0.736	5.8000	0.590
Delay MSEC	50		0.4833	0.658	0.4833	0.723	6.0000	0.584
			0.5000	0.655	0.5000	0.717	6.2000	0.590
Step 0 10/26	13:16:37		0.5166	0.655	0.5166	0.711	6.4000	0.590
			0.5333	0.655	0.5333	0.704	6.6000	0.590
	Elapsed Time	INPUT1	0.5500	0.652	0.5500	0.692	6.8000	0.590
			0.5666	0.652	0.5666	0.685		
	0.0000	0.996	0.5833	0.652	0.5833	0.679		
	0.0083	1.003	0.6000	0.652	0.6000	0.666		
	0.0166	0.996	0.6166	0.652	0.6166	0.666		
	0.0250	0.996	0.6333	0.652	0.6333	0.660		
	0.0333	0.996	0.6500	0.652	0.6500	0.653		
	0.0416	1.003	0.6666	0.649	0.6666	0.653		
	0.0500	0.996	0.6833	0.649	0.6833	0.641		
	0.0583	0.996	0.7000	0.652	0.7166	0.634		
	0.0666	0.996	0.7166	0.649	0.7166	0.634		
	0.0750	0.996	0.7333	0.649	0.7333	0.628		
	0.0833	0.990	0.7500	0.649	0.0750	0.622		
	0.0916	0.984	0.7666	0.649	0.7666	0.622		
	0.1000	0.990	0.7833	0.645	0.7833	0.615		
	0.1083	0.984	0.8000	0.649	0.8000	0.615		
	0.1166	0.984	0.8166	0.645	0.8166	0.615		
	0.1250	0.984	0.8333	0.645	0.8333	0.615		
	0.1333	0.977	0.8500	0.645	0.8500	0.609		
	0.1416	0.977	0.8666	0.645	0.9666	0.609		
	0.1500	0.965	0.8833	0.645	0.8833	0.609		
	0.1583	0.965	0.9000	0.645	0.9000	0.603		
	0.1666	0.958	0.9166	0.642	0.9166	0.603		
	0.1750	0.952	0.9333	0.639	0.9333	0.596		
	0.1833	0.945	0.9500	0.642	0.9500	0.603		
	0.1916	0.939	0.9666	0.642	0.9666	0.603		
	0.2000	0.939	0.9833	0.642	0.9833	0.596		
	0.2083	0.933	1.0000	0.642	1.0000	0.590		
	0.2166	0.920	1.2000	0.636	1.2000	0.584		
	0.2250	0.920	1.4000	0.629	1.4000	0.584		
	0.2333	0.907	1.6000	0.626	1.6000	0.590		
	0.2416	0.907	1.8000	0.620	1.8000	0.584		
	0.2500	0.901	2.0000	0.620	2.0000	0.590		
	0.2583	0.895	2.2000	0.613	2.2000	0.590		
			2.4000	0.604	2.4000	0.590		

		0.2666	0.655	0.2666	0.882	2.6000	0.59	
	SE2000	0.2750	0.661	0.2750	0.876	2.8000	0.59	
	Environmental Logger	0.2833	0.658	0.2833	0.869	3.0000	0.58	
	10/26/98 15:46	0.2916	0.658	0.2916	0.857	3.2000	0.59	
	Unit# TESTOHP Test 18	0.3000	0.661	0.3000	0.857	3.4000	0.59	
		0.3083	0.658	0.3083	0.850	3.6000	0.59	
Setups:	INPUT 1	0.3166	0.655	0.3166	0.844	3.8000	0.58	
		0.3250	0.658	0.3250	0.838	4.0000	0.58	
Type	Level (F)	0.3333	0.658	0.3233	0.825	4.2000	0.59	
Mode	TOC	0.3500	0.655	0.3500	0.819	4.4000	0.59	
I.D.	ENRP07A	0.3666	0.658	0.3666	0.806	4.6000	0.59	
		0.3833	0.658	0.3833	0.793	4.8000	0.59	
Reference	0	0.4000	0.658	0.4000	0.780	5.0000	0.59	
SG	1	0.4166	0.655	0.4166	0.774	5.2000	0.59	
Linearity	0.095	0.4333	0.655	0.4333	0.755	5.4000	0.58	
Scale fact	20.056	0.4500	0.655	0.4500	0.749	5.6000	0.59	
offset	0.002	0.4666	0.655	0.4666	0.736	5.8000	0.59	
Delay MSF	50	0.4833	0.658	0.4833	0.723	6.0000	0.58	
		0.5000	0.655	0.5000	0.717	6.2000	0.59	
Step 0 10/:	13:16:37	0.5166	0.655	0.5166	0.711	6.4000	0.59	
		0.5333	0.655	0.5333	0.704	6.6000	0.59	
	Elapsed Time	INPUT1	0.5500	0.652	0.5500	0.692	6.8000	0.59
			0.5666	0.652	0.5666	0.685		
	0.0000	0.996	0.5833	0.652	0.5833	0.679		
	0.0083	1.003	0.6000	0.652	0.6000	0.666		
	0.0166	0.996	0.6166	0.652	0.6166	0.666		
	0.0250	0.996	0.6333	0.652	0.6333	0.660		
	0.0333	0.996	0.6500	0.652	0.6500	0.653		
	0.0416	1.003	0.6666	0.649	0.6666	0.653		
	0.0500	0.996	0.6833	0.649	0.6833	0.641		
	0.0583	0.996	0.7000	0.652	0.7166	0.634		
	0.0666	0.996	0.7166	0.649	0.7166	0.634		
	0.0750	0.996	0.7333	0.649	0.7333	0.628		
	0.0833	0.990	0.7500	0.649	0.0750	0.622		
	0.0916	0.984	0.7666	0.649	0.7666	0.622		
	0.1000	0.990	0.7833	0.645	0.7833	0.615		
	0.1083	0.984	0.8000	0.649	0.8000	0.615		
	0.1166	0.984	0.8166	0.645	0.8166	0.615		
	0.1250	0.984	0.8333	0.645	0.8333	0.615		
	0.1333	0.977	0.8500	0.645	0.8500	0.609		
	0.1416	0.977	0.8666	0.645	0.9666	0.609		
	0.1500	0.965	0.8833	0.645	0.8833	0.609		
	0.1583	0.965	0.9000	0.645	0.9000	0.603		
	0.1666	0.958	0.9166	0.642	0.9166	0.603		
	0.1750	0.952	0.9333	0.639	0.9333	0.596		
	0.1833	0.945	0.9500	0.642	0.9500	0.603		
	0.1916	0.939	0.9666	0.642	9.6660	0.603		
	0.2000	0.939	0.9833	0.642	0.9833	0.596		
	0.2083	0.933	1.0000	0.642	1.0000	0.590		
	0.2166	0.920	1.2000	0.636	1.2000	0.584		
	0.2250	0.920	1.4000	0.629	1.4000	0.584		
	0.2333	0.907	1.6000	0.626	1.6000	0.590		
	0.2416	0.907	1.8000	0.620	1.8000	0.584		
	0.2500	0.901	2.0000	0.620	2.0000	0.590		
	0.2583	0.895	2.2000	0.613	2.2000	0.590		
			2.4000	0.604	2.4000	0.590		

Environmental Logger		0.2666	-0.028
10/28/98 16:32		0.2750	-0.044
		0.2833	-0.048
		0.2916	-0.048
Uniti TESTOHPP Test 1		0.3000	-0.044
		0.3083	-0.038
Setups:	INPUT 1	0.3166	-0.032
-----	-----	0.3250	-0.032
Type	Level (F)	0.3333	-0.032
Mode	TOC	0.3500	-0.038
I.D.	ENRP0/B	0.3666	-0.041
		0.3833	-0.038
Reference	0	0.4000	-0.035
SG	1	0.4166	-0.038
Linearity	0.036	0.4333	-0.038
Scale factor	10.106	0.4500	-0.041
Offset	0.005	0.4666	-0.038
Delay MSEC	50	0.4833	-0.038
		0.5000	-0.038
Step 0 10/28 10:58:24		0.5166	-0.039
		0.5333	-0.038
	Elapsed Time INPUT 1	0.5500	-0.038
	-----	0.5666	-0.038
	0.0000 0.408	0.5833	-0.038
	0.0083 0.401	0.6000	-0.038
	0.0166 0.392	0.6166	0.038
	0.0250 0.382	0.6333	-0.038
	0.0333 0.369	0.6500	-0.038
	0.0416 0.347	0.6666	-0.038
	0.0500 0.318	0.6833	-0.038
	0.0583 0.286	0.7000	-0.038
	0.0666 0.247	0.7166	-0.041
	0.0750 0.208	0.7333	-0.038
	0.0833 0.183	0.7500	-0.038
	0.0916 0.167	0.7666	-0.038
	0.1000 0.154	0.7833	-0.041
	0.1083 0.151	0.8000	-0.038
	0.1166 0.147	0.8166	-0.038
	0.1250 0.141	0.8333	-0.038
	0.1333 0.125	0.8500	-0.038
	0.1416 0.102	0.8666	-0.038
	0.1500 0.080	0.8833	-0.038
	0.1583 0.061	0.9000	-0.038
	0.1666 0.044	0.9166	-0.038
	0.1750 0.035	0.9333	-0.041
	0.1833 0.022	0.9500	-0.038
	0.1916 -0.003	0.9666	-0.038
	0.2000 -0.051	0.9833	-0.038
	0.2083 -0.083	1.0000	-0.038
	0.2166 -0.086	1.2000	-0.038
	0.2250 -0.057	1.4000	-0.038
	0.2333 -0.035		
	0.2416 -0.019		
	0.2500 -0.016		
	0.2583 -0.019		

			0.2666	2.991	2.6000	0.292
	SE2000		0.2750	2.985	2.8000	0.222
	Environmental Logger		0.2833	2.972	3.0000	0.171
	10/26/98 15:44		0.2916	2.966	3.2000	0.139
			0.3000	2.953	3.4000	0.114
	Unit# TESTQHPP Test 17		0.3083	2.940	3.6000	0.101
			0.3166	2.928	3.8000	0.088
	Setups:	INPUT 1	0.3250	2.921	4.0000	0.082
	-----	-----	0.3333	2.909	4.2000	0.069
Type	Level (F)		0.3500	2.889	4.4000	0.063
Mode	TOC		0.3666	2.864	4.6000	0.063
I.D.	ENRP10A		0.3833	2.845		
Reference	0		0.4000	2.813		
			0.4166	2.794		
SG	1		0.4333	2.775		
Linearity	0.095		0.4500	2.750		
Scale factor	20.056		0.4666	2.724		
offset	0.002		0.4833	2.693		
Delay MSEC	50		0.5000	2.667		
Step 0 10/26	12:53:55		0.5166	2.642		
			0.5333	2.616		
	Elapsed Time	INPUT 1	0.5500	2.591		
			0.5666	2.566		
			0.5833	2.547		
	0.0000	3.131	0.6000	2.521		
	0.0083	3.131	0.6166	2.489		
	0.0166	3.131	0.6333	2.464		
	0.0250	3.131	0.6500	2.439		
	0.0333	3.131	0.6666	2.413		
	0.0416	3.124	0.6833	2.381		
	0.0500	3.124	0.7000	2.362		
	0.0583	3.131	0.7166	2.331		
	0.0666	3.124	0.7333	2.299		
	0.0750	3.131	0.7500	2.274		
	0.0833	3.124	0.7666	2.242		
	0.0916	3.118	0.7833	2.216		
	0.1000	3.124	0.8000	2.185		
	0.1083	3.124	0.8166	2.159		
	0.1166	3.118	0.8333	2.134		
	0.1250	3.118	0.8500	2.102		
	0.1333	3.112	0.8666	2.077		
	0.1416	3.099	0.8833	2.045		
	0.1500	3.099	0.9000	2.013		
	0.1583	3.099	0.9166	1.994		
	0.1666	3.086	0.9333	1.969		
	0.1750	3.080	0.9500	1.943		
	0.1833	3.074	0.9666	1.912		
	0.1916	3.061	0.9833	1.886		
	0.2000	3.055	1.0000	1.854		
	0.2083	3.048	1.2000	1.543		
	0.2166	3.042	1.4000	1.276		
	0.2250	3.029	1.6000	1.041		
	0.2333	3.023	1.8000	0.806		
	0.2416	3.016	2.0000	0.660		
	0.2500	3.004	2.2000	0.514		
	0.2583	2.997	2.4000	0.393		

	SE2000		0.2666	0.069
	Environmental Logger		0.2833	0.057
	10/26/98 15:42		0.2916	0.057
			0.3000	0.044
	Unit# TESTOHP Test	16	0.3083	0.044
			0.3166	0.044
Setups:	INPUT 1		0.3250	0.038
-----	-----		0.3333	0.031
Type	Level (F)		0.3500	0.025
Mode	TOC		0.3666	0.025
I.D.	ENRP10B		0.3833	0.019
			0.4000	0.019
Reference	0		0.4166	0.012
SG	1		0.4333	0.006
Linearity	0.095		0.4500	0.012
Scale factor	20.056		0.4666	0.012
Offset	0.002		0.4833	0.012
Delay MSEC	50		0.5000	0.006
Step 0 10/26	12:44:34		0.5166	0.000
			0.5333	0.000
	Elapsed time	INPUT 1	0.5500	0.000
			0.5666	0.000
			0.5833	0.000
	0.0000	0.858	0.6000	0.000
	0.0083	0.820	0.6166	-0.006
	0.0166	0.783	0.6333	0.000
	0.0250	0.705	0.6500	-0.006
	0.0333	0.661	0.6666	0.000
	0.0416	0.616	0.6833	0.000
	0.0500	0.565	0.7000	0.000
	0.0583	0.527	0.7166	0.000
	0.0666	0.489	0.7333	-0.006
	0.0750	0.457	0.7500	0.000
	0.0833	0.426	0.7666	0.000
	0.0916	0.394	0.7833	-0.006
	0.1000	0.362	0.8000	0.000
	0.1083	0.337	0.8166	0.000
	0.1166	0.311	0.8333	0.000
	0.1250	0.286	0.8500	0.000
	0.1333	0.267	0.8666	0.000
	0.1416	0.247	0.8833	0.000
	0.1500	0.222	0.9000	0.000
	0.1583	0.209	0.9166	0.000
	0.1666	0.190	0.9333	0.000
	0.1750	0.171	0.9500	0.000
	0.1833	0.165	0.9666	-0.006
	0.1916	0.152	0.9833	0.000
	0.2000	0.139	1.0000	-0.006
	0.2083	0.127	1.2000	0.000
	0.2166	0.120	1.4000	0.000
	0.2250	0.108	1.6000	-0.006
	0.2333	0.101	1.8000	-0.006
	0.2416	0.089	2.0000	0.000
	0.2500	0.076	2.2000	0.000
	0.2583	0.076	2.4000	0.000

			0.2666	6.190
	SE2000		0.2750	6.180
	Environmental Logger		0.2833	6.186
	10/28/98 16:49		0.2916	6.158
			0.3000	6.129
	Unit/ TESTOHP Test	9	0.3083	6.113
			0.3166	6.116
Setups:	INPUT 1		0.3250	6.110
			0.3333	6.087
Type	Level (F)		0.3500	6.068
Mode	TOC		0.3666	6.058
I.D.	ENRP11A		0.3833	6.049
			0.4000	6.046
Reference	0		0.4166	6.042
SG	1		0.4333	6.039
Linearity	0.036		0.4500	6.036
Scale factor	10.106		0.4666	6.036
offset	0.005		0.4833	6.030
Delay MSEC	50		0.5000	6.030
			0.5166	6.026
Step 0 10/28	13:28:50		0.5333	6.023
			0.5500	6.023
	Elapsed Time	INPUT 1	0.5666	6.023
			0.5833	6.017
	0.0000	6.353	0.6000	6.017
	0.0083	6.353	0.6166	6.017
	0.0166	6.353	0.6333	6.011
	0.0250	6.353	0.6500	6.014
	0.0333	6.353	0.6666	6.014
	0.0416	6.349	0.6833	6.011
	0.0500	6.353	0.7000	6.011
	0.0583	6.353	0.7166	6.007
	0.0666	6.353	0.7333	6.004
	0.0750	6.349	0.7500	6.004
	0.0833	6.353	0.7666	6.004
	0.0916	6.353	0.7833	6.001
	0.1000	6.349	0.8000	6.001
	0.1083	6.353	0.8166	5.998
	0.1166	6.353	0.8333	5.998
	0.1250	6.356	0.8500	5.998
	0.1333	6.349	0.8666	5.995
	0.1416	6.349	0.8833	5.991
	0.1500	6.349	0.9000	5.995
	0.1583	6.346	0.9166	5.991
	0.1666	6.343	0.9333	5.988
	0.1750	6.346	0.9500	5.988
	0.1833	6.340	0.9666	5.985
	0.1916	6.337	0.9833	5.985
	0.2000	6.330	1.0000	5.985
	0.2083	6.321	1.2000	5.969
	0.2166	6.311	1.4000	5.956
	0.2250	6.292	1.6000	5.943
	0.2333	6.270	1.8000	5.927
	0.2416	6.244	2.0000	5.915
	0.2500	6.218	2.2000	5.902
	0.2583	6.190	2.4000	5.892

			0.2666	0.006
	SE2000		0.2750	0.006
	Environmental Logger		0.2833	0.006
	10/26/98 15:33		0.2916	0.000
			0.3000	0.000
	Unit# TESTOHPP Test 11		0.3083	0.006
			0.3166	0.006
Setups:	INPUT 1		0.3250	0.000
-----	-----		0.3333	0.000
Type	Level (F)		0.3500	0.006
Mode	TOC		0.3666	0.000
I.D.	ENRP11B		0.3833	0.000
			0.4000	0.006
Reference	0		0.4166	0.006
SG	1		0.4333	0.006
Linearity	0.095		0.4500	0.006
Scale factor	20.056		0.4666	0.006
Offset	0.002		0.4833	0.000
Delay MSFC	50		0.5000	0.006
			0.5166	0.000
Step 0 10/26	10:41:32		0.5333	0.000
			0.5500	0.000
	Elapsed Time	INPUT 1	0.5666	0.000
	-----	-----	0.5833	0.006
	0.0000	0.235	0.6000	0.000
	0.0083	0.203	0.6166	0.000
	0.0166	0.152	0.6333	0.000
	0.0250	0.108	0.6500	0.000
	0.0333	0.070	0.6666	0.000
	0.0416	0.044	0.6833	0.006
	0.0500	0.025	0.7000	0.006
	0.0583	0.019	0.7166	0.000
	0.0666	0.012	0.7333	0.006
	0.0750	0.006	0.7500	0.006
	0.0833	0.006	0.7666	0.000
	0.0916	0.006	0.7833	0.006
	0.1000	0.006	0.8000	0.000
	0.1083	0.006	0.8166	0.006
	0.1166	0.006	0.8333	0.000
	0.1250	0.006	0.8500	0.000
	0.1333	0.000	0.8666	0.000
	0.1416	0.006	0.8833	0.000
	0.1500	0.006	0.9000	0.000
	0.1583	0.000	0.9166	0.000
	0.1666	0.006	0.9333	0.000
	0.1750	0.006	0.9500	0.000
	0.1833	0.000	0.9666	0.006
	0.1916	0.006	0.9833	0.000
	0.2000	0.006	1.0000	0.000
	0.2083	0.006	1.2000	0.006
	0.2166	0.000	1.4000	0.000
	0.2250	0.006	1.6000	-0.101
	0.2333	0.006		
	0.2416	0.006		
	0.2500	0.006		
	0.2583	0.006		

SE2000		0.2666	5.992	2.6000	4.977	
Environmental Logger		0.2750	5.986	2.8000	4.837	
10/26/98 15:38		0.2833	5.992	3.0000	4.711	
		0.2916	5.992	3.2000	4.577	
Unit# TESTOHP Test 14		0.3000	5.992	3.4000	4.457	
		0.3083	5.992	3.6000	4.349	
Setups:	INPUT 1	0.3166	5.992	3.8000	4.235	
		0.3250	5.992	4.0000	4.146	
Type	Level (F)	0.3333	5.986	4.2000	4.050	
Mode	TOC	0.3500	5.992	4.4000	3.943	
I.D.	ENRP12A	0.3666	5.986	4.6000	3.847	
		0.3833	5.992	4.8000	3.746	
Reference	0	0.4000	5.992	5.0000	3.651	
SG	1	0.4166	5.986	5.2000	3.555	
Linearity	0.095	0.4333	5.980	5.4000	3.467	
Scale factor	20.056	0.4500	5.986	5.6000	3.359	
Offset	0.002	0.4666	5.980	5.8000	3.251	
Delay MSEC	50	0.4833	5.980	6.0000	3.149	
		0.5000	5.986	6.2000	3.048	
Step 0 10/26	12:10:20	0.5166	5.980	6.4000	2.952	
		0.5333	5.973	6.6000	2.832	
	Elapsed Time	INPUT 1	0.5500	5.967	6.8000	2.686
			0.5666	5.967	7.0000	2.546
	0.0000	5.973	0.5833	5.967	7.2000	2.438
	0.0083	5.980	0.6000	5.961	7.4000	2.324
	0.0166	5.980	0.6166	5.954	7.6000	2.229
	0.0250	5.973	0.6333	0.867	7.8000	2.140
	0.0333	5.973	0.6500	5.948		
	0.0416	5.980	0.6666	5.941		
	0.0500	5.980	0.6833	5.935		
	0.0583	5.980	0.7000	5.929		
	0.0666	5.980	0.7166	5.922		
	0.0750	5.980	0.7333	5.922		
	0.0833	5.980	0.7500	5.922		
	0.0916	5.980	0.7666	5.916		
	0.1000	5.986	0.7833	5.916		
	0.1083	5.980	0.8000	5.910		
	0.1166	5.986	0.8166	5.910		
	0.1250	5.980	0.8333	5.910		
	0.1333	5.986	0.8500	5.903		
	0.1416	5.980	0.8666	5.903		
	0.1500	5.980	0.8833	5.910		
	0.1583	5.986	0.9000	5.897		
	0.1666	5.986	0.9166	5.897		
	0.1750	5.986	0.9333	5.903		
	0.1833	5.986	0.9500	5.903		
	0.1916	5.986	0.9666	5.903		
	0.2000	5.992	0.9833	5.897		
	0.2083	5.992	1.0000	5.897		
	0.2166	5.986	1.2000	5.897		
	0.2250	5.992	1.4000	5.903		
	0.2333	5.992	1.6000	5.757		
	0.2416	5.992	1.8000	5.593		
	0.2500	5.986	2.0000	5.409		
	0.2583	5.986	2.2000	5.263		
			2.4000	5.117		

	SE2000		0.2666	0.063
	Environmental Logger		0.2833	0.057
	10/26/98 15:41		0.2916	0.050
			0.3000	0.050
	Unit# TESTOHPP Test	15	0.3083	0.044
			0.3166	0.038
Setups:	INPUT 1		0.3250	0.038
-----	-----		0.3333	0.038
Type	Level (F)		0.3500	0.038
Mode	TOC		0.3666	0.031
I.D.	ENRP12B		0.3833	0.025
			0.4000	0.025
Reference:	0		0.4166	0.025
SG	1		0.4333	0.019
Linearity	0.095		0.4500	0.019
Scale factor	20.056		0.4666	0.019
Offset	0.002		0.4833	0.019
Delay MSEC	50		0.5000	0.019
			0.5166	0.019
Step 0 10/26	12:26:10		0.5333	0.019
			0.5500	0.019
	Elapsed Time	INPUT 1	0.5666	0.019
	-----	-----	0.5833	0.012
	0.0000	0.775	0.6000	0.012
	0.0083	0.724	0.6166	0.012
	0.0166	0.667	0.6333	0.012
	0.0250	0.622	0.6500	0.012
	0.0333	0.578	0.6666	0.012
	0.0416	0.533	0.6833	0.012
	0.0500	0.495	0.7000	0.012
	0.0583	0.457	0.7166	0.012
	0.0666	0.425	0.7333	0.012
	0.0750	0.394	0.7500	0.012
	0.0833	0.362	0.7666	0.012
	0.0916	0.330	0.7833	0.012
	0.1000	0.317	0.8000	0.006
	0.1083	0.286	0.8166	0.006
	0.1166	0.260	0.8333	0.019
	0.1250	0.241	0.8500	0.006
	0.1333	0.222	0.8666	0.012
	0.1416	0.209	0.8833	0.012
	0.1500	0.197	0.9000	0.012
	0.1583	0.171	0.9166	0.012
	0.1666	0.158	0.9333	0.012
	0.1750	0.152	0.9500	0.012
	0.1833	0.146	0.9666	0.012
	0.1916	0.127	0.9833	0.006
	0.2000	0.114	1.0000	0.006
	0.2083	0.114	1.2000	0.012
	0.2166	0.101	1.4000	0.012
	0.2250	0.095	1.6000	0.006
	0.2333	0.089	1.8000	0.006
	0.2416	0.076	2.0000	0.006
	0.2500	0.069	2.2000	0.006
	0.2583	0.069	2.4000	0.006

			0.2666	4.309
	SE2000		0.2750	4.315
	Environmental Logger		0.2833	4.309
	10/26/98 15:11		0.2916	4.309
			0.3000	4.315
	Unit# TESTOHP Test	1	0.3083	4.315
			0.3166	4.309
Setups:	INPUT 1		0.3250	4.309
	-----		0.3333	4.309
Type	Level (F)		0.3500	4.309
Mode	TOC		0.3666	4.315
I.D.	ENRP13A		0.3833	4.309
			0.4000	4.309
Reference	0		0.4166	4.309
SG	1		0.4333	4.309
Linearity	0.095		0.4500	4.309
Scale factor	20.056		0.4666	4.309
offset	0.002		0.4833	4.309
Delay MSEC	50		0.5000	4.315
			0.5166	4.315
Step 0 10/25	11:33:09		0.5333	4.315
			0.5500	4.309
	Elapsed Time	INPUT 1	0.5666	4.315
	-----	-----	0.5833	4.315
	0.0000	4.309	0.6000	4.315
	0.0083	4.309	0.6166	4.309
	0.0166	4.309	0.6333	4.315
	0.0250	4.309	0.6500	4.309
	0.0333	4.309	0.6666	4.303
	0.0416	4.309	0.6833	4.303
	0.0500	4.315	0.7000	4.309
	0.0583	4.309	0.7166	4.296
	0.0666	4.303	0.7333	4.303
	0.0750	4.309	0.7500	4.296
	0.0833	4.309	0.7666	4.296
	0.0916	4.315	0.7833	4.296
	0.1000	4.309	0.8000	4.296
	0.1083	4.309	0.8166	4.296
	0.1166	4.309	0.8333	4.296
	0.1250	4.309	0.8500	4.290
	0.1333	4.309	0.8666	4.290
	0.1416	4.309	0.8833	4.290
	0.1500	4.309	0.9000	4.296
	0.1583	4.315	0.9166	4.290
	0.1666	4.309	0.9333	4.284
	0.1750	4.309	0.9500	4.284
	0.1833	4.309	0.9666	4.284
	0.1916	4.309	0.9833	4.277
	0.2000	4.309	1.0000	4.277
	0.2083	4.309	1.2000	4.252
	0.2166	4.309	1.4000	4.220
	0.2250	4.309	1.6000	4.214
	0.2333	4.315	1.8000	4.214
	0.2416	4.309	2.0000	4.195
	0.2500	4.309	2.2000	4.125
	0.2583	4.309	2.4000	4.030

	SE2000		0.2666	0.086
	Environmental Logger		0.2750	0.083
	10/28/98 16:53		0.2833	0.077
			0.2916	0.073
			0.3000	0.073
	Unit: f TESTOHP Test 12		0.3083	0.070
			0.3166	0.067
Setups:	INPUT 1		0.3250	0.064
-----	-----		0.3333	0.064
Type	Level (F)		0.3500	0.061
Mode	TOC		0.3666	0.054
I.D.	ENRP13B		0.3833	0.051
			0.4000	0.051
Reference	0		0.4166	0.048
SG	1		0.4333	0.044
Linearity	0.036		0.4500	0.044
Scale factor	10.106		0.4666	0.044
offset	0.005		0.4833	0.044
Delay MSEC	50		0.5000	0.041
			0.5166	0.041
Step 0 10/28	14:47:01		0.5333	0.041
			0.5500	0.038
	Elapsed Time	INPUT 1	0.5666	0.038
	-----	-----	0.5833	0.038
	0.0000	3.449	0.6000	0.038
	0.0083	3.073	0.6166	0.035
	0.0166	2.762	0.6333	0.032
	0.0250	2.714	0.6500	0.035
	0.0333	2.688	0.6666	0.032
	0.0416	2.585	0.6833	0.035
	0.0500	2.441	0.7000	0.032
	0.0583	2.306	0.7166	0.028
	0.0666	2.056	0.7333	0.032
	0.0750	1.808	0.7500	0.028
	0.0833	1.587	0.7666	0.028
	0.0916	1.391	0.7833	0.028
	0.1000	1.214	0.8000	0.028
	0.1083	1.060	0.8166	0.028
	0.1166	0.918	0.8333	0.028
	0.1250	0.790	0.8500	0.028
	0.1333	0.674	0.8666	0.025
	0.1416	0.578	0.8833	0.025
	0.1500	0.485	0.9000	0.025
	0.1583	0.414	0.9166	0.025
	0.1666	0.340	0.9333	0.025
	0.1750	0.273	0.9500	0.022
	0.1833	0.234	0.9666	0.022
	0.1916	0.199	0.9833	0.022
	0.2000	0.173	1.0000	0.022
	0.2083	0.154	1.2000	0.019
	0.2166	0.138	1.4000	0.016
	0.2250	0.128	1.6000	0.012
	0.2333	0.112	1.8000	0.009
	0.2416	0.109	2.0000	0.009
	0.2500	0.099	2.2000	0.009
	0.2583	0.093	2.4000	0.006
			2.6000	0.006

APPENDIX E: Ground Water Quality

Table E-1. Ground Water Quality at Station PO1B in the Everglades Nutrient Removal Project

STATION CODE	DATE	TEMP	D.O.	SP COND	PH	TURB	NOX	NO2	NH4	TKN	OP04	TP04	SI02	NA
	Mo/dayr	CENT.	MGL	UMF/OS/CM	UNITS	NTU	MG/NL	MG/NL	MG/NL	MG/NL	MG/PIL	MG/PIL	MG/L	MG/L
P01B	12/7/94	23.90		1285	6.90	29.00	0.01	0.00	1.98	3.82	0.015	0.029	27.10	122.50
P01B	3/7/95	22.90		1288	6.90	22.00	0.00	0.00	2.03	4.15	0.008	0.017	27.00	128.00
P01B	6/7/95	23.40		1319	7.21	6.10	0.02	0.00	1.56	3.83	0.006	0.021	26.00	120.50
P01B	9/6/95	23.50		1360	6.87	9.70	0.01	0.00	2.04	3.35	0.009	0.022	26.90	131.44
P01B	12/5/95	23.50	2.60	1303	6.76		0.00	0.00		4.11	0.007	0.057	27.90	126.00
P01B	3/6/96	23.20		1348	6.89	16.10	0.00	0.00	1.84	4.22	0.007	0.026	26.00	126.94
P01B	6/3/96	23.60	0.00	1334	7.02	2.40	-0.02	0.00	2.00	4.62	0.004	0.009	144.20	127.11
P01B	9/4/96	23.90	0.00	1314	6.94	2.90	-0.02	0.00	2.16	3.63	0.008	0.016	26.00	123.99
P01B	12/3/96	23.90	0.40	1346	7.03	16.20	0.01	0.00	2.82	5.14	0.012	0.027	28.40	115.00
P01B	3/4/97	23.40	0.10	1375	7.06	3.30	0.01	0.01	2.07	3.97	0.004	0.007	27.90	128.00
P01B	6/4/97	23.30	0.00	1348	7.03	8.70	0.00	0.00	2.02	4.97	-0.004	0.004	29.60	120.00
P01B	9/4/97	23.70	0.10	1299	6.69	2.00	0.01	0.01	1.92	4.74	0.006	0.013	25.60	150.00
P01B	12/2/97	23.50	1.30	1303	6.92									

STATION CODE	DATE	TEMP	CA	MG	CL	S04	HARDNESS	Sulfide	OXYPEDP	TOTAL AL	ALKALINITY	%SAT. DO	NO3
	Mo/dayr	MGL	MGL	M/HL	MGL	MGL	MG/L/CA/CO	MGL	M/LI/VOL	MG/ROG/L	MGL	PERCENT	MG/NL
P01B	12/7/94	5.80	101.00	36.15	148.10	42.10	401.00		-74.00	156.90	368.40		0.01
P01B	3/7/95	6.05	94.50	37.00	152.70	37.20	413.00		-97.00	28.40	362.40		0.00
P01B	6/7/95	6.35	98.50	36.00	150.50	40.10	364.00		-28.00	33.80	358.20		0.01
P01B	9/6/95	6.89	102.86	34.27	171.60	46.40	368.00		-48.00	23.19	378.70		0.01
P01B	12/5/95	7.04	107.53	34.32	168.20	42.20	410.00		-63.00	418.90		30.00	0.00
P01B	3/6/96	6.97	106.61	33.63	160.10	24.80	406.00		-56.00	153.90	368.40		-0.02
P01B	6/3/96	6.53	104.74	31.74	165.50	42.60	392.00		-383.00		382.80	0.00	-0.02
P01B	9/4/96	5.86	116.98	35.09	162.40	45.90	437.00	9.40		44.40	391.60	0.00	-0.02
P01B	12/3/96	6.23	116.00	32.10	161.60	58.60	422.00		-283.00	96.50	384.20	5.00	-0.02
P01B	3/4/97	6.92	121.00	34.00	170.30	54.50	442.00		-204.00	96.90	387.80	1.00	-0.02
P01B	6/4/97	7.39	114.00	32.30	153.40	46.50	418.00	15.00		31.70	386.40		-0.02
P01B	9/4/97	6.90	120.00	35.00	160.60	53.00	418.00	8.30		-4.00	378.20		-0.02
P01B	12/2/97												

Table E-1. Ground Water Quality at Station PO1B in the Everglades Nutrient Removal Project (Continued).

STATION CODE	DATE	TKNH4-MG/L	TOTAL N-MG/L	TDOPC-MG/L	NO3NH4-MG/L	ALKALINITY-MG/L	TDOPC-MG/L	TOTAL PB-MG/L	TOTAL AS-MG/L	TOTAL PB-MG/L	TOTAL BA-MG/L	TDSS-MG/L	TDSS-PCF
P01B	12/7/94	1.84	3.83	33.60	1.99	7.40	32.30	-0.20	-1.50	0.91	22.40	786.00	120.00
P01B	3/7/95	2.14	4.18	35.90	2.04	7.30	35.90	-0.20	-1.50	-0.50	16.98	798.00	205.00
P01B	6/7/95	2.28	3.85	35.80	1.57	7.20	29.50	-0.20	-1.50	-0.50	9.90	800.00	46.00
P01B	9/6/95	1.34	3.39	47.10	2.05	7.60	40.90	-0.20	1.65	-0.50	8.00	829.00	46.30
P01B	12/5/95		4.11				33.60	-0.20	-1.50	0.82	6.75		212.40
P01B	3/6/96	2.39	4.23	34.50	1.84	7.40	36.30	-0.20	1.61	-0.80	6.43	830.00	125.90
P01B	6/3/96	2.62	4.64	37.00	2.02	7.70	33.80	-0.20	-1.50	-0.80	5.50	819.00	3.20
P01B	9/4/96	1.77	3.94		2.18	7.80		-0.20	-1.50	-0.80	6.14	833.00	32.40
P01B	12/3/96	2.33	5.15	37.40	2.82	7.70	34.80	-0.20	-1.50	-0.80	5.24	776.00	75.90
P01B	3/4/97	1.90	3.93	34.70	2.07	7.80	41.50	-0.20	-1.50	-0.80	5.99	820.00	24.30
P01B	6/4/97	2.95		36.30		7.70	36.40	-0.20	-1.50	0.88	5.89	834.00	90.90
P01B	9/4/97	2.82	4.75	37.00	1.93	7.60	34.90	-0.20	-1.50	-0.80	5.30	8.00	21.50
P01B	12/2/97												-3.00

Table E-2. Ground Water Quality at Station P02A in the Everglades Nutrient Removal Project.

STATION CODE	DATE Mo/day/yr	TEMP CENT	D.O. MGL	SP COND UMHOS/CM	PH UNITS	TURB NTU	NOX MG/NL	NO2 MG/NL	NH4 MG/NL	TKN MG/NL	CP04 MG/PIL	TP04 MG/PIL	SI02 MGL	NA MGL
P02A	12/6/94	26.60		171	7.12	33.00	0.03	0.00	1.00	2.20	0.017	0.018	29.90	143.00
P02A	3/6/95	23.10		1414	7.16	45.00	0.00	0.00	0.95	3.61	0.010	0.053	29.90	151.00
P02A	6/6/95	24.00		983	7.40	875.00	0.00	0.00	0.85	3.24		0.194	32.60	102.20
P02A	9/5/95	27.40		1213	7.08	46.50	0.04	0.00	0.98	3.15	0.011	0.035	20.30	75.93
P02A	12/6/95	26.10		911	7.23		0.04	0.00		3.29	0.007	0.013	23.50	60.36
P02A	3/5/96	23.90		696	7.37	12.50	0.00	0.00	0.75	1.24	0.006	0.024	151.30	80.51
P02A	6/4/96	22.90		1000	7.14	21.80	0.07	0.00	0.97	2.04	-0.004	0.021	32.00	90.32
P02A	9/5/96	27.20	0.40	949	7.15	11.00	-0.02	0.00	1.62	2.64	-0.004	0.015	32.00	107.00
P02A	12/4/96	27.50	0.40	1084	7.28	36.60	0.00	0.00	2.28	4.52	0.006	0.017	28.90	86.90
P02A	3/5/97	25.40	0.30	966	7.34	59.00	0.31	0.00	0.92	2.48	0.004	0.000	32.70	108.22
P02A	6/4/97	24.70	1.00	1141	7.22	67.90	0.00	0.00	1.48	3.91	0.005	0.050	20.10	140.00
P02A	9/4/97	26.60	0.70	1327	6.95	61.0	0.01		1.50	4.55	0.007	0.014		
P02A	12/2/97	27.00	0.90	1134	7.18									

STATION CODE	DATE Mo/day/yr	K MGL	CA MGL	MG MH/L	CL MGL	SO4 MGL	HARDNESS MG/LCAO	SULFIDE MGL	OXFRED P MILLI VOL	TOTAL AL MICROGIL	ALKALINITY MGL	%SAT. DO PERCENT	NO3 MG/NL
P02A	12/6/94	11.60	87.50	26.60	170.60	50.90	328.00		-50.00	3550.00	327.70		0.02
P02A	3/6/95	10.45	102.00	33.00	199.90	61.90	391.00		-52.00	1177.00	385.70		0.00
P02A	6/6/95	8.65	63.90	22.50			252.00		0.00	3835.00	529.40		
P02A	9/5/95	17.53	94.07	30.00	155.10	48.60	358.00		-13.00	2300.50	292.10		0.04
P02A	12/6/95	10.36	55.76	20.57	112.50	43.20	249.00		-13.00	331.40			0.04
P02A	3/5/96	7.72	61.44	18.49	86.50	29.00	230.00		-17.00	785.00	193.30		-0.02
P02A	6/4/96	6.59	76.25	23.40	127.20	32.90	287.00		3.00	562.50	220.30		0.07
P02A	9/5/96	7.79	73.28	22.89	196.90	26.90	277.00	3.40	-257.00	496.90	272.80	5.00	-0.02
P02A	12/4/96	10.00	98.10	25.30	147.20	38.60	324.00		-224.00	280.00	303.70	5.00	-0.02
P02A	3/5/97	10.30	50.10	23.90	129.80	32.20	298.00		-198.00	1450.00	276.80	3.00	0.31
P02A	6/4/97	9.94	92.78	27.17	150.70	28.50	344.00			1710.00	326.90	12.00	-0.02
P02A	9/4/97	11.00	97.00	29.00	177.90	31.30		13.00		242.00	353.60	9.00	-0.02
P02A	12/2/97												

Table E-2. Ground Water Quality at Station PO2A in the Everglades Nutrient Removal Project (Continued).

STATION CODE	DATE MO/YR	TOTAL N MG/L	TDORGC MG/L	NO ₃ -NH ₄ MG/L	ALKALINITY MG/L	TOTOC MG/L	TOTAL HG MICROG/L	TOTAL AS MICROG/L	TOTAL PB MICROG/L	TOTAL BA MICROG/L	IDS.SOL MG/L	PO ₄ -P MICROG/L	TDSEE MICROG/L
PO2A	12/6/94	1.20	37.60	1.02	6.60	38.40	-0.20	4.45	1.97	121.90	775.00	4960.00	88.00
PO2A	3/6/95	2.63	38.30	0.99	7.70	38.80	0.30	2.69	0.81	141.39	907.00	2680.00	28.00
PO2A	6/6/95	2.99	30.20	0.85	10.60	44.50	-0.20	5.98	2.55	109.00	654.00	9900.00	23.00
PO2A	9/5/95	2.17	53.30	1.02	5.80	53.50	-0.20	2.49	0.78	73.16	730.00	159.20	15.12
PO2A	12/6/95	3.33				29.40		-1.50	-0.80	84.20		419.10	10.27
PO2A	3/5/96	1.24	23.30		3.90	26.30	-0.20	2.50	-0.80	36.31	427.00	567.60	13.20
PO2A	6/4/96	1.07	28.10	1.04	4.40	26.20	-0.20	1.62	-0.80	39.37	526.00	427.20	12.90
PO2A	9/5/96	1.02	2.66	1.64	5.50		-0.20	-1.50	-0.80	50.95	636.00	385.20	8.20
PO2A	12/4/96	2.54	34.00	2.28	6.10	34.40	-0.20	2.88	-0.80	51.70	605.00	870.00	8.44
PO2A	3/5/97	1.56	27.80	1.23	5.50	24.20	-0.20	2.95	-0.80	48.50	593.00	917.00	10.10
PO2A	6/4/97	2.43	32.30	1.49	6.50	30.30	-0.20	3.45	-0.80	54.20	622.00	1460.00	10.00
PO2A	9/4/97	2.55	37.80	1.81	7.10	37.50	-0.20	4.16	0.80		808.00	156.00	5.74
PO2A	12/2/97												

Table E-3. Ground Water Quality at Station PO4A in the Everglades Nutrient Removal Project.

STATION CODE	DATE	TEMP CENT.	D.O. MG/L	SP COND UMHOS/CM	PH UNITS	TURB NTU	NOX MG/NL	NO2 MG/NL	NH4 MG/NL	TKN MG/NL	OP04 MG/P/L	TP04 MG/P/L	SI02 MG/L	NA MG/L
P03A	12/6/94	25.40		1053	7.23	55.00	0.01	0.00	1.37	3.14	0.005	0.072	21.20	117.00
P03A	3/6/95	18.90		1230	7.12	102.00	0.00	0.00	1.34	3.90	0.005	0.032	23.60	142.00
P03A	6/6/95	26.00		911	7.32	390.00	0.00	0.00	1.04	2.94	0.004	0.045	26.00	85.90
P03A	9/5/95	28.50		1230	7.00		0.01	0.00	1.71	4.18	0.012	0.060	33.00	140.35
P03A	12/6/95	26.40		890	7.12		0.00	0.00		3.48	0.013	0.034	26.60	78.40
P03A	3/5/96	20.40		700	7.30	9.20	0.00	0.00	1.46	1.85	-0.004	0.014	22.60	55.62
P03A	6/4/96	23.30		949	7.09	9.80	-0.02	0.00	1.91	2.36	0.004	0.020	152.40	80.09
P03A	9/5/96	28.30	0.20	1033	6.95	26.80	-0.02	0.00	2.62	4.55	0.005	0.016	40.50	93.77
P03A	12/4/96	27.60	0.40	1082	7.21	24.90	0.00	0.00	3.15	6.15	0.012	0.019	18.20	104.00
P03A	3/5/97	22.70	0.50	954	7.25	76.20	0.01	0.00	2.75	3.53	0.005	0.027	28.90	81.30
P03A	6/4/97	25.00	0.40	1170	7.09	41.10	0.00	0.00	2.81	4.91	0.008	0.028	33.90	101.00
P03A	9/4/97	27.90	1.40	1350	6.92									140.00
P03A	12/2/97	26.50	1.10	1109	7.08									

STATION CODE	DATE	K MG/L	CA MG/L	MG MHL	CL MG/L	S04 MG/L	HARDNESS MG/LCAO	SULFIDE MG/L	OXRED.P MLI VOL.	TOTAL AL MICROG/L	ALKALINITY MG/L	%SAT. DO PERCENT	NO3 MG/NL	
P03A	12/6/94	10.35	74.50	24.95	148.20	38.20	288.00		-68.00	974.60	273.20		0.00	
P03A	3/6/95	8.80	83.50	27.50	173.90	50.80	322.00		-40.00	1935.00	365.20		0.00	
P03A	6/6/95	8.66	59.10	20.60	103.90	8.20	232.00		-62.00	2078.00	256.40		0.00	
P03A	9/5/95	17.77	96.04	31.34	157.40	31.10	369.00		-59.00	1412.40	328.10		0.00	
P03A	12/6/95	9.31	71.77	23.22	112.00	21.70	275.00		-44.00	275.70			0.00	
P03A	3/5/96	6.37	64.28	19.51	83.30	15.20	241.00		-35.00	28.20	202.50		-0.02	
P03A	6/4/96	8.01	71.82	22.59	27.50	11.80	272.00		-298.00	124.10	240.40		-0.02	
P03A	9/5/96	8.47	82.53	25.47	23.90	1.00	311.00	5.20	-234.00	75.20	347.60	2.00	-0.02	
P03A	12/4/96	9.28	84.40	26.90	36.50	13.60	321.00		-201.00	111.00	141.90	5.00	-0.02	
P03A	3/5/97	9.06	79.90	23.90	22.70	17.20	298.00		-201.00	463.00	302.50	5.00	-0.02	
P03A	6/4/97	10.80	91.20	26.90	151.80	13.10	338.00			289.00	295.20	5.00	-0.02	
P03A	9/4/97	9.90	93.00	27.00				26.00						
P03A	12/2/97							12.00						

Table E-3. Ground Water Quality at Station P03A in the Everglades Nutrient Removal Project (Continued).

STATION CODE	DATE	TKNH ₄ -N (MG/L)	TOTAL N (MG/L)	TDORC (MG/L)	NO ₃ -N (MG/L)	NO ₂ -N (MG/L)	ALUMINUM (MG/L)	TOPOC (MG/L)	TOTAL P ₅ (MG/L)	TOTAL AS (MG/L)	TOTAL PB (MG/L)	TOTAL BA (MG/L)	SDS (MG/L)	TOI (MG/L)	TDSTP (MG/L)
P03A	12/6/94	1.78	3.15	34.50	1.37	5.50	42.70	-0.20	3.64	0.76	167.50	665.00	758.00	-20.00	
P03A	3/6/95	2.56	3.91	42.60	1.35	7.30	45.60	-0.20	3.34	-0.50	198.20	779.00	220.00	-20.00	
P03A	6/6/95	1.91	2.95	29.40	1.04	5.10	33.60	0.20	3.27	-0.50	109.40	619.00	943.00	-20.00	
P03A	9/5/95	2.47	4.19	68.40	1.72	6.60	62.60	-0.20	4.65	0.55	146.87	795.00	1966.90	5.64	
P03A	12/6/95		3.49				31.60	-0.20	-1.50	-0.80	86.74	420.00	300.30	3.34	
P03A	3/5/96	-0.50	1.86	25.40	1.46	4.10	28.60	-0.20	-1.50	-0.80	59.45	545.00	154.20	-3.00	
P03A	6/4/96	-0.50	2.37	28.50	1.92	4.80	26.50	-0.20	-1.50	-0.80	72.25	545.00	154.20	-3.00	
P03A	9/5/96	1.94	4.57		2.63	6.90	35.10	-0.20	2.18	-0.80	97.07	608.00	137.80	3.20	
P03A	12/4/96	3.03	6.18	34.20	3.16	2.90	24.60	-0.20	-1.50	0.80	88.50	609.00	131.00	4.43	
P03A	3/5/97	0.78	3.54	26.90	2.76	6.10	24.60	-0.20	1.99	-0.80	77.90	584.00	520.00	7.52	
P03A	6/4/97	2.11	4.92		2.81	5.90	28.70	-0.20	3.68	-0.80	89.20	632.00	344.00	7.89	
P03A	9/4/97														
P03A	12/2/97														

Table E-4. Ground Water Quality at Station P04A in the Everglades Nutrient Removal Project.

STATION CODE	DATE	TEMP CENT.	D.O. MGL	SP COND UMHS/CM	PH UNITS	TURB NTU	NOX MG/NL	NO2 MG/NL	NH4 MG/NL	TKN MG/NL	OP04 MG P/L	TP04 MG P/L	SI02 MGL	NA MGL
P04A	12/6/94	26.50	1.002	1364	6.90	131.00	0.02	0.00	0.85	2.61	-0.004	0.063	14.50	114.00
P04A	3/6/96	21.80	1.364	949	7.24	161.00	0.03	0.00	0.74	3.62	-0.004	0.035	17.90	150.50
P04A	6/6/96	22.90	1244	195.00	6.94		0.00	0.00	0.64	4.67	-0.004	0.090	20.40	98.50
P04A	9/5/96	27.30	912		6.94		0.03	0.00	1.00	3.37	-0.004	0.070	25.90	135.82
P04A	12/6/96	26.70	700		7.08		0.01	0.00	0.16	3.16	0.013	0.026	28.40	81.37
P04A	3/5/96	21.50	878		7.23	18.80	0.02	0.00	0.67	1.70	-0.004	0.014	14.50	58.51
P04A	6/4/96	21.90	878		7.08	2.90	-0.02	0.00	0.81	1.77	-0.004	0.012	16.90	70.12
P04A	9/5/96	27.50	916		7.02	14.60	0.02	0.00	2.15	2.66	-0.004	0.013	21.90	79.60
P04A	12/4/96	27.50	1028		7.14	17.20	0.08	0.00	1.06	4.04	0.006	0.013	18.70	101.00
P04A	3/5/97	23.50	940		7.24	25.00	0.09	0.00	0.89	2.35	0.004	0.012	17.50	78.40
P04A	6/4/97	23.00	1195		7.06	10.90	0.00	0.00	1.17	3.12	-0.004	0.017	22.20	99.90
P04A	9/3/97	26.60	1307		6.93	29.50	0.01	0.01	1.15	3.90	-0.004	0.014	19.70	160.00
P04A	12/2/97	27.10	1047		7.09									

STATION CODE	DATE	K MGL	CA MGL	MG M/L	CL MGL	S04 MGL	HARDNESS MG/LCACO	sulfide MGL	OXYPRED P M/L VOL	TOTAL AL MICROG/L	ALKALINITY MGL	%SAT DO PERCENT	NO3 MG/NL
P04A	12/6/94	10.60	70.50	21.40	133.70	27.70	264.00			5272.00	285.90		0.02
P04A	3/6/96	9.25	88.50	30.00	204.80	69.50	369.00		-15.00	930.90	446.60		0.03
P04A	6/6/96	8.14	88.40	22.00	118.60	22.50	261.00		-42.00	3151.00	274.40		0.00
P04A	9/5/96	17.09	97.20	29.17	169.70	91.10	363.00		-50.00	3160.00	345.80		0.03
P04A	12/6/96	10.09	75.40	22.46	118.90	24.20	281.00		-51.00	838.90			0.01
P04A	3/5/96	6.72	83.42	19.63	89.10	20.60	252.00		-51.00	104.90	218.40		0.02
P04A	6/4/96	6.82	71.94	21.16	117.30	10.20	267.00		-51.00	18.50	245.30		-0.02
P04A	9/5/96	8.02	74.99	20.57	121.10	12.00	272.00	6.80	-394.00	78.10	271.50	3.00	-0.02
P04A	12/4/96	8.63	83.00	23.90	126.30	28.80	306.00		-3.00	504.00	293.40	6.00	0.07
P04A	3/5/97	8.39	82.50	23.20	119.90	21.30	301.00		-197.00	358.00	319.70	4.00	0.09
P04A	6/4/97	9.88	91.30	26.70	157.60	21.90	338.00			351.00	328.90	9.00	-0.02
P04A	9/3/97	11.00	110.00	30.00	178.90	29.90		21.00		138.00	362.90	10.00	-0.02
P04A	12/2/97							6.60					

Table E-4. Ground Water Quality at Station P04A in the Everglades Nutrient Removal Project (Continued).

STATION CODE	DATE	TKNHK MG/L	TOTAL N MG/L	TORGC MG/L	NO ₃ -N MG/L	ALUMINUM MG/L	TORGC MG/L	TOTAL HG MICROG/L	TOTAL AS MICROG/L	TOTAL PB MICROG/L	TOTAL BA MICROG/L	DS SOL MGL	TOTFEI MICROG/L	TDSFEI MICROG/L
P04A	12/6/94	1.75	2.63	36.30	0.88	5.70	37.00	-0.20	4.48	2.72	87.90	697.00	3995.00	23.00
P04A	3/6/95	2.78	3.55	43.20	0.77	8.90	50.20	-0.20	1.90	-0.50	86.93	919.00	225.00	30.00
P04A	6/6/95	2.03	2.67	29.60	0.64	5.50	35.50	-0.20	2.86	-0.50	41.93	641.00	790.00	46.00
P04A	9/5/95	2.37	3.40	63.20	1.03	6.90	64.80	0.30	4.60	1.23	55.19	779.00	969.90	8.78
P04A	12/6/95		3.18				29.20		-1.50	-0.80	31.98		602.60	8.52
P04A	3/5/96	1.03	1.73	24.10	0.70	4.40	28.30	-0.20	-1.50	1.04	19.51	430.00	93.33	7.00
P04A	6/4/96	0.96	1.79	23.60	0.83	4.90	22.90	-0.20	-1.50	-0.80	22.83	535.00	26.40	7.00
P04A	9/5/96	0.50	2.67		2.17	5.40		-0.20	-1.50	-0.80	26.75	544.00	92.00	5.60
P04A	12/4/96	2.98	4.11	31.60	1.14	5.90	34.80	-0.20	2.59	-0.80	32.00	589.00	436.00	8.48
P04A	3/5/97	1.46	2.44	25.80	0.96	6.40	24.50	-0.20	1.91	-0.80	29.60	584.00	257.00	6.99
P04A	6/4/97	1.85	3.13	33.80	1.17	6.60	31.20	-0.20	2.77	-0.80	38.70	707.00	277.00	7.03
P04A	9/3/97	2.75	3.90	40.20	1.15	7.30	4.08	0.25	2.40	-0.80	779.00		180.00	4.72
P04A	12/2/97													

Table E-5. Ground Water Quality at Station P05A in the Everglades Nutrient Removal Project.

STATION CODE	DATE	TEMP CENT.	D.O. MGL	SP COND UMHOS/CM	PH UNITS	TURB NTU	NOX MG/NL	NO2 MG/NL	NH4 MG/NL	TKN MG/NL	OP04 MG P/L	TP04 MG P/L	SI02 MGL	NA MGL
P05A	12/6/94	24.70	1437	1427	6.82	28.00	0.00	0.00	1.61	3.44	0.004	0.525	17.40	176.50
P05A	3/6/95	23.90	1427	1363	6.72	44.00	0.00	0.00	1.47	4.09	0.005	0.02	16.70	156.50
P05A	6/6/95	22.50	1363	1299	6.99	65.00	0.00	0.00	1.17	3.69	-0.004	0.025	16.00	151.00
P05A	9/5/95	24.00	1299	1214	6.80	15.50	0.00	0.00	1.34	3.45	0.011	0.032	18.20	135.89
P05A	12/6/95	24.50	1214	1031	6.75	43.20	0.00	0.00	1.13	3.7	0.015	0.029	19.90	115.53
P05A	3/5/96	24.40	1031	940	6.85	50.20	0.00	0.00	0.99	1.60	-0.004	0.024	17.10	96.12
P05A	6/4/96	23.50	940	1096	6.69	50.20	-0.02	0.00	0.99	2.24	-0.004	0.016	15.10	78.90
P05A	9/5/96	24.30	1096	1174	6.80	23.50	0.02	0.00	1.25	2.8	0.004	0.023	18.20	85.07
P05A	12/4/96	25.20	1174	120	6.88	49.00	0.00	0.00	1.26	3.92	0.006	0.013	19.20	100.00
P05A	3/5/97	24.80	120	109	7.01	71.60	0.00	0.00	1.18	2.83	0.005	0.031	18.90	96.50
P05A	6/4/97	23.30	109	1212	6.97	13.50	0.00	0.00	1.24	3.29	0.004	0.015	17.40	110.00
P05A	9/3/97	24.30	1212	1303	6.85									120.00
P05A	12/3/97	25.10	1303		6.87									

STATION CODE	DATE	K MG/L	CA MG/L	MG MHL	CL MG/L	S04 MG/L	HARDNESS MG/L/CAO	SULFIDE MG/L	OXFRED P ML/VOL	TOTAL AL MICROG/L	ALKALINITY MG/L	%SAT. DO PERCENT	NO3 MG/NL
P05A	12/6/94	15.20	113.00	26.55	202.40	11.60	391.00		-51.00	31203.00	511.90		0.00
P05A	3/6/95	14.55	115.00	27.00	196.50	19.70	398.00		-54.00	183.30	414.80		0.00
P05A	6/6/95	13.73	110.00	28.00	169.50	29.40	390.00		-6.00	54.20	363.90		0.00
P05A	9/5/95	20.94	110.56	26.29	158.00	19.30	364.00		-36.00	681.00	390.80		0.01
P05A	12/6/95	15.40	106.4	25.45	145.80	13.40	370.00		-58.00	1172.30			0.00
P05A	3/5/96	13.51	100.06	23.21	120.90	12.90	345.00		-40.00	459.50	352.00		-0.02
P05A	6/4/96	10.38	83.45	19.50	104.00	11.60	289.00		-11.00	225.90	314.40		-0.02
P05A	9/5/96	10.61	110.60	25.02	131.40	11.80	379.00	6.10	-280.00	152.10	340.90	2.00	-0.02
P05A	12/4/96	11.20	114.00	26.40	147.90	7.30	393.00	7.70	-3.00	457.00	382.90	6.00	-0.02
P05A	3/5/97	12.30	103.00	24.30	135.00	8.30	357.00		-204.00	538.00	415.70	2.00	-0.02
P05A	6/4/97	10.10	99.80	27.80	127.10	8.40	364.00			136.00	334.10	3.00	-0.02
P05A	9/3/97	11.00	110.00	24.00				19.00					
P05A	12/3/97							8.80					

Table E-5. Ground Water Quality at Station P05A in the Everglades Nutrient Removal Project (Continued).

STATION CODE	DATE	IRON	TOTAL N	TOTAL P	NO ₃ -N	ALUMINUM	TOTAL Fe	TOTAL AS	TOTAL Pb	TOTAL Ba	EDS-SCl	TOTAL Fe	IDS-Fe
	Mo/day	MG/L	MG/L	MG/L	MG/L	MG/L	MG/L	MG/L	MG/L	MG/L	MG/L	MG/L	MG/L
P05A	12/6/94	1.83	3.44	47.40	1.61	10.20	54.10	-0.20	12.84	301.40	903.00	13080.00	61.00
P05A	3/6/95	2.62	4.10	44.90	1.47	8.30	50.60	-0.20	-0.50	151.95	898.00	82.00	21.00
P05A	6/6/95	2.52	3.69	42.10	1.18	7.70	46.90	0.20	-0.50	85.40	871.00	294.00	-20.00
P05A	9/5/95	2.11	3.46	76.80	1.35	7.60	56.90	-0.20	-0.50	76.91	777.00	56.30	8.20
P05A	12/6/95		3.72				39.30	-0.20	-0.80	71.56		920.60	3.86
P05A	3/5/96	-0.50	1.61	38.80	1.13	7.00	41.90	-0.20	-0.80	62.02	637.00	453.52	-3.00
P05A	6/4/96	1.25	2.26	30.40	1.01	6.30	29.40	-0.20	-0.80	53.24	581.00	172.90	29.20
P05A	9/5/96	1.56	2.83		1.27	6.80		-0.20	-0.80	63.53	578.00	141.70	8.00
P05A	12/4/96	2.67	3.93	36.80	1.26	7.70	36.40	-0.20	-0.80	63.70	687.00	284.00	-3.00
P05A	3/5/97	1.65	2.83	34.30	1.18	8.30	31.50	-0.20	1.02	61.90	692.00	700.00	7.59
P05A	6/4/97	2.05	3.29	34.90	1.24	6.70	32.50	-0.20	-0.80	59.80	656.00	98.50	-3.00
P05A	9/3/97												
P05A	12/3/97												

Table E-6. Ground Water Quality at Station P06A in the Everglades Nutrient Removal Project.

STATION CODE	DATE	TEMP CENT.	D.O. MGL	SP COND UMHOS/CM	PH UNITS	TURB NTU	NOX MG/NL	NO2 MG/NL	NH4 MG/NL	TKN MG/NL	CP04 MG P/L	TP04 MG P/L	SI02 MG/L	NA MG/L
P06A	12/6/94	25.40	1136	6.84	170.00	0.00	0.00	1.23	4.64	0.006	0.148	16.90	134.00	
P06A	3/6/95	22.00	1434	6.69	675.00	0.01	0.00	2.13	6.47	0.007	0.256	18.10	150.00	
P06A	6/6/95	25.50	1104	6.98	2100.00	0.00	0.00	2.05	5.99	0.004	0.287	18.10	119.00	
P06A	9/5/95	27.60	1181	6.74		0.40	0.00	1.85	1.43	0.017	0.058	20.50	116.74	
P06A	12/6/95	25.70	1006	6.72		0.00	0.00	2.09	3.60	0.014	0.028	22.00	97.92	
P06A	3/7/96	22.30	886	6.97	78.70	0.00	0.00	1.97	2.11	0.010	0.037	19.80	85.44	
P06A	6/4/96	25.00	854	6.89	34.70	-0.02	0.00	2.50	1.31	0.016	0.030	19.40	74.04	
P06A	9/5/96	27.20	984	6.85	106.00	-0.02	0.00	2.50	4.16	0.004	0.044	23.40	90.55	
P06A	12/4/96	25.30	1047	6.93	53.60	0.00	0.00	2.78	5.82	0.013	0.035	24.30	95.20	
P06A	3/5/97	25.30	1009	7.07	68.80	0.00	0.00	2.33	5.35	0.011	0.130	24.40	82.20	
P06A	6/4/97	24.40	1033	7.02		0.00	0.00	2.40	4.47	0.007	0.005	24.60	89.20	
P06A	9/3/97	29.50	1152	6.94	59.80	0.00	0.01	2.85	5.49	0.006	0.039	27.20	120.00	
P06A	12/3/97	24.90	1176	6.90										

STATION CODE	DATE	K MGL	CA MGL	MG MHL	CL MGL	S04 MGL	HARDNESS MGL/CACO	SULFIDE MGL	OXYRED P MILLI VOL	TOTAL AL MICROG/L	ALKALINITY MGL	%SAT. DO PERCENT	NO3 MG/NL
P06A	12/6/94	13.60	96.50	16.15	153.40	6.40	307.00		-14.00	9044.00	387.10		0.00
P06A	3/6/95	12.70	125.50	19.50	200.60	44.30	394.00		-15.00	4943.00	403.80		0.00
P06A	6/6/95	12.00	106.50	15.50	152.10	9.70	330.00		46.00	5147.00	355.90		0.00
P06A	9/5/95	19.22	99.97	16.55	105.40	11.90	318.00		47.00	2932.90	297.50		0.39
P06A	12/6/95	12.83	93.66	14.97	125.50	5.30	295.00		2.00	81.80			-0.02
P06A	3/7/96	10.37	87.72	13.92	103.70	6.40	276.00		0.00	1196.80	306.30		-0.02
P06A	6/4/96	9.27	77.06	12.93	106.20	3.40	246.00		58.00	905.10	287.90		-0.02
P06A	9/5/96	10.07	102.01	17.86	137.00	-1.00	328.00	-1.00	-179.00	1174.60	149.50	6.00	-0.02
P06A	12/4/96	10.10	107.00	17.70	142.40	1.90	340.00	1.40	-154.00	1530.00	369.40	11.00	-0.02
P06A	3/5/97	10.70	96.30	16.10	125.20	1.50	307.00		-83.00	885.00		7.00	-0.02
P06A	6/4/97	11.40	100.00	17.10	129.20	-1.00	320.00				315.90	7.00	-0.02
P06A	9/3/97	12.00	100.00	19.00	150.50	-1.00		4.70		4180.00	419.40	6.00	-0.02
P06A	12/3/97							1.40					

Table E-6. Ground Water Quality at Station P06A in the Everglades Nutrient Removal Project (Continued).

STATION CODE	DATE M/d/yr	TOTAL N MG/L	TOTAL P MG/L	TDORGC MG/L	NO ₃ -N MG/L	ALUMINUM MG/L	TOTORC MG/L	TOTAL HG MG/L	TOTAL AS MG/L	TOTAL PB MG/L	TOTAL BA MG/L	IDS SOL MG/L	TOFEEI MICROG/L	TDSEEI MICROG/L
P06A	12/6/94	3.41	4.65	47.40	1.24	7.70	52.30	-0.20	2.97	2.58	217.70	842.00	4040.00	336.00
P06A	3/6/95	4.34	6.48	61.80	2.14	8.10	67.60	0.20	5.74	3.10	200.90	936.00	754.00	273.00
P06A	6/6/95	3.94	5.99	44.00	2.05	7.30	56.30	0.20	4.24	2.58	234.20	962.00	2955.00	941.00
P06A	9/5/95	-0.50	1.83	66.20	2.25	5.90	18.80	-0.20	2.85	1.16	106.04	184.00	960.50	154.03
P06A	12/6/95	3.60	3.60				34.80	-0.80	-1.50	-0.80	58.25		71.20	119.98
P06A	3/7/96	-0.50	2.12	37.30	2.10	6.10	36.40	-0.20	1.87	0.99	85.41	556.00	1102.10	89.80
P06A	6/4/96	-0.50	1.32	28.40	1.99	5.80	31.40	-0.20	-1.50	-0.80	76.29	529.00	948.00	82.60
P06A	9/5/96	1.66	4.17		2.51	3.00		-0.20	-1.50	-0.60	97.42	636.00	1027.20	70.90
P06A	12/4/96	3.04	5.83	45.10	2.79	7.40	35.60	-0.20	1.89	-0.80	91.40	546.00	1440.00	71.80
P06A	3/5/97	3.02	5.36	33.70	2.33		29.80	-0.20	1.63	3.14	90.80	630.00	738.00	74.90
P06A	6/4/97	2.01	4.41	35.40	2.41	6.30	33.20	-0.20	1.54	-0.80		632.00		
P06A	9/3/97	2.64	5.49	37.50	2.85	8.40	37.50	-0.20	2.30	2.33		654.00	2700.00	48.80
P06A	12/3/97													

Table E-7. Ground Water Quality at Station P07A in the Everglades Nutrient Removal Project.

STATION CODE	DATE	TEMP	D.O.	SPCOND	PH	TURB	NOX	NO2	NH4	TKN	OP04	TP04	SI02	NA
	Mo/dayr	CENT	MG/L	UMHOSOM	UNITS	NTU	MG/L	MG/L	MG/L	MG/L	MG P/L	MG P/L	MG/L	MG/L
P07A	12/6/94	26.00		924	6.90	32.00	0.04	0.00	0.79	2.03	-0.004	0.020	13.70	104.00
P07A	3/6/95	19.70		1422	6.91	49.00	0.0	0.00	0.86	3.54	0.004	0.018	13.70	154.00
P07A	6/6/95	25.70		997	7.18	385.00	0.00	0.00	0.66	2.94	-0.004	0.014	17.50	106.50
P07A	9/5/95	28.40		1066	6.94		0.0	0.00	0.88	2.81	0.005	0.112	22.70	123.32
P07A	12/6/95	26.20		945	7.02		0.00	0.00		1.04	0.004	0.023	20.40	86.97
P07A	3/7/96	20.20		826	7.14	5.70	0.0	0.00		2.21	0.014	0.013	14.70	72.32
P07A	6/4/96	26.30		839	7.05	38.90	-0.02	0.00	0.69	1.78	-0.004	0.014	17.40	75.38
P07A	9/5/96	29.00	0.30	847	6.96		-0.02	0.00	0.86	2.22	-0.004		21.60	76.56
P07A	12/5/96	26.20	0.40	1015	7.11	122.00	0.03	0.00	0.82	3.46	0.012	0.026	19.80	96.20
P07A	3/6/97	22.00	0.40	980	7.20	84.00	0.63	0.04	0.15	1.01	-0.004	0.012	4.80	45.40
P07A	6/5/97	25.20	0.40	1081	7.15	43.20	0.00	0.00	0.77	2.69	0.005	0.013	16.40	99.20
P07A	9/4/97	28.60	0.70	1021	7.04	106.00	0.06	0.0	0.8	3.13	0.004	0.028	22.40	120.00
P07A	12/3/97	26.00	0.80	1192	7.07									

STATION CODE	DATE	K	CA	MG	CL	S04	HARDNESS	SULFIDE	OXYPED P	TOTAL AL	ALKALINITY	%SAT. DO	NO3	
	Mo/dayr	MG/L	MG/L	MH/L	MG/L	MG/L	MG/L/CAOO	MG/L	MLL/VOL	MICROG/L	MG/L	PERCENT	MG/L	
P07A	12/6/94	9.05	71.00	17.95	122.60	21.50	251.00			538.90	266.40		0.04	
P07A	3/6/95	9.20	106.00	29.00	212.90	58.60	394.00		-30.00	117.50	438.40		0.01	
P07A	6/6/95	9.02	67.60	19.80	140.60	8.50	250.00		4.00		279.80		0.00	
P07A	9/5/95	14.48	83.17	22.96	146.00	11.40	302.00		8.00	-4017.30	377.10		0.00	
P07A	12/6/95	10.12	76.14	20.97	125.50	19.60	276.00		6.00	81.10			-0.02	
P07A	3/7/96	7.45	73.14	20.9	103.30	14.50	269.00		-26.00	53.40	243.00		-0.02	
P07A	6/4/96	7.89	67.56	18.87	102.60	8.30	246.00	3.40	-24.00	13.70	259.30		-0.02	
P07A	9/5/96	7.39		20.0	113.30	4.90	263.00		-267.00			4.00	-0.02	
P07A	12/5/96	8.06	86.30	22.60	134.30	24.40	309.00	3.20	-237.00	1230.00	328.90	5.00	0.03	
P07A	3/6/97	5.08	62.70	13.90	98.70	55.80	214.00		175.00	941.00	103.20	4.00	0.60	
P07A	6/5/97	12.90	144.00	66.10	148.90	8.90	632.00			419.00	270.50	5.00	-0.02	
P07A	9/4/97	9.30	75.00	21.00	154.30	11.10		16.00		1020.00	292.70	9.00	0.05	
P07A	12/3/97							3.00						

Table E-7. Ground Water Quality at Station P07A in the Everglades Nutrient Removal Project (Continued).

STATION CODE	DATE	TURBIDITY	TOTAL N	TOTAL P	TDORC	NO ₃ -N	NO ₂ -N	AMMONIA	TOTAL AS	TOTAL PS	TOTAL BA	IDS SOL	TOIFEI	TDSEI
	MM/DD/YY	MG/L	MG/L	MG/L	MG/L	MG/L	MG/L	MG/L	MG/L	MG/L	MG/L	MG/L	MG/L	MG/L
P07A	12/6/94	1.25	2.07	52.00	0.83	5.30	33.00	-0.20	-1.50	-0.50	89.70	587.00	370.00	33.00
P07A	3/6/95	2.88	3.55	45.50	0.87	8.80	52.90	-0.20	-1.50	-0.50	147.09	849.00	206.00	81.00
P07A	6/6/96	2.28	2.95	37.40	0.67	5.60	41.20	0.20				648.00		43.00
P07A	9/5/95	1.93	2.82	79.00	0.89	7.50	61.40	0.20	6.47	2.74	101.67	689.00	835.20	36.68
P07A	12/6/95		1.04				31.60	-0.20	-1.50	-0.80	58.40	485.00	72.20	6.00
P07A	3/7/96		2.22	25.70		4.90	24.60	-0.20	-1.50	-0.80	50.75	485.00	45.10	6.40
P07A	6/4/96	1.09	1.80	27.90	0.71	5.20	27.90	-0.20	-1.50	1.40	1.65	493.00	8.80	4.40
P07A	9/5/96	1.35	2.23		0.88	5.80		-0.20	-1.50	-0.80		564.00		
P07A	12/5/96	2.61	3.46	34.40	0.85	6.60	32.40	-0.20	2.46	4.60	59.60	550.00	651.00	8.36
P07A	3/6/97	0.86	1.64	27.30	0.78	2.10	6.30	-0.20	-1.50	-0.80	25.30	234.00	519.00	20.40
P07A	6/5/97	1.92	2.69	35.50	0.78	5.40	34.90	-0.20	2.85	-0.80	57.70	582.00	254.00	3.00
P07A	9/4/97	2.32	3.19	36.10	0.87	5.80	36.30	-0.20	1.90	1.25		632.00	628.00	8.31
P07A	12/3/97													

Table E-8. Ground Water Quality at Station P08B in the Everglades Nutrient Removal Project.

STATION CODE	DATE	TEMP	D.O.	SP COND.	PH	TURB.	NOX	NO2	NH4	TKN	CP04	TP04	SI02	NA
	Mo/dayr	CENT.	MGL	UMFOS/CM	UNITS	NTU	MG/NL	MG/NL	MG/NL	MG/NL	MG/PIL	MG/PIL	MGL	MGL
P08B	12/7/94	23.50		1391	6.63	8.60	0.01	0.00	1.73	3.61	0.008	0.025	25.40	135.50
P08B	3/7/95	23.20		1373	6.91	5.20	0.89	0.00	0.86	3.17	-0.004	0.022	24.40	127.00
P08B	6/7/95	23.90		1367	7.01	3.70	0.01	0.00	2.00	3.73	0.007	0.012	26.50	127.50
P08B	9/6/95	23.60		1400	6.88	2.60	0.01	0.00	2.32	3.29	0.008	0.018	25.20	133.75
P08B	12/5/95	23.60	4.00	1351	6.79		0.01	0.00		3.40	-0.004	0.015	25.70	131.65
P08B	3/6/96	23.40		1366	6.90	1.10	0.00	0.00	1.97	4.09	0.004	0.014	23.60	131.92
P08B	6/5/96	24.40		1410	7.05	6.60	-0.02	0.00	2.08	3.61	0.005	0.027	138.10	122.62
P08B	9/6/96	24.00	0.20	1313	6.89	1.70	-0.02	0.00	2.29	3.48	0.007	0.011	24.40	107.58
P08B	12/5/96	23.70	0.30	1420	7.00	2.90	0.00	0.00	2.00	5.14	0.008	0.011	24.50	139.00
P08B	3/6/97	23.50	0.30	1433	7.06	1.60	0.33	0.01	1.46	3.36	-0.004	0.008	25.90	123.00
P08B	6/5/97	23.50	0.40	1452	6.98	1.30	0.00	0.00	2.12	3.33	0.007	0.009	25.20	107.00
P08B	9/4/97	23.60	1.20	1433	6.97	1.20	0.00	0.01	1.99	4.36	0.004	0.012	24.70	150.00
P08B	12/4/97	23.30	0.70	1439	6.93									

STATION CODE	DATE	K	CA	MG	CL	S04	HARDNESS	SULFIDE	OXYD P	TOTAL AL	ALKALINITY	%SAT. DO	NO3
	Mo/dayr	MGL	MGL	MHL	MGL	MGL	MGL/CACO	MGL	MILLI VOL	MICROG/L	MGL	PERCENT	MG/NL
P08B	12/7/94	8.40	94.50	52.90	150.80	31.00	454.00		-46.00	73.30	457.00		0.00
P08B	3/7/95	7.80	92.00	50.00	145.20	30.90	436.00		-67.00	62.30	438.70		0.89
P08B	6/7/95	8.15	91.00	51.50	154.70	30.30	439.00		22.00	21.80	434.80		0.00
P08B	9/6/95	9.71	91.34	49.90	158.00	33.50	433.00		-25.00	63.10	416.10		0.01
P08B	12/5/95	10.65	95.95	51.53	157.00	31.40	462.00		-7.00	35.50	442.60	47.00	0.00
P08B	3/6/96	10.20	96.50	51.51	170.80	35.50	433.00		-26.00	19.40	456.40		-0.02
P08B	6/5/96	8.74	83.80	45.33	31.50	7.60	408.00		16.00	67.40	442.80		-0.02
P08B	9/6/96	6.90	94.88	46.65	154.70	44.20	429.00	3.70	-294.00	34.50	442.80	2.00	-0.02
P08B	12/5/96	8.00	107.00	54.80	166.50	46.80	463.00	3.20	-258.00	22.70	454.30	3.00	-0.02
P08B	3/6/97	9.81	101.00	50.90	145.00	46.60	462.00		-153.00	70.10	449.00	3.00	0.32
P08B	6/5/97	9.98	80.80	22.70	150.80	55.40	285.00			39.80	455.20	4.00	-0.02
P08B	9/4/97	8.70	110.00	53.00	152.90	61.90		5.90		12.80	456.30	14.00	-0.02
P08B	12/4/97							3.00					

Table E-8. Ground Water Quality at Station P08B in the Everglades Nutrient Removal Project (Continued).

STATION CODE	DATE	TKNH4 MG/L	TOTALN MG/L	TDOPC MGL	NO3-N4 MG/L	ALCALINM MGL	TDORC-C MGL	TOTAL-HG MCG/L	TOTAL-AS MCG/L	TOTAL-PB MCG/L	TOTAL-BA MCG/L	TDSSOL MGL	TDIFEI MCG/L	IDSFEI MCG/L
P08B	12/7/94	1.89	3.62	38.20	1.74	9.10	31.60	-0.20	-1.50	-0.50	19.32	828.00	121.00	54.00
P08B	3/7/95	2.31	4.06	31.60	1.75	8.80	31.00	-0.20	-1.50	1.04	17.51	820.00	405.00	51.00
P08B	6/7/95	1.70	3.73	37.00	2.04	8.70	28.50	-0.20	-1.50	-0.50	12.10	831.00	73.00	25.00
P08B	9/6/95	0.97	3.30	36.60	2.32	8.30	45.90	-0.20	-1.50	-0.50	11.95	808.00	60.20	10.88
P08B	12/5/95		3.41				34.20		-1.50	-0.80	10.74		35.90	10.66
P08B	3/6/96	2.13	4.10	37.00	1.97	8.90	34.10	-0.20	1.85	-0.80	10.14	826.00	21.80	10.00
P08B	6/5/96	1.53	3.62	31.90	2.09	9.10	32.10	-0.20	-1.50	-0.80	10.35	862.00	118.70	7.00
P08B	9/6/96	1.19	3.50		2.31	8.90		-0.20	2.36	-0.80	10.01	793.00	34.30	9.90
P08B	12/5/96	3.13	5.14	33.50	2.01	9.10	35.90	-0.20	-1.50	-0.80	9.53	792.00	22.60	5.92
P08B	3/6/97	1.91	3.71	36.50	1.79	9.00	31.20	-0.20	-1.50	-0.80	12.00	848.00	54.10	29.70
P08B	6/5/97	1.81	3.94	35.70	2.13	9.10	33.60	-0.20	1.65	-0.80	10.90	872.00	41.60	5.35
P08B	9/4/97	2.37	4.36	32.90	1.99	9.10	33.90	-0.20	-1.50	-0.80		878.00	29.70	5.55
P08B	12/4/97													

Table E-9. Ground Water Quality at Station P10A in the Everglades Nutrient Removal Project.

STATION CODE	DATE	TEMP CENT.	D.O. MG/L	SP COND UMHOS/CM	PH UNITS	TURB NTU	NOX MG/ML	NO2 MG/ML	NH4 MG/ML	TKN MG/ML	CP04 MG P/L	TP04 MG P/L	SI02 MG/L	NA MG/L
P10A	12/7/94	24.40		1284	6.70	160.00	0.03	0.00	1.94	4.93	0.032	0.144	25.00	131.00
P10A	3/7/95	23.70		1247	6.76	140.00	0.00	0.00	2.55	5.35	0.036	0.169	27.60	127.00
P10A	6/7/95	23.10		1240	7.06	165.00	0.00	0.00	2.06	4.58	0.037	0.145	25.40	118.00
P10A	9/6/95	23.00		1221	6.82	9.40	0.01	0.00	2.18	3.85	0.038	0.088	25.10	117.37
P10A	12/5/95	23.90		1173	6.80		0.00	0.00		4.64	0.042	0.063	27.10	115.41
P10A	3/6/96	23.80		1140	6.83	3.70	0.00	0.00	2.31	4.45	0.024	0.035	24.90	105.64
P10A	6/5/96	24.60	0.10	1084	6.88	24.10	-0.02	0.00	2.08	1.51	0.027	0.034	135.50	96.83
P10A	9/6/96	23.20	0.20	968	6.57	39.60	-0.02	0.00	2.10	3.68	0.033	0.033	23.60	83.43
P10A	12/3/96													
P10A	12/3/96	23.90	0.40	1058	7.00	12.20	1.24	0.00	2.21	4.60	0.023	0.033	24.40	89.30
P10A	3/4/97	23.70	0.10	1096	6.98	68.40	0.00	0.01	2.17	4.27	0.005	0.031	26.50	96.40
P10A	6/3/97	23.20	0.00	1055	7.00	39.40		0.00	2.07	6.41	0.027	0.025	29.60	84.50
P10A	9/2/97	23.50	0.90	1024	6.69			0.00						100.00
P10A	12/4/97	23.80	1.30	1117	6.00									

STATION CODE	DATE	K MG/L	CA MG/L	MH/L	CL MG/L	SO4 MG/L	HARDNESS MG/L/CAO	SULFIDE MG/L	OXID P MIU VOL	TOTAL AL MICROG/L	ALKALINITY MG/L	%SAT. DO PERCENT	NO3 MG/ML	
P10A	12/7/94	9.45	112.00	31.20	149.60	12.70	408.00		-06.00	7742.00	411.70		0.02	
P10A	3/7/95	9.50	108.00	30.00	154.80	10.60	393.00		-35.00	7767.00	386.70		0.00	
P10A	6/7/95	9.10	102.00	29.00	160.30	10.50	374.00		-30.00	2032.80	376.90		0.00	
P10A	9/6/95	10.39	100.19	27.44	147.20	16.90	363.00		-69.00	4143.20	380.10		0.01	
P10A	12/5/96	11.38	103.57	28.03	141.40	-1.00	374.00		-70.00	6938.00			0.00	
P10A	3/6/96	11.13	97.47	26.21	143.00	6.90	351.00		-53.00	106.50	356.50		-0.02	
P10A	6/5/96	9.21	87.19	23.49	130.30	4.30	314.00		-297.00	404.60	359.90	1.00	-0.02	
P10A	9/6/96	7.46	89.00	24.64	127.40	5.80	324.00	13.00		1430.80	357.90	2.00	-0.02	
P10A	12/3/96							11.00						
P10A	12/3/96	9.80	98.10	26.70	129.60	6.10	355.00		-275.00	240.00	357.80	4.00	1.23	
P10A	3/4/97	10.90	101.00	27.40	132.00	6.40	365.00		-208.00	2230.00	442.90	1.00	-0.02	
P10A	6/3/97	10.70	96.79	26.10	108.50	5.40	348.00	18.00		389.00	355.60			
P10A	9/2/97	9.80	97.00	26.00										
P10A	12/4/97													

Table E-9. Ground Water Quality at Station PO10A in the Everglades Nutrient Removal Project (Continued).

STATION CODE	DATE MONTH	TOTAL N MG/L	TOTAL P MG/L	TDORCC MG/L	NO ₃ -N MG/L	AMMONIA MG/L	TDORCC MG/L	TOTAL HG MICROG/L	TOTAL AS MICROG/L	TOTAL PB MICROG/L	TOTAL BA MICROG/L	IDS SOL MG/L	TOFEE MICROG/L	TDSEE MICROG/L
P10A	12/7/94	2.89	4.85	40.20	1.97	8.20	47.40	-0.20	2.43	2.64	214.00	752.00	4466.00	34.00
P10A	3/7/95	2.82	5.37	44.60	2.55	7.70	52.00	-0.20	2.62	1.53	197.10	816.00	881.00	-20.00
P10A	6/7/95	2.54	4.60	43.20	2.06	7.50	37.10	-0.20	3.04	1.57	173.90	715.00	3970.00	21.00
P10A	9/8/95	1.67	3.86	41.10	2.19	7.60	50.50	-0.20	2.36	1.19	127.72	784.00	3390.00	9.92
P10A	12/5/95		4.64				37.10	0.30	2.37	1.92	120.86		4210.77	9.86
P10A	3/6/96	2.15	4.46	42.20	2.31	7.10	41.90	-0.20	-1.50	-0.80	89.96	699.00	63.60	7.10
P10A	6/5/96	-0.50	1.53	36.60	2.10	7.20	37.00	-0.20	-1.50	-0.80	82.80	685.00	255.80	11.10
P10A	9/6/96	1.59	3.70		2.11	7.20		-0.20	-1.50	-0.80	88.38	650.00	1147.10	48.00
P10A	12/3/96													
P10A	12/3/96	2.39	5.84	35.10	3.45	7.20	34.50	-0.20	-1.50	1.22	74.50	611.00	149.00	4.65
P10A	3/4/97	2.11	4.28	35.90	2.17	8.90	34.90	-0.20	1.79	-0.90	90.20	690.00	1280.00	10.90
P10A	6/3/97	4.34		32.40		7.10	33.60	-0.20	-1.50	-0.80	83.60	665.00	274.00	9.05
P10A	9/2/97													
P10A	12/4/97													

Table E-10. Ground Water Quality at Station P11A in the Everglades Nutrient Removal Project.

STATION CODE	DATE Mo/day/yr	TEMP CENT.	D.O. MG/L	SP COND UM/OS/CM	PH UNITS	TURB NTU	NOX MG/NL	NO2 MG/NL	NH4 MG/NL	TKN MG/NL	ORP4 MG/PIL	TP04 MG/PIL	SI02 MG/L	NA MG/L
P11A	12/6/94	24.00	580	6.87	88.00	0.01	0.00	1.17	9.75	0.018	0.717	31.50	115.00	
P11A	3/6/95	25.90	650	6.58	100.00	0.03	0.00	4.84	9.68	0.009	0.246	34.20	119.50	
P11A	6/6/95	24.30	540	6.76	675.00	0.00	0.00	5.48	8.98	-0.004	0.149	34.10	106.50	
P11A	9/6/95	24.10	560	6.61	29.00	0.05	0.00	8.46	6.64	0.006	0.075	31.60	96.41	
P11A	12/6/95	24.30	500	6.64	196.00	0.01	0.00	5.34	5.34	0.007	0.037	33.70	88.62	
P11A	3/7/96	24.90	520	6.74	129.00	0.38	0.00	4.82	5.48	0.014	0.039	29.50	106.01	
P11A	9/8/96	24.80	538	6.65	129.00	0.13	0.00	5.50	8.19	0.008	0.028	30.70	97.68	
P11A	12/5/96	25.70	610	6.75	4.70	0.18	0.01	5.08	8.33	-0.004	0.023	33.20	98.30	
P11A	3/8/97	24.50	622	6.88	14.00	0.07	0.00	5.41	9.45	0.004	0.004	32.60	126.00	
P11A	6/5/97	24.70	650	6.74	91.50	0.47	0.03	5.03	10.11	0.015	0.046	30.00	126.00	
P11A	9/4/97	25.80	562	6.69	91.50	0.47	0.03	5.03	10.11	0.015	0.046	30.00	126.00	
P11A	12/3/97	24.80	592	6.70										

STATION CODE	DATE Mo/day/yr	K MG/L	CA MG/L	MG MH/L	CL MG/L	S04 MG/L	HARDNESS MG/LCA/CO	SULFIDE MG/L	OXFRED P MILLI VOL	TOTAL AL MICROGAL	ALKALINITY MG/L	%SAT. DO PERCENT	NO3 MG/NL
P11A	12/6/94	11.35	137.00	67.40	201.70	34.00	620.00		-33.00	12154.00	506.90		0.01
P11A	3/6/95	10.95	133.00	67.50	207.00	28.20	610.00		-80.00	1797.00	1426.20		0.02
P11A	6/6/95	11.10	124.50	66.00	173.90	31.00	583.00		-9.00	5385.00	523.00		0.00
P11A	9/6/95	12.06	117.82	60.70	170.30	37.00	544.00		-2.00	72.30	488.60		0.05
P11A	12/6/95	12.89	120.94	61.05	170.90	32.50	553.00		-53.00	292.20	502.60		-0.02
P11A	3/7/96	13.27	124.13	65.80	157.10	32.60	581.00		-57.00	873.90	502.60		0.37
P11A	9/6/96	9.36	137.54	64.86	191.60	32.60	610.00	5.60	-289.00	434.20	522.60	3.00	0.13
P11A	12/5/96						678.00	6.10	-235.00	11600.00		4.00	
P11A	3/6/97	13.30	141.00	66.80	173.40	33.90	627.00		-185.00	98.10	539.60	4.00	0.17
P11A	6/5/97	9.65	106.00	52.50	184.00	32.30	481.00			1230.00	518.60	5.00	0.06
P11A	9/4/97	12.00	140.00	65.00	163.90	31.00		8.80		407.00	536.50	8.00	0.45
P11A	12/3/97							8.20					

Table E-10. Ground Water Quality at Station P11A in the Everglades Nutrient Removal Project (Continued).

STATION CODE	DATE	TKANNH MG/L	TOTAL N MG/L	TDORGC MGL	NO3NH4 MG/L	ALUMINUM MGL	TOTAL P MGL	TOTAL AS MICROG/L	TOTAL PB MICROG/L	TOTAL BA MGL	TDS SOL MGL	TOIFEI MICROG/L	TDSEFI MICROG/L
P11A	12/6/94	9.58	10.80	66.80	1.18	10.10	70.90	-0.20	15.14	4.96	250.30	979.00	7110.00
P11A	3/6/95	4.84	9.71	55.90	4.87	28.50	74.50	-0.20	8.56	1.28	186.11	1020.00	646.00
P11A	6/6/95	3.51	8.99	53.20	5.48	10.50	65.00	-0.20	6.55	0.53	121.70	1000.00	2910.00
P11A	9/6/95	-0.50	6.70	58.90	8.51	9.80	59.20	-0.20	-1.50	-0.50	78.18	892.00	53.70
P11A	12/6/95	0.65	5.05	49.80	5.20	10.10	29.90	-0.20	-1.50	-0.80	59.32	802.00	202.90
P11A	3/7/96	2.70	8.32		5.63	10.50	50.70	-0.20	1.88	1.56	66.15	795.00	605.80
P11A	12/5/96							-0.20	1.87	2.35	67.54		468.80
P11A	3/6/97	4.25	9.51	57.50	5.26	10.80	57.20	-0.20	4.79	-0.80	69.80	996.00	73.80
P11A	6/5/97	4.04	9.52	59.00	5.48	10.40	59.50	-0.20	2.82	1.04	77.70	921.00	817.00
P11A	9/4/97	5.08	10.60	53.70	5.51	10.70	53.80	-0.20	-1.50	-0.80		868.00	267.00
P11A	12/3/97												18.10

Table E-11. Ground Water Quality at Station P12A in the Everglades Nutrient Removal Project.

STATION CODE	DATE Mo/day/yr	TEMP CENIT	D.O. MG/L	SP COND UMHS/CM	PH UNITS	TURB NTU	NOX MG/NL	NO2 MG/NL	NHA MG/NL	TKN MG/NL	OP04 MG P/L	TP04 MG P/L	SI02 MG/L	NA MG/L
P12A	12/7/94	23.70		1470	6.60	205.00	0.61	0.00	1.55	4.64	0.017	0.120	28.70	145.00
P12A	3/7/95	23.00		1420	6.71	205.00	0.00	0.00	1.57	4.72	0.020	0.083	29.30	151.50
P12A	6/7/95	23.00		1348	7.02	185.00	0.00	0.00	1.46	4.09	0.018	0.053	27.90	133.00
P12A	9/6/95	23.10		1287	6.81	38.00	0.00	0.00	1.61	3.45	0.018	0.027	25.50	130.00
P12A	12/5/95	23.00		1237	6.83		0.00	0.00	1.61	3.74	0.018	0.032	26.60	122.68
P12A	3/6/96	22.70		1248	6.82	17.70	0.00	0.00	1.85	3.94	0.012	0.019	26.60	117.65
P12A	6/5/96	23.30	0.00	1202	6.84	39.00	-0.02	0.00	1.46	1.45	0.015	0.030	147.60	104.72
P12A	9/4/96	24.50	0.30	1032	7.04	8.10	-0.02	0.00	1.58	3.24	0.014	0.040	25.30	94.38
P12A	12/3/96													
P12A	12/3/96	23.60	0.40	1041	7.05	14.80	0.00	0.00	1.90	3.72	0.015	0.022	25.60	81.30
P12A	3/4/97	22.90	0.20	1139	7.00	16.90	0.00	0.01	1.54	3.21	0.005	0.013	27.00	94.30
P12A	6/3/97	23.70	0.00	1152	6.97	18.20		0.00	1.57	4.46	0.013	0.009	36.30	83.10
P12A	9/2/97	23.70	1.20	1084	6.83									110.00
P12A	12/4/97	23.00	1.70	1170	6.92									

STATION CODE	DATE Mo/day/yr	K MG/L	CA MG/L	MH MG/L	CL MG/L	SO4 MG/L	HARDNESS MG/LCAO	SULFIDE MG/L	OXRED P ML/VOL	TOTAL AL MICROG/L	ALKALINITY MG/L	%SAT. DO PERCENT	NO3 MG/NL	
P12A	12/7/94	11.05	141.00	36.30	198.20	15.90	501.00			6668.00	474.10		0.00	
P12A	3/7/95	11.00	124.00	36.50	178.60	10.30	456.00		-108.00	1899.00	443.30		0.00	
P12A	6/7/95	10.10	110.00	32.00	157.60	8.90	406.00		-33.00	861.00	431.60		0.00	
P12A	9/6/95	11.34	103.76	28.79	155.90	16.40	378.00		-30.00	2283.20	406.60		0.00	
P12A	12/5/95	11.80	106.34	29.22	147.60	-1.00	386.00		-82.00	1414.20			0.00	
P12A	3/6/96	11.60	108.74	29.97	150.20	6.00	385.00		-64.00	204.50	406.50		-0.02	
P12A	6/5/96	9.67	97.20	26.39	137.80	4.50	361.00		-37.00	371.60	417.20	0.00	-0.02	
P12A	9/4/96	8.49	99.76	28.48	106.20	-1.00	366.00	13.00	-304.00	95.10	380.90	4.00	-0.02	
P12A	12/3/96							12.00						
P12A	12/3/96	9.52	101.00	26.80	117.30	8.50	363.00		-284.00	188.00	361.80	5.00	-0.02	
P12A	3/4/97	10.90	114.00	32.10	128.10	5.60	417.00		-195.00	143.00	394.90	2.00	-0.02	
P12A	6/3/97	10.80	110.00	29.70	116.30	4.80	397.00			286.00	400.90			
P12A	9/2/97	10.00	110.00	31.00				16.00						
P12A	12/4/97							12.00						

Table E-11. Ground Water Quality at Station P12A in the Everglades Nutrient Removal Project (Continued).

STATION CODE	DATE	TOTAL NITROGEN	TOTAL PHOSPHORUS	TOTAL AMMONIUM NITROGEN	ALUMINUM	TOTAL CHLORIDE	TOTAL SULFATE	TOTAL SILICATE	TOTAL BORON	TOTAL IRON	TOTAL MANGANESE	TOTAL ZINC	TOTAL CADMIUM	TOTAL COPPER	TOTAL CHROMIUM	TOTAL NICKEL	TOTAL SELENIUM	TOTAL FLUORIDE	TOTAL CHLORIDE	TOTAL SULFATE	TOTAL BORON	TOTAL IRON	TOTAL MANGANESE	TOTAL ZINC	TOTAL CADMIUM	TOTAL COPPER	TOTAL CHROMIUM	TOTAL NICKEL	TOTAL SELENIUM			
	Mo/yy	MG/L	MG/L	MG/L	MG/L	MG/L	MG/L	MG/L	MG/L	MG/L	MG/L	MG/L	MG/L	MG/L	MG/L	MG/L	MG/L	MG/L	MG/L	MG/L	MG/L	MG/L	MG/L	MG/L	MG/L	MG/L	MG/L	MG/L	MG/L			
P12A	12/7/94	3.09	4.64	1.56	9.50	54.50	-0.20	2.53	2.20	265.40	949.00	4860.00	70.00																			
P12A	3/7/96	3.16	4.73	1.57	8.90	52.70	-0.20	5.20	1.72	219.40	927.00	4360.00	-20.00																			
P12A	6/7/95	2.63	4.09	1.47	8.60	41.60	-0.20	3.80	0.66	149.60	896.00	373.00	-20.00																			
P12A	9/6/95	1.83	3.45	1.62	8.10	57.70	0.30	3.41	1.21	117.57	822.00	550.50	-3.00																			
P12A	12/5/95		3.74			37.10	-0.20	2.81	-0.80	101.60		1232.84	-3.00																			
P12A	3/6/96	2.09	3.95	1.86	8.20	43.30	-0.20	1.89	-0.80	97.75	767.00	154.80	7.70																			
P12A	6/5/96	-0.50	1.46	1.47	8.30	38.30	-0.20	1.65	-0.80	88.22	744.00	359.40	13.50																			
P12A	9/4/96	1.66	3.25	1.59	7.60		-0.20	-1.50	-0.80	79.63	712.00	88.40	4.70																			
P12A	12/3/96																															
P12A	12/3/96	1.82	3.73	1.91	7.20	33.30	-0.20	2.20	-0.80	75.00	586.00	140.00	6.18																			
P12A	3/4/97	1.67	3.21	1.54	7.90	33.20	-0.20	-1.50	-0.80	84.10	693.00	95.90	7.06																			
P12A	6/3/97	2.89			8.00	34.10	-0.20	-1.50	-0.80	89.10	708.00	246.00	3.66																			
P12A	9/2/97																															
P12A	12/4/97																															

Table E-12. Ground Water Quality at Station P13A in the Everglades Nutrient Removal Project.

STATION CODE	DATE	TEMP CENT	D.O. MG/L	SP COND UM/HOS/CM	PH UNITS	TURB NTU	NOX MG/NL	NO2 MG/NL	NH4 MG/NL	TKN MG/NL	OP04 MG/PIL	TP04 MG/PAL	SI02 MG/L	NA MG/L
P13A	12/7/94	23.30	1378	6.70	22.00	0.01	0.00	1.20	3.45	0.007	0.026	25.10	133.00	
P13A	3/7/95	22.80	1367	6.73	280.00	0.00	0.00	1.24	4.35	0.011	0.125	27.90	133.50	
P13A	6/7/95	23.00	1316	6.81	75.50	0.00	0.00	1.26	3.99	0.010	0.078	28.10	128.00	
P13A	9/6/95	23.30	1281	6.80	6.00	0.01	0.00	1.30	3.08	0.011	0.010	25.90	124.84	
P13A	12/5/95	22.90	1225	6.77	9.70	0.00	0.00	1.43	2.78	0.016	0.015	23.50	120.61	
P13A	3/6/96	23.10	1249	6.80	1.90	-0.02	0.00	1.13	3.48	0.005	0.011	26.70	116.14	
P13A	6/3/96	22.80	1153	6.95	6.40	-0.02	0.00	1.29	3.73	0.006	0.011	144.00	105.21	
P13A	9/4/96	24.50	1066	7.00	4.30	0.09	0.00	1.53	2.99	0.011	0.015	24.20	95.96	
P13A	12/3/96	23.90	1072	7.00	48.40	0.01	0.01	1.29	3.53	0.010	0.005	24.30	87.30	
P13A	3/4/97	23.50	1138	6.98	7.00	0.00	0.00	1.16	3.69	-0.004	0.018	27.40	101.00	
P13A	6/3/97	24.30	1135	6.94					3.78	-0.004	-0.004	29.70	85.50	
P13A	9/2/97	23.70	1067	5.75									119.00	
P13A	12/3/97	23.10	1131	5.87										

STATION CODE	DATE	TEMP CENT	CA MG/L	MG MHL	CL MG/L	S04 MG/L	HARDNESS MG/LCAO	SULFIDE MG/L	OXFRED P ML/VOL	TOTAL AL MICROGR/L	ALKALINITY MG/L	%SAT. DO PERCENT	NO3 MG/NL
P13A	12/7/94	9.40	124.00	35.00	172.10	15.10	454.00			172.80	417.50		0.01
P13A	3/7/95	8.45	117.00	32.50	168.20	10.60	426.00	-106.00		4754.00	431.30		0.00
P13A	6/7/95	8.60	108.50	32.00	153.30	8.50	403.00	-28.00		1193.00	423.00		0.00
P13A	9/6/95	10.06	104.82	28.97	156.30	15.10	381.00	-49.00		165.70	389.60		0.00
P13A	12/5/95	10.42	106.82	29.45	133.80	-1.00	388.00	-70.00		90.60	368.90		0.00
P13A	3/6/96	10.38	108.99	30.26	154.30	7.60	397.00	-73.00		94.50	368.90		-0.02
P13A	6/3/96	9.25	96.98	25.53	138.50	4.70	351.00	-363.00		34.10	387.60	-2.00	-0.02
P13A	9/4/96	8.24	103.67	25.61	109.20	-1.00	377.00	-340.00		60.50	372.60	4.00	-0.02
P13A	12/3/96							11.00					
P13A	12/3/96	8.71	102.00	27.30	123.70	6.70	367.00	-288.00		73.90	368.60	6.00	0.08
P13A	3/4/97	10.10	114.00	31.90	131.10	6.40	416.00	-216.00		559.00	411.60	0.00	-0.02
P13A	6/3/97	10.00	107.00	28.60	113.40	4.70	385.00	18.00		70.50	389.10		
P13A	9/2/97	9.30	110.01	30.00				12.00					
P13A	12/3/97												

Table E-12. Ground Water Quality at Station P13A in the Everglades Nutrient Removal Project (Continued).

STATION CODE	DATE	TRNH4	TOTALN	TDORG	NO3NH4	ALKALINM	TOTOPC	TOTALIG	TOTALAS	TOTALPB	TOTALBA	TDS SOL	TOTFEI	JDSFEI
	Mo/day	MG/L	MG/L	MG/L	MG/L	MG/L	MG/L	MG/OG/L	MG/OG/L	MG/OG/L	MG/OG/L	MG/L	MG/OG/L	MG/OG/L
P13A	12/7/94	2.26	3.46	40.50	1.21	8.40	41.30	-0.20	1.51	-0.50	218.80	864.00	398.00	-20.00
P13A	3/7/95	3.11	4.35	46.80	1.24	8.60	49.60	-0.20	12.78	1.29	244.60	896.00	4730.00	-20.00
P13A	6/7/95	2.74	4.00	49.80	1.26	9.50	38.40	0.20	15.95	1.83	229.80	851.00	7880.00	-20.00
P13A	9/6/95	1.78	3.08	57.60	1.30	7.80	55.00	-0.20	2.15	-0.50	149.21	791.00	93.30	-3.00
P13A	12/5/95		2.78				33.80		1.76	-0.80	129.18		75.50	4.50
P13A	3/6/96	2.05	3.48	43.20	1.43	8.00	42.20	-0.20	1.71	-0.80	130.77	764.00	67.90	19.10
P13A	6/3/96	2.61	3.75	39.60	1.14	7.90	57.40	-0.20	-1.50	-0.80	109.58	732.00	52.00	-3.00
P13A	9/4/96	1.70	3.01		1.31	7.40		-0.20	-1.50	-0.80	114.97	684.00	74.70	-3.00
P13A	12/3/96													
P13A	12/3/96	2.00	3.62	33.30	1.62	7.40	32.00	-0.20	1.53	-0.80	101.00	659.00	78.30	5.45
P13A	3/4/97	2.40	3.70	34.00	1.30	8.20	33.80	-0.20	-1.50	-0.80	119.00	733.00	455.00	11.20
P13A	6/9/97	2.62		33.80		7.80	33.70	-0.20	-1.50	-0.80	120.00	724.00	76.60	-3.00
P13A	9/2/97													
P13A	12/3/97													

Table E-13. Ground Water Quality at Station P14B in the Everglades Nutrient Removal Project.

STATION CODE	DATE	TEMP CENT.	PH	TURB NTU	NOX MG/NL	NO2 MG/NL	NH4 MG/NL	TKN MG/NL	CP04 MG P/L	TP04 MG P/L	SI02 MG/L	NA MG/L
P14B	12/7/94	23.70	6.78	5.40	0.00	0.00	1.92	3.86	0.042	0.069	29.00	125.00
P14B	3/7/95	24.00	6.87	10.40	0.00	0.00	1.79	4.30	0.028	0.043	26.10	119.50
P14B	6/7/95	23.50	7.08	3.10	0.00	0.00	1.62	4.01	0.038	0.040	26.50	115.00
P14B	9/6/95	23.80	6.91	1.50	0.02	0.00	2.13	3.51	0.04	0.034	27.10	117.72
P14B	12/5/95	23.70	6.73		0.00	0.00		4.30	0.032	0.040	25.00	113.49
P14B	3/6/96	23.90	6.91	4.80	0.00	0.00	2.02	3.32	0.019	0.026	27.30	108.91
P14B	6/5/96	23.30	6.96	10.90	-0.02	0.00	1.80	1.09	0.032	0.04	137.90	87.75
P14B	9/6/96	23.20	6.94	3.80	-0.02	0.00	1.91	2.99	0.037	0.046	25.70	85.42
P14B	12/5/96	23.10	7.01	3.30	0.01	0.00	1.71	4.91	0.029	0.026	25.80	99.40
P14B	3/6/97	23.30	7.09	97.00	0.01	0.01	1.78	3.55	0.016	0.036	27.30	84.70
P14B	6/5/97	23.10	7.07	40.90	0.01	0.00	1.80	3.78	0.037	0.058	24.00	83.40
P14B	9/4/97	23.10	7.00	45.40	0.01	0.01	1.78	4.17	0.026	0.054	25.80	100.00
P14B	12/4/97	23.00	6.95									

STATION CODE	DATE	K MG/L	CA MG/L	MH MG/L	CL MG/L	SO4 MG/L	HARDNESS MG/LCAO	SULFIDE MG/L	OXFRED P MILLI VOL	TOTAL AL MICROG/L	ALKALINITY MG/L	%SAT. DO PERCENT	NO3 MG/NL
P14B	12/7/94	9.60	109.00	31.90	167.40	16.10	403.00		-89.00	339.20			0.00
P14B	3/7/95	9.40	101.00	23.50	149.60	15.20	374.00		-104.00	46.60	360.30		0.00
P14B	6/7/95	9.05	99.00	23.00	163.90	21.80	367.00		-39.00	-2.50	349.60		0.00
P14B	9/6/95	10.30	97.49	27.72	144.60	23.90	358.00		-31.00	22.50	360.40		0.00
P14B	12/5/95	11.13	93.61	26.54	142.80	-1.00	343.00		-72.00	66.70		15.00	0.00
P14B	3/6/96	10.91	96.72	27.38	136.30	11.50	364.00		-68.00	21.30	289.40		-0.02
P14B	6/5/96	8.67	80.66	22.39	122.20	10.40	294.00		-25.00	415.10	361.30		-0.02
P14B	9/6/96	7.67	91.90	26.32	131.90	11.70	336.00	14.00	-336.00	110.80	329.30		-0.02
P14B	12/5/96	8.81	98.00	28.20	128.20	9.80	361.00	14.00	-309.00	35.10	349.40		-0.02
P14B	3/6/97	10.70	97.70	27.00	129.50	11.80	355.00		-229.00	740.00	361.20		-0.02
P14B	6/5/97	10.00	93.50	26.30	109.00	10.10	342.00			540.00	319.70		-0.02
P14B	9/4/97	9.40	96.00	27.00	133.80	9.60		24.00		771.00	347.90		-0.02
P14B	12/4/97							14.00					

Table E-13. Ground Water Quality at Station P14B in the Everglades Nutrient Removal Project (Continued).

STATION CODE	DATE	TKNH4 MG/L	TOTAL N MG/L	TDORG MGL	NO3NH4 MG/L	ALUMINUM MGL	TOTOC MGL	TOTAL P MCG/L	TOTAL AS MCG/L	TOTAL BA MCG/L	TDS SOL MGL	TOFEI MCG/L	TDSEFI MCG/L
P14B	12/7/94	1.94	3.86	50.70	1.93		41.70	-0.50	1.78	114.10	823.00	143.00	-20.00
P14B	3/7/96	2.50	4.30	45.90	1.80	7.20	43.80	-0.50	1.74	124.01	768.00	73.00	-20.00
P14B	6/7/96	2.39	4.01	43.40	1.63	7.00	14.20	-0.50	1.87	161.40	767.00	23.00	-20.00
P14B	9/6/96	1.39	3.53	37.20	2.14	7.20	56.40	-0.50	-1.50	61.50	779.00	13.90	-3.00
P14B	12/5/96		4.31				40.70	0.87	-1.50	52.61		61.70	3.52
P14B	3/6/96	1.30	3.32	43.10	2.02	5.80	41.90	-0.80	-1.50	42.76	698.00	15.00	-3.00
P14B	6/5/96	-0.50	1.11	34.90	1.81	7.20	36.80	-0.80	1.90	43.64	710.00	252.70	4.30
P14B	9/6/96	1.08	3.01		1.92	6.60		-0.80	-1.50	42.71	591.00	86.10	-3.00
P14B	12/5/96	3.10	4.82	35.20	1.72	7.00	36.10	2.90	-1.50	37.90	634.00	24.50	-3.00
P14B	3/6/97	1.78	3.56	39.50	1.78	7.20	33.10	4.10	4.21	92.10	683.00	5350.00	37.20
P14B	6/5/97	1.97	3.78	33.40	1.81	6.40	33.80	-0.80	2.43	40.30	652.00	433.00	8.20
P14B	9/4/97	2.39	4.18	32.10	1.78	6.90	32.00	-0.80	-1.50		643.00	566.00	7.60
P14B	12/4/97												

