

I 29.95:T-544

DEPOSITORY

SOUTH FLORIDA RESEARCH CENTER

Report T-544

An Application of LANDSAT Multispectral Imagery for the Classification of Hydrobiological Systems, Shark River Slough



Everglades National Park, South Florida Research Center, P.O. Box 279, Homestead, Florida 33030



AN APPLICATION OF LANDSAT MULTISPECTRAL IMAGERY
FOR THE CLASSIFICATION OF HYDROBIOLOGICAL SYSTEMS
SHARK RIVER SLOUGH, EVERGLADES NATIONAL PARK, FLORIDA

Report T-544

Paul W. Rose and Peter C. Rosendahl

U.S. National Park Service
South Florida Research Center
Everglades National Park
Homestead, Florida 33030

Rose, Paul W. and Peter C. Rosendahl. 1979. An Application of LANDSAT
Multispectral Imagery for the Classification of Hydrobiological Systems,
Shark River Slough, Everglades National Park, Florida. South Florida
Research Center Report T-544. 65 pp.

AN APPLICATION OF LANDSAT MULTISPECTRAL IMAGERY
FOR THE CLASSIFICATION OF HYDROBIOLOGICAL SYSTEMS
SHARK RIVER SLOUGH, EVERGLADES NATIONAL PARK, FLORIDA

Report T-544

Paul W. Rose and Peter C. Rosendahl

U.S. National Park Service
South Florida Research Center
Everglades National Park
Homestead, Florida 33030

Rose, Paul W. and Peter C. Rosendahl. 1979. An Application of LANDSAT Multispectral Imagery for the Classification of Hydrobiological Systems, Shark River Slough, Everglades National Park, Florida. South Florida Research Center Report T-544. 65 pp.

ABSTRACT

The hydrologic balance of the Florida Everglades directly influences all ecological aspects of the region. This intricate ecosystem is dependent on freshwater supplies which must be furnished in sufficient quantity and at appropriate rates to achieve ecosystem maintenance. Orbital remote sensing satellites (LANDSAT A, B, and C) have provided a comprehensive and repetitive survey of the multi-variant hydrologic parameters over both the accessible and inaccessible regions of Everglades National Park. LANDSAT multispectral data were analyzed for application to the Shark River Slough in Everglades National Park. The procedure was systematic establishing "ground truth" utilizing conventional high flight aerial U-2 infrared photography and comprehensive field data. These procedures enabled a control network to be defined which represented all hydrobiological systems in the slough. These data were then directly applied to the LANDSAT imagery utilizing an interactive multispectral processor which generated hydrographic maps through classification of the slough and defined the multispectral surface radiance characteristics of the wetlands areas in the park. The spectral response of each hydrobiological zone was determined and plotted. The spectral relationships plots provided utility in formulating multispectral relationships between the emittent energy from the slough in order to determine the best possible multispectral wavelength combinations to enhance classification results. The resultant classification was of paramount importance in determining the extent of each hydrobiological zone in

ABSTRACT

the Shark Slough and in establishing flow vectors for water movement throughout the slough. The application of hydrologic remotely sensed data will provide greater utility in formulating a sounder water resources management program for Everglades National Park.

ACKNOWLEDGEMENTS

We would like to acknowledge the contributions made to this research by the National Aeronautics and Space Administration (NASA), Kennedy Space Center, for supplying both the hardware and software to accomplish this research; especially to Dr. Reed Barnett, Mr. Roy Bland and Mr. Bob Butterfield, we extend our appreciation.

In addition, we would like to thank Mr. Kirk Hipps for assisting with the flow direction studies conducted in the Shark Slough.

Finally, we would like to extend our gratitude to Dottie Anderson for manuscript formulation.

TABLE OF CONTENTS

ABSTRACT	i
ACKNOWLEDGEMENTS	iii
TABLE OF CONTENTS	iv
LIST OF FIGURES	v
LIST OF TABLES	vii
I. INTRODUCTION	1
II. SETTING	5
A. Shark River Slough	7
B. Earth-Sun Relationships	11
III. METHODOLOGY	19
A. Study Area	19
B. Aerial Photo Analysis	26
C. Computer Applications	32
1. Acquisition of ENP LANDSAT Data	34
2. Training	39
3. Accuracy Assessment	41
IV. SIGNIFICANT RESULTS	42
A. Shark Slough's LANDSAT Signatures	43
B. Hydrobiological Histograms and Statistics	45
C. Spectral Relationships in a Wetland Environ	47
D. Hydrobiological Classification of the Shark River Slough	53
E. Accuracy Assessment	61
F. Determination of Conceptual Flow Vectors for the Shark River Slough	63
V. CONCLUSION	66
REFERENCES	69

LIST OF FIGURES

<u>Figure</u>		
1	LANDSAT Components	3
2	LANDSAT Orbital Track	4
3	Everglades National Park Location	6
4	Surface Flow to Everglades National Park	8
5	Relationship of Timing of Wood Stork Nesting in Southern Everglades to Hydrologic Conditions	10
6	Wildlife Ecological Model of the Shark River Slough, Florida	10
7	Elevation of the Noon Sun above Shark River Slough (N25° 30' latitude)	12
8	Interaction of Energy with Water	15
9	Interaction of Green and Blue-Green Energy with Water	15
10	Interaction of Infrared Energy with Water	16
11	Relationship of Reflected Solar Radiation with Wavelength for Different Concentrations of Suspended Sediments in the Surface Water	18
12	Flow Diagram of ENP-Shark Slough Remote Sensing Hydro- biological System Program	20
13	Shark River Slough, Everglades National Park	21
14	Transect Location, Shark River Slough	24
15	Rhodamine Tracer Dye (Concentration vs. Time) Curves	26
16	Transect Profile, Shark River Slough.	27
17	Flow Diagram for Classification of LANDSAT-CCT Utilizing G.E.-I-100 Processor	36
18	LANDSAT Signatures of Shark Slough	42
19	Spectral Reflectance Plots for Shark Slough's Hydrobiological Zones	49

Figure

20	MSS-7 vs. MSS-5 Mean Reflectance Values Separating all Hydrobiological Zones, Shark River Slough	52	Figure
21	Selected Test Sites in Shark River Slough for Surface Flow Determinations	59	1
22	Direction of Surface Water Flow Measured in Shark Slough	59	2
23	Conceptual Flow Vectors for Surface Flow in Shark Slough	60	3
			4
			5
10			6
10			7
12			8
12			9
12			10
16			11
18			12
20			13
21			14
24			15
25			16
27			17
36			18
42			19
49			20

LIST OF TABLES

Tables

1	Multispectral Wavelengths Recorded by LANDSAT	2
2	Acceptable ERTS/LANDSAT Coverage Dates for ENP	35
3	March 3, 1975 Hydrologic Data Corresponding to LANDSAT Overflight	37
4	Hammocks: Histograms and Statistics	46
5	Open Marsh: Histograms and Statistics	48
6	Tall Sawgrass: Histograms and Statistics	49
7	Intermediate Sawgrass: Histograms and Statistics	50
8	Dry Season Classification Results for each Hydrobiological System, Shark Slough	60
9	Overall Classification Accuracy for each Hydrobiological Zone in Shark Slough	62

I. INTRODUCTION

The hydrologic balance of the Florida Everglades directly influences all ecological aspects of the region. This intricate ecosystem is dependent on freshwater supplies originating from both precipitation and surface water inflows which must be furnished in sufficient quantity and at appropriate rates to achieve ecosystem maintenance. Therefore, an intensive program of water management is mandatory if the quality of the Everglades is to be preserved.

Because of economic and time elements a comprehensive or repetitive survey of the hydrologic parameters over large areas is not always feasible utilizing conventional ground-based methods. However, orbital remote sensing satellites have in the past, provided a significant amount of scientific information and data regarding hydrologic conditions in both accessible and inaccessible regions.

One system, LANDSAT (formerly the ERTS program), has provided valuable insight into the hydrological characteristics of regions throughout the world (Figure 1). The first LANDSAT (ERTS-1) was launched on July 23, 1972 into a circular sun-synchronous orbit at an altitude of 900 km (580 miles) above the earth.

Two other LANDSAT satellites have been subsequently launched while the first LANDSAT has been discontinued. These satellites rotate about the earth every 103 minutes, complete fourteen orbits per day and repeat a given orbital track every eighteen days (Figure 2). Aboard the LANDSAT satellites is a package of scientific instruments consisting of a multispectral scanning device which records light in four distinct bands (Table 1).

I. INTRODUCTION

Table 1. Multispectral Wavelengths Recorded by LANDSAT.

Band	Wavelength of Light	Light Color
MSS-4	0.5 to 0.6 μm	Green
MSS-5	0.6 to 0.7 μm	Red
MSS-6	0.7 to 0.8 μm	near Infrared
MSS-7	0.8 to 1.1 μm	far Infrared

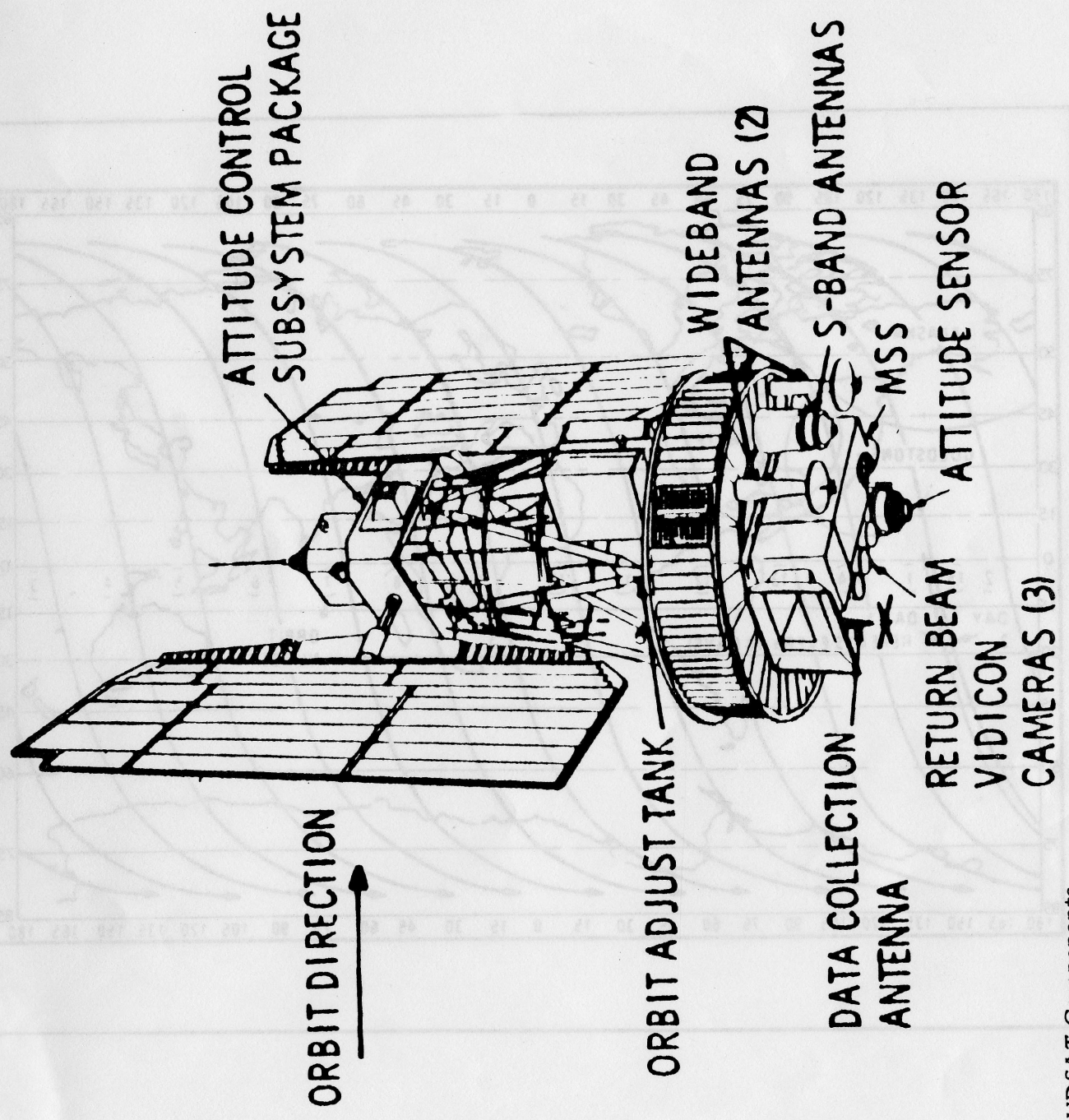

Figure 1. LANDSAT Components

Figure 5. LANDSAT Optical Track

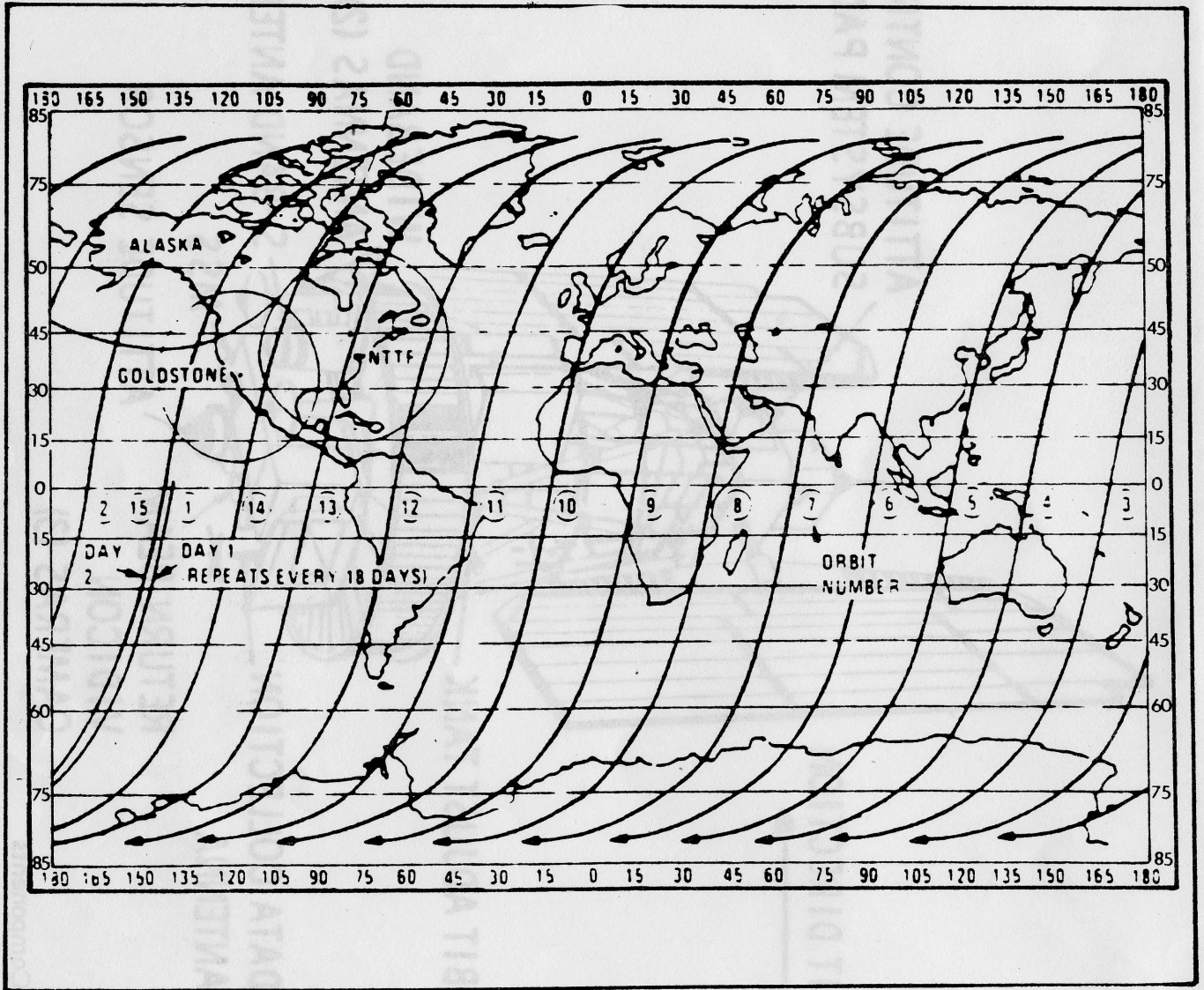

Figure 2. LANDSAT Orbital Track

The purpose of this research was to apply LANDSAT multispectral data to the Shark River Slough in Everglades National Park, Florida. A systematic "ground truth" was established utilizing comprehensive hydrologic field data and conventional high flight infrared aerial photography. A control network was defined which represented all hydrobiological zones in the Shark River Slough. These data were then directly applied to the LANDSAT imagery utilizing an interactive multispectral processor which generated hydrographic maps of the slough and defined the multispectral surface radiance characteristics of each hydrobiological system. It was the intent through the application of remotely sensed data, to provide greater utility in the formulation of a sound water resources management program for Everglades National Park which will ultimately benefit the park's ecosystem and the park experience for the visitor.

II. SETTING

Everglades National Park is situated at the southern terminus for the State of Florida (Figure 3). The park is a vast subtropical wilderness area located between the geographic coordinates $N24^{\circ} 50' 05''$ and $N25^{\circ} 50' 20''$ latitude and $W80^{\circ} 20' 20''$ and $W81^{\circ} 30' 10''$ longitude. The park's ecosystem consists of a marsh environment which is inundated throughout much of the year.

Surface water is one of the most prominent and characteristic natural features in south Florida. The mechanism for overland sheet flow is enacted following sufficient inputs of rainfall into the hydrologic regime. The surface water slowly inundates the flat, broad plain of the Everglades as a thin film. Even though the depth is not of great extent, the impact is widespread and life flourishes throughout the area.

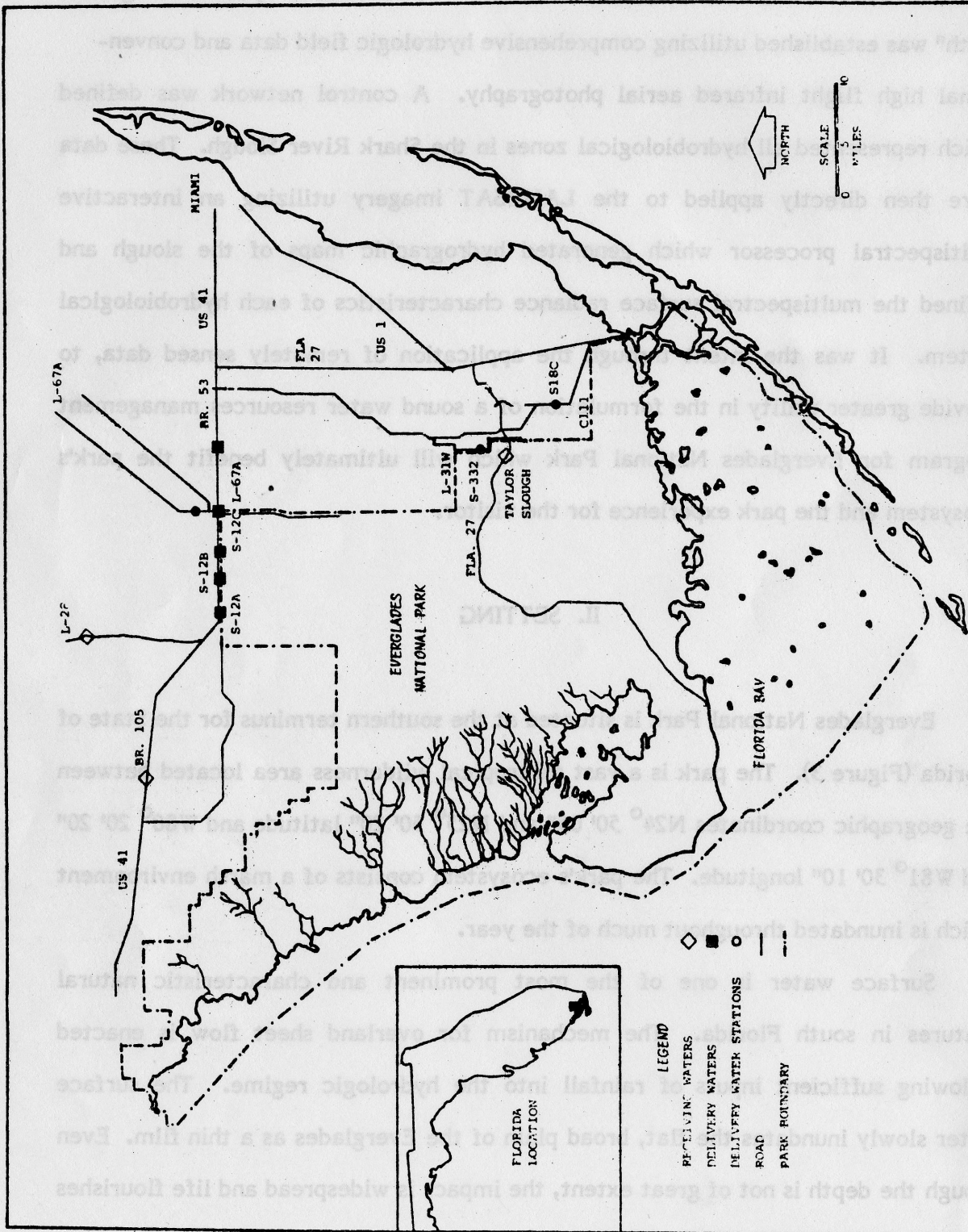

Figure 3. Everglades National Park Location

Shark River Slough

The Shark River Slough can be described as a low lying drainage area representing a mixture between a very wide river channel and a swamp which accommodates overland sheet flow of surface waters. The slough serves as a major arterial for surface water movement through the central portion of Everglades National Park. It is the lifestream for much of the park. The Shark Slough depends upon rainfall and allocations of water released through control structures outside Everglades National Park to provide input into its channel.

Throughout recent times the hydrologic conditions within Everglades National Park have been directly influenced by a modified hydrologic regime from external forces. The sheet flow into the park was interrupted and diverted as early as the 1920's when the Tamiami Trail (U.S. 41) and the associated adjacent Tamiami Canal was constructed.

Throughout the years which followed both Dade and Broward Counties continued to experience a rapid growth trend which necessitated the drainage of even more wetland areas outside of the present park boundary. At the expense of the natural wetlands, South Florida (including Everglades National Park) no longer experienced a natural overland sheet flow and hydrologic balance throughout the Everglades ecosystem (from Lake Okeechobee to Florida Bay) (Figure 4) due to pressures to develop various flood control and water supply projects. The altered hydrologic regime, combined with a severe drought, resulted in a mandate from the U.S. Congress which guaranteed a minimum delivery of surface waters into the Shark River Slough in Everglades National Park.

The amount of water released into the Shark River Slough is in accordance with Public Law 91-282 enacted by Congress in 1970. One of the provisions of the law provided for the minimum delivery of 260,000 acre feet (320.58 hm^3) of water per annum to the Shark Slough via four control structures on a monthly schedule.

The Shark River Slough can be described as a low lying drainage area representing a mixture between a very wide river channel and a swamp which

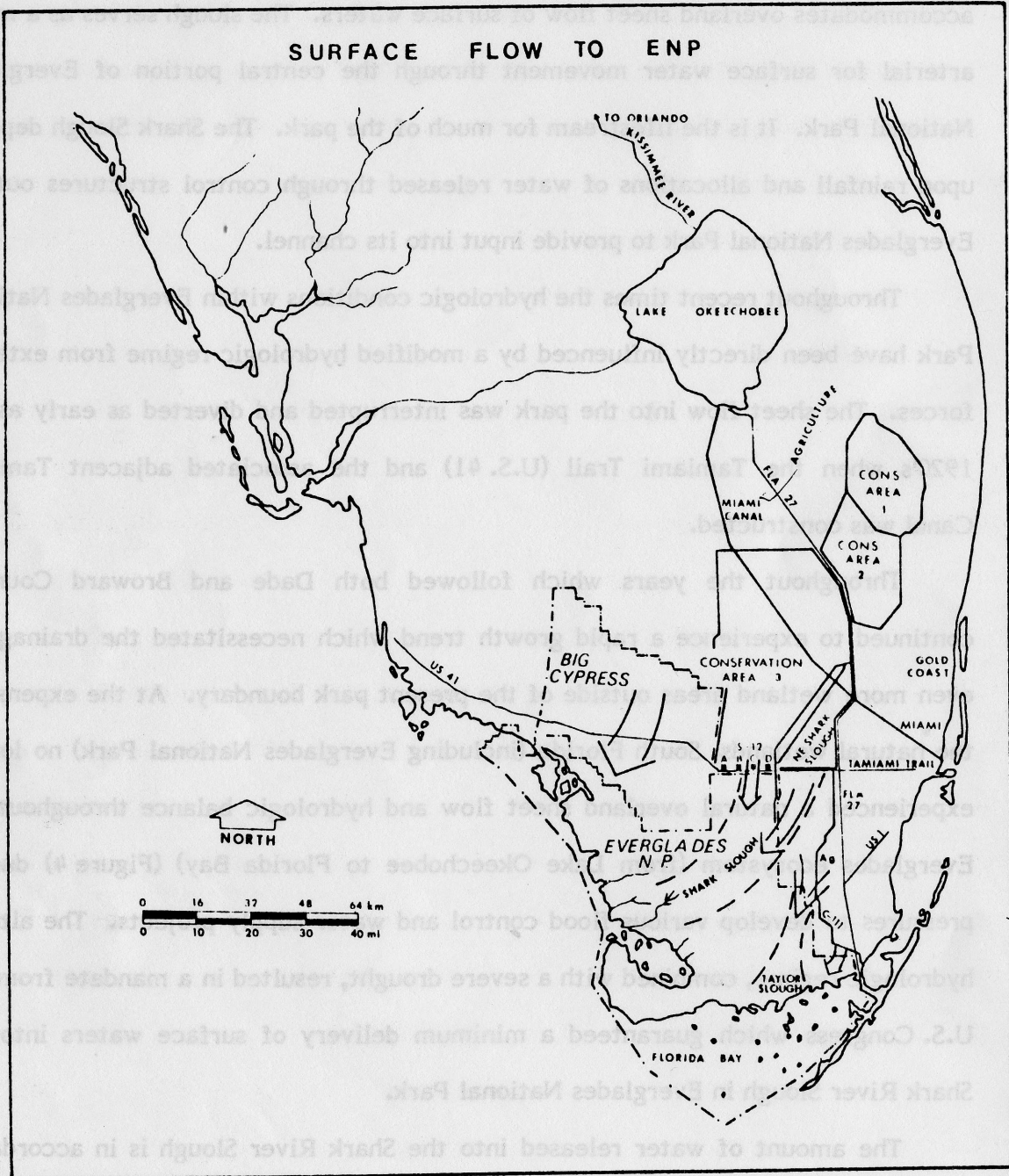

Figure 4. Surface Flow to ENP

The amount of water released into the Shark River Slough is in accordance with Public Law 91-282 enacted by Congress in 1970. One of the provisions of the law provided for the minimum delivery of 250,000 acre feet (250,000,000,000 gallons) of water per annum to the Shark Slough via four control structures on a monthly schedule.

These water deliveries to the park have attempted to approach the natural overland sheet flow the Shark Slough once experienced. However, due to uncertainties as to how well these controlled deliveries approximate natural flow rates, it became mandatory to closely monitor the slough's hydrologic regime.

Remotely sensed data provided a means whereby water conditions throughout the park were both spatially and temporally analyzed while permitting point definition. This can be of significance in providing some insight into hydrologic status of the slough and assisting with the generation of ecological models for the Everglades.

For example, the Wood Stork was reported to be a prime indicator of ecological stability and health in a wetlands area such as the Everglades (Kushlan, 1975). In recent times, the population of Wood Storks has experienced an overall decline. It was demonstrated that a change in the hydrologic regime in Everglades National Park associated with the development of south Florida, affected both the feeding habitat and food production of the Wood Stork. The net result was a decline in the Wood Stork population due to late colony formation combined with an interruption in Wood Stork nesting. It was also found that the timing of the colony formation/nesting could be correlated to water level fluctuation and recession rate during the dry season affecting the nutritional state of the marsh. During the nesting months, a slow water level recession/drying rate is responsible for a slow food (fish) concentration which in turn delays rookery formation and nesting (Figure 5).

Remote sensing provides the capability of furnishing multivariate hydrologic data throughout the park which can be directly input into ecological models. Higer (1975) suggested that such models could be of significance in predicting success/failure of Wood Stork rookeries based on remotely sensed data (Figure 6). The prediction could be formulated through the application of satellite imagery

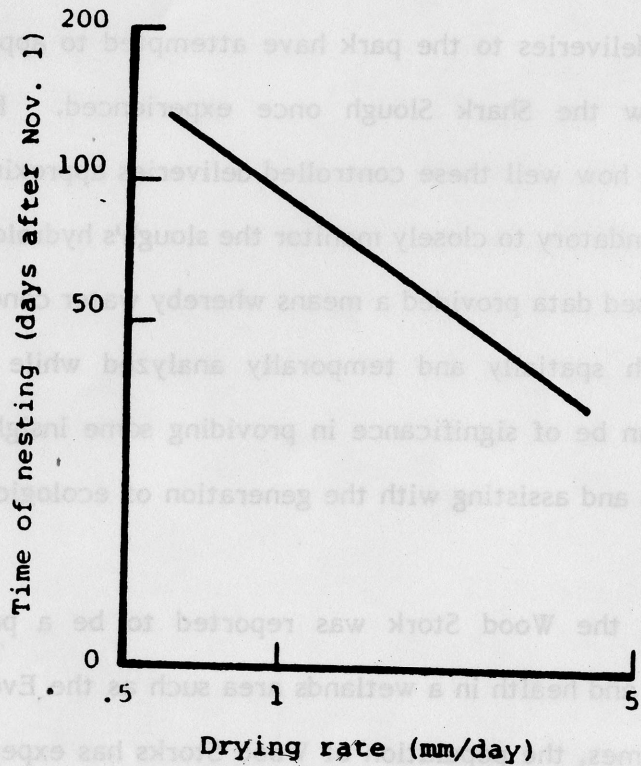

Figure 5. Relationship of timing of Wood Stork nesting in southern Everglades to hydrologic conditions (Kushlan 1975).

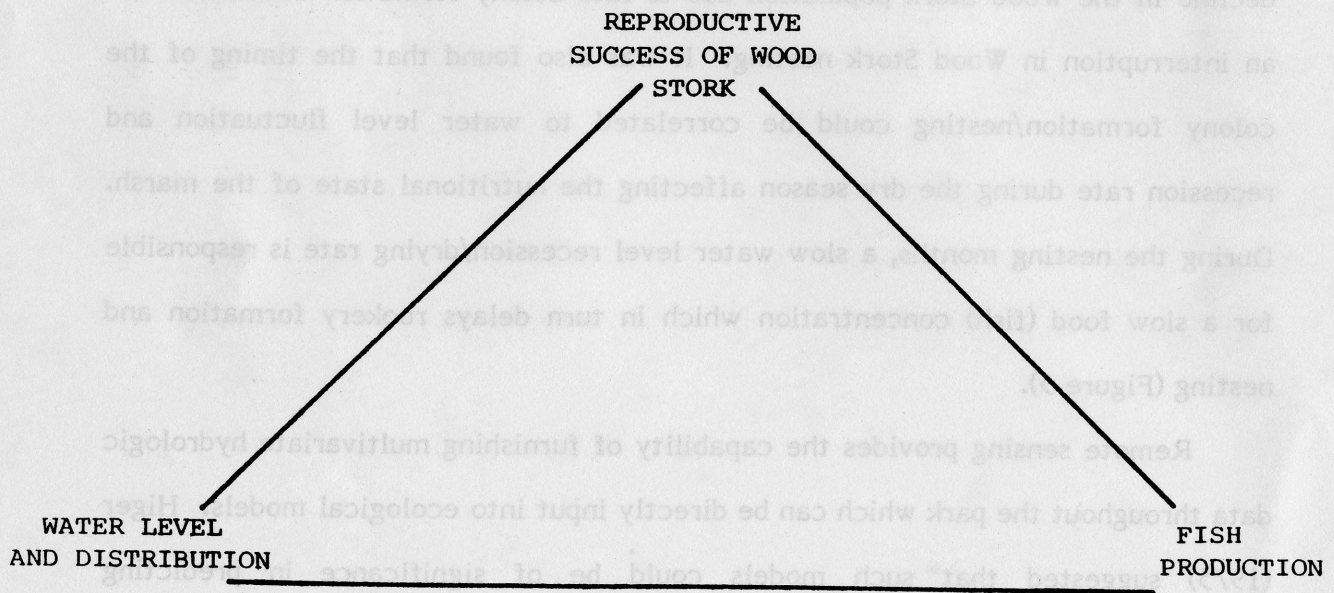

Figure 6. Wildlife ecological model of the Shark River Slough, Florida (Higer, 1975).

combined with point measurements. Hence, Higer concluded LANDSAT imagery could provide a good understanding of the quantity of water stored in the park; the spatial distribution of surface waters especially in regard to food availability and rookery success; and quantitative hydrologic data which would enable resource managers to make sound decisions regarding water delivery rates and amounts through the control structures.

Earth-Sun Relationships of Shark Slough

The rotation and revolution of the earth, combined with the inclination and polarity of the earth's axis are factors which influence the angle of incidence of incoming solar insolation. Associated with these occurrences are variations in the effectiveness of solar insolation due to changes in the transparency of the atmosphere. All of these factors directly influence the reflectance characteristics of the hydrobiological systems in the Shark River Slough and must be taken into consideration.

The earth-sun geometry for the Shark River Slough indicates the angle of incidence of incoming solar insolation which influences the reflectance values for the wetland marsh. Each year the sun's apparent path over the Shark Slough from December 21 (winter solstice) to June 21 (summer solstice) increases in the angle of incidence of the noon sun from 41° to a maximum of 88° above the horizon (Figure 7). The lowest angle of incidence occurs during the winter solstice (December 21) when the sun rises just south of east and sets just south of west. During this time period the greatest amount of energy is diffused over the ground surface thereby reducing the intensity of available light to be reflected from the slough. The maximum angle of incidence for this period of time is 41° above the horizon.

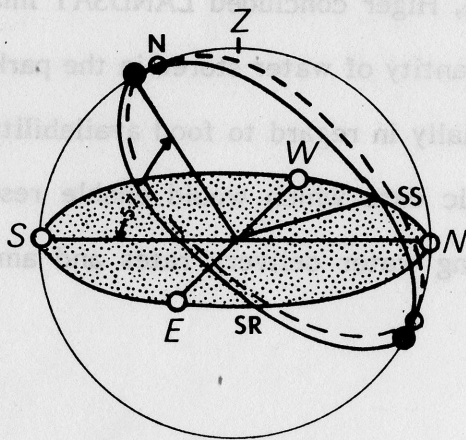

MARCH 3

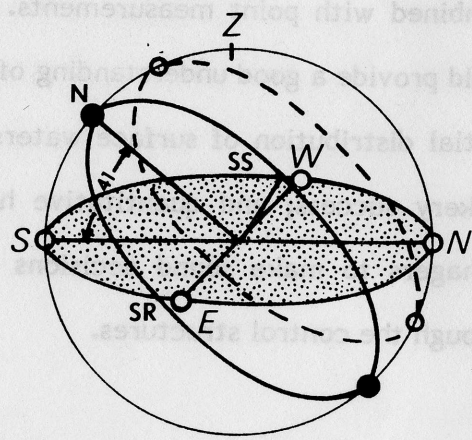

WINTER SOLSTICE

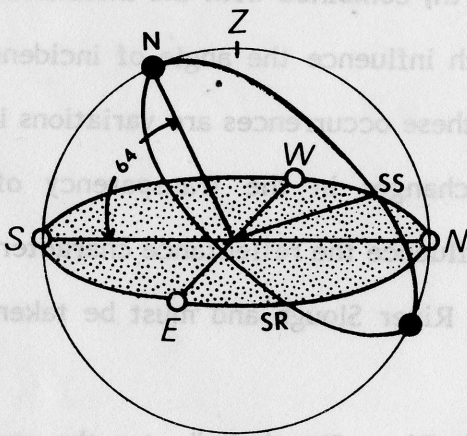

SPRING EQUINOX

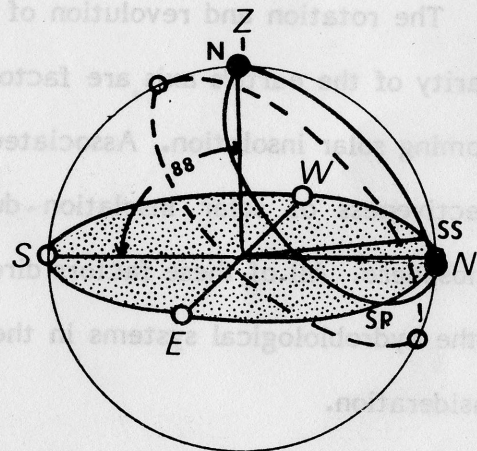

SUMMER SOLSTICE

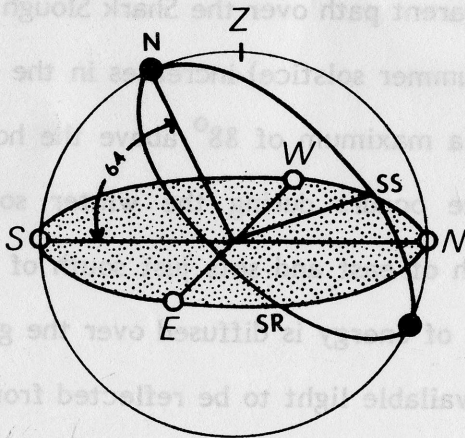

AUTUMNAL EQUINOX

N	NOON SUN
Z	ZENITH
SR	SUN RISE
SS	SUN SET
	HORIZON PLANE
	EQUINOX POSITION

Figure 7. Elevation of the noon sun above Shark River Slough (N25° 30' latitude)

Following the winter solstice, the path of the noon sun then begins to achieve greater angles above the horizon while the sun rises far north of east and sets far north of west. As the sun achieves greater angles above the horizon less light diffusion on the ground surface occurs due to changes in the transparency of the atmosphere and because the angle of incidence is close to perpendicular with the horizon (88°). Associated with these high angles for the noon sun are longer periods of daylight during the summer months. However, following the summer solstice (June 21) the angles begin to decline due to changes in the earth-sun relationships.

The critical factor for remote sensing applications in response to the changing earth-sun relationships is the water-light interface and the slough environment. Some of the problems with spectral reflectance measurements and remote sensing in the wetland marsh include (Anderson, 1972):

1. Seasonal changes in reflectance values: As the transparency of the atmosphere changes with earth-sun relationships, so does the reflectance value. This is particularly of prime importance in the Shark River Slough. Not only does the transparency of the atmosphere and the angle of incidence change for the incoming solar insolation but also the margins of the slough. Therefore reflectance values vary temporally and spatially between wet and dry seasons.
2. Shifts in plant orientation: The wind patterns experienced in the Shark River Slough could create problems in remote sensing applications due to vertical leafed plants exposing varying amounts of background water or soil.

Solar radiation responds in different ways to wetland areas depending upon the wavelength of light, angle of incidence, amount of suspended sediment/load of the water body and associated vegetative coverage. Under ideal conditions incoming solar radiation has four different multispectral responses (Scherz, 1971):

1. Ultra-violet: Penetrates the atmosphere, strikes the water surface and is immediately reflected back in space. However, the LANDSAT multispectral scanner does not record the ultra-violet wavelength of light and is therefore unaccounted for by the satellite sensors (Figure 8).
2. Blue-Green Energy: The best light penetration of a water body is achieved by the blue-green wavelengths of light (Figure 9). As the light encounters the surface of the water, penetration occurs and the light is returned to space. The green wavelengths are then intercepted and recorded on the MSS-4 band by the multispectral LANDSAT scanning device.
3. Infrared Wavelengths of Light: The infrared energy (near and far I.R.) achieves penetration of the water body but is absorbed by the first few inches of water (Figure 10). This is of significance to LANDSAT remote sensing applications in a wetlands environ because of the low reflectance values associated with the water in the MSS-6 and 7 multispectral bands.
4. Thermally Emitted Infrared (3 to 20 microns): The thermal I.R. is absorbed by the water except at the surface where it is emitted and returned to space (Figure 10). However, the LANDSAT multispectral scanner does not record the thermal I.R. wavelengths of light and therefore the information provided by thermal I.R. energy is not available.

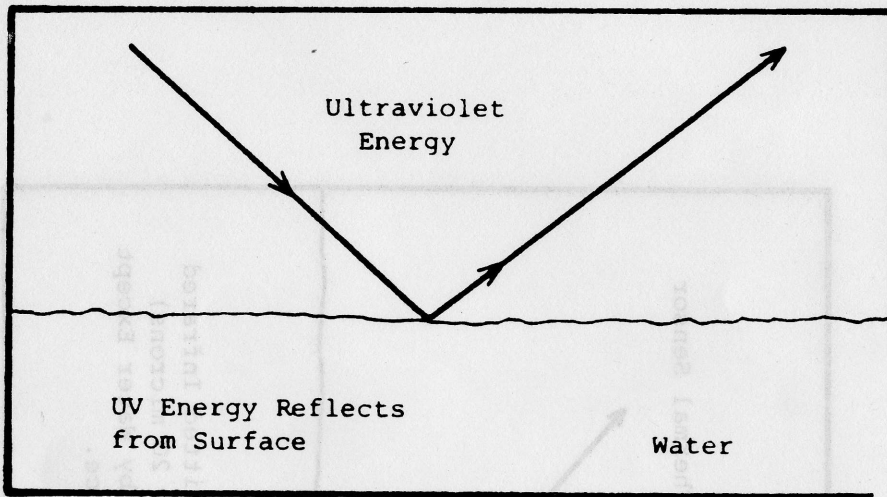

Figure 8 - INTERACTION OF ULTRAVIOLET ENERGY WITH WATER (Scherz, 1971)

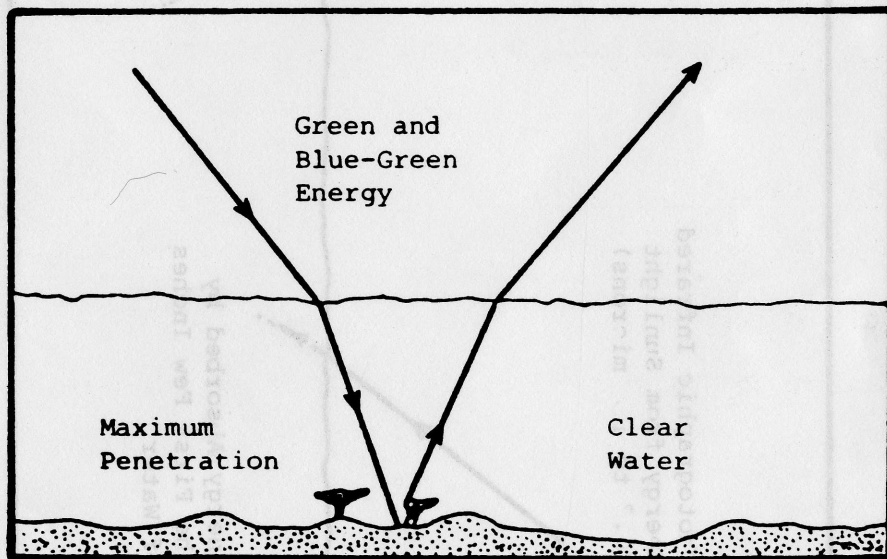

Figure 9 - INTERACTION OF GREEN AND BLUE-GREEN ENERGY WITH WATER (Scherz, 1971)

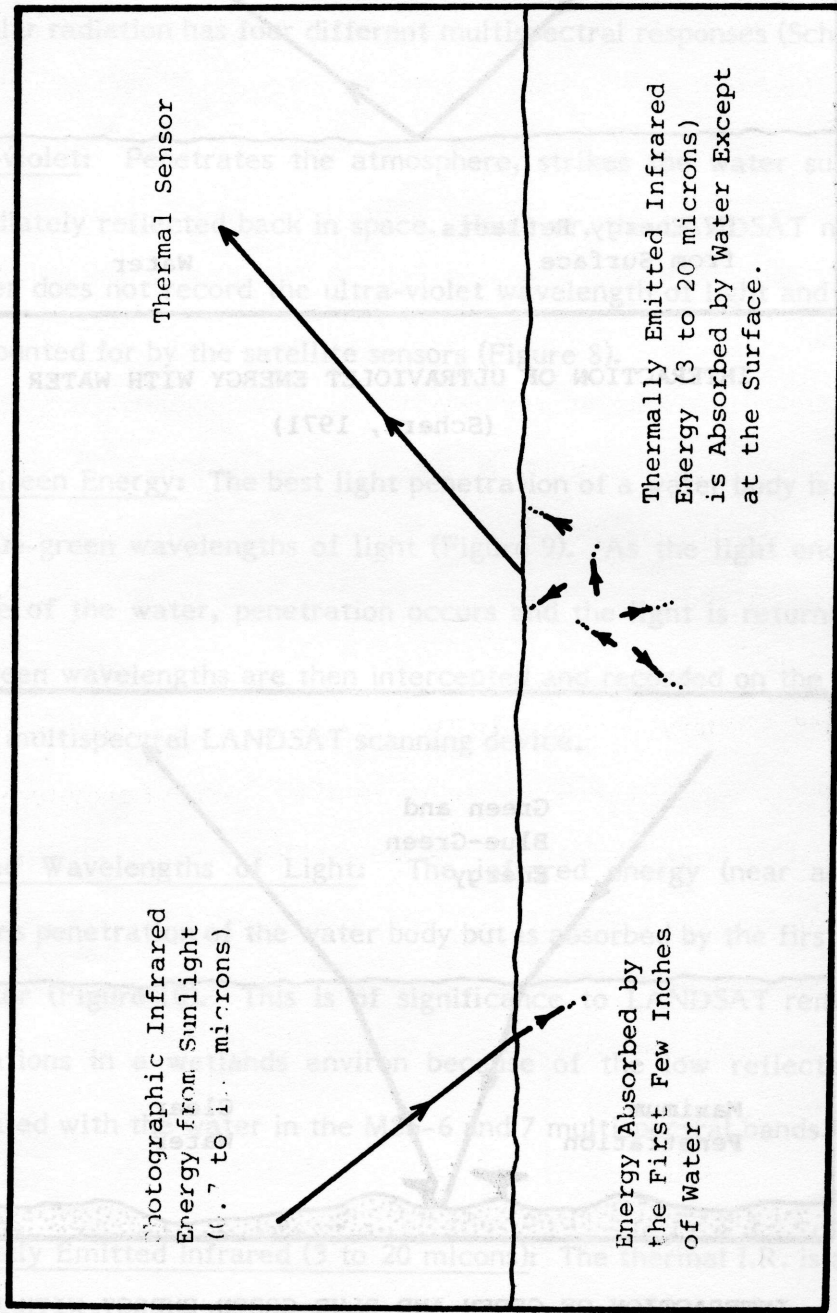

Figure 10. INTERACTION OF INFRARED ENERGY WITH WATER

(After Scherz, 1971)

These examples are indicative of the reaction of specific wavelengths of emitted energy as it interacts with a pure water body. However, as the suspended sediments increase in a given water body so does the amount of solar radiation reflectivity (Ritchie, 1976). It was shown that a change in the total concentration of dissolved sediments caused a significant change in the amount of radiation which is reflected off the water surface. A shift in radiance values between pure waters and waters with varying amounts of sediment loads was found. The highest reflectivity of a water body low in sediment was in the neighborhood of 550 nm. As sediments were introduced into a relatively pure water system, a shift occurred in reflectance values. A water body high in sediment load had its highest reflectivity in the 600 nm wavelengths of light (Figure 11).

These reflectance values are of significance to the Shark River Slough applications due to the spectral response of a particular wavelength of light in each specific hydrobiological zone. It is important to consider the relatively pure nature of the slough's waters combined with a floating algal mat (periphyton) and marshland vegetative forms when interpreting the LANDSAT signatures for a given hydrobiological feature. Taking this into consideration, combined with the angle of incidence of the incoming solar radiation, enables the best possible classification of the hydrologically active areas to be accomplished. The apparent reflectivity of Shark Slough's hydrobiological zones can be directly attributed to:

1. Earth-sun geometry
2. Reflections at the water/air contact
3. Reflections at the rock/air contact
4. Reflections from the slough bottom
5. Reflections from particulate matter suspended in the water

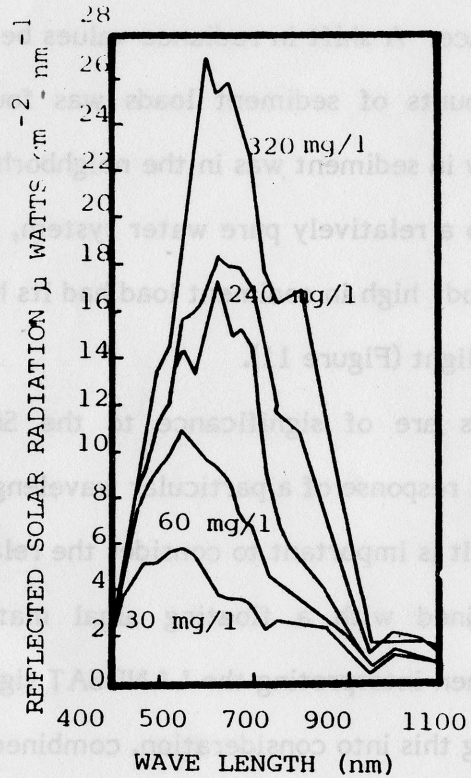

Figure 11. The relationship of reflected solar radiation with wavelength for different concentrations of suspended sediments in the surface water (Ritchie, 1976).

6. Reflections from marshland flora
7. Wind patterns which might expose background soil/water as well as causing ripples which would cause an increase in specular reflectivity.

METHODOLOGY

High flight aerial (U-2) photographs and LANDSAT multispectral imagery were utilized throughout this research. The procedure followed a systematic approach examining first the hydrobiological zones on the high flight aerial photography. The determinations made using the false color infrared photographs combined with detailed field studies were then directly applied to the LANDSAT scene. The multispectral reflectance values for each hydrobiological zone were then analyzed utilizing histograms and a statistical program. These data enabled an accurate and detailed automated extraction of hydrobiological data throughout the LANDSAT scene to produce hydrographic maps of the Shark Slough (Figure 12). These investigations will provide utility in developing a sounder hydrology program for Everglades National Park.

Study Area

The site selection for the intensive study area for this research was confined to an area within the Shark River Slough. The Shark Slough is the major conduit for surface water movement in Everglades National Park (Figure 13). In order for an area to qualify for site selection, the study area had to meet four basic criteria:

1. **Accessibility:** The study area had to be accessible to researchers by both airboat and helicopter with minimal impact to the environment.

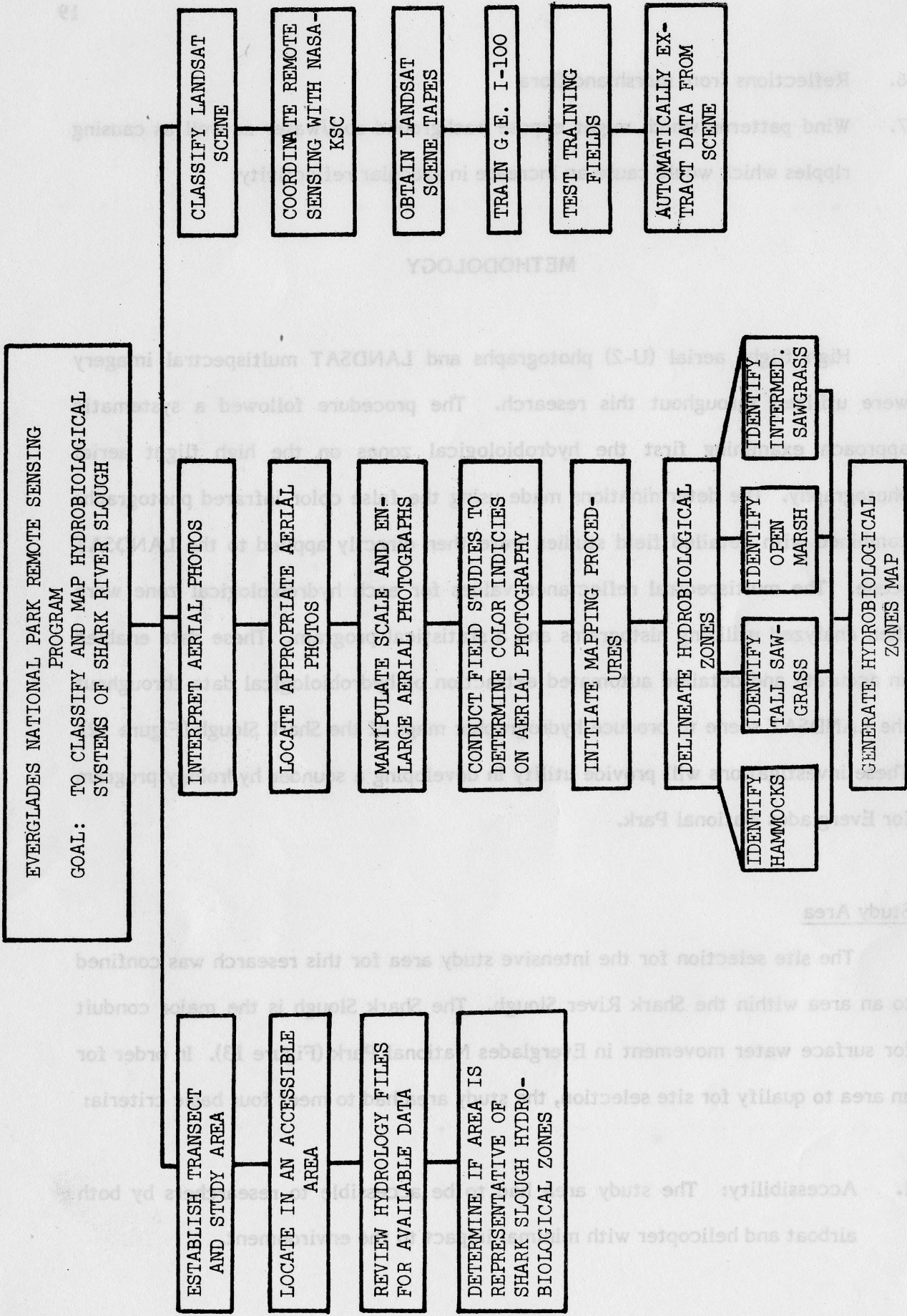

Figure 12. Step diagram of ENP-Shark Slough Remote Sensing Hydrobiological System Program

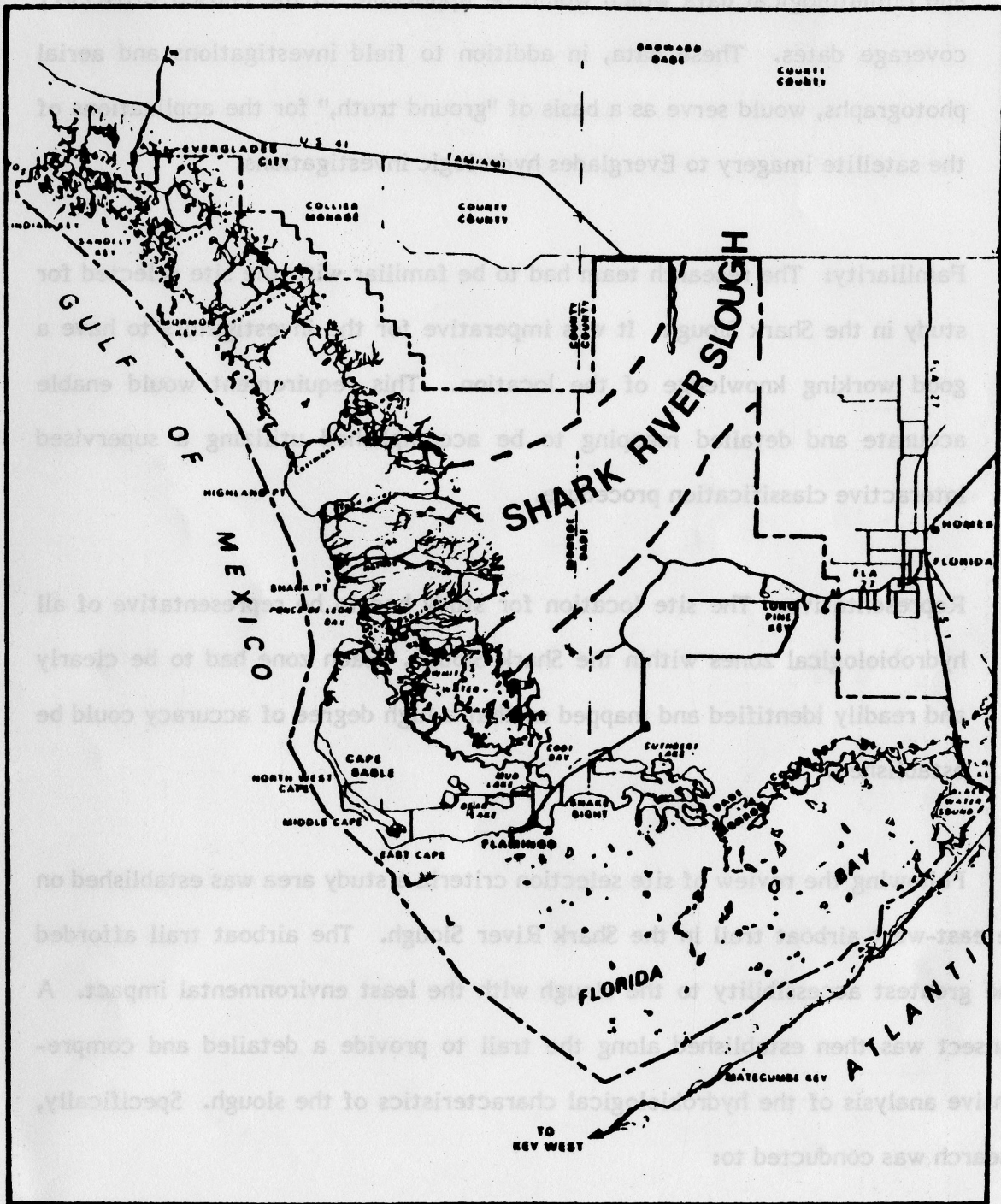

Figure 13. Shark River Slough, Everglades National Park

2. **Data Requirements:** The study area to be selected had to have hydrologic and climatological data which would be applicable to the chosen LANDSAT coverage dates. These data, in addition to field investigations and aerial photographs, would serve as a basis of "ground truth," for the applications of the satellite imagery to Everglades hydrologic investigations.
3. **Familiarity:** The research team had to be familiar with the site selected for study in the Shark Slough. It was imperative for the investigators to have a good working knowledge of the location. This requirement would enable accurate and detailed mapping to be accomplished utilizing a supervised interactive classification procedure.
4. **Representative:** The site location for study had to be representative of all hydrobiological zones within the Shark Slough. Each zone had to be clearly and readily identified and mapped so that a high degree of accuracy could be established.

Following the review of site selection criteria a study area was established on the east-west airboat trail in the Shark River Slough. The airboat trail afforded the greatest accessibility to the slough with the least environmental impact. A transect was then established along the trail to provide a detailed and comprehensive analysis of the hydrobiological characteristics of the slough. Specifically, research was conducted to:

1. Monitor the hydrological conditions in the slough throughout the year to document the cyclic nature and extent of the expanding/contracting slough margins.

2. Determine the flow characteristics of the surface waters in Shark Slough's hydrobiological zones.
3. Document flow velocities (sheet flow) associated with each hydrobiological zone.
4. Analyze vegetative characteristics which would influence reflectance values for the slough's hydrobiological zones.

A portion of the transect was utilized as an intensive study area for remote sensing applications. The four and a half mile transect length encompassed all hydrobiological zones from hydrologic stations E-1 to P-33 (Figure 14). In addition, the transect width was approximately one mile (half mile sections on either side of the airboat trail). The diverse but compact intensive study area enabled the most detailed and accurate analysis of the hydrobiological zones to be generated.

Hydrobiological zones are those areas which directly influence the rate (velocity) of overland sheet flow through the Florida Everglades. From field studies completed in Everglades National Park it was determined that four major hydrobiological zones are present in the Shark River Slough. Each zone has a distinct and different flow rate. The hydrobiological zone which experiences the fastest flow velocities is the open marsh (open ponded) area. The open marsh is largely composed of open water areas which are interrupted by Eleocharis, maidencane, and sawgrass. The intermediate sawgrass area experiences a slightly slower flow rate. The intermediate sawgrass group is composed of a fairly dense

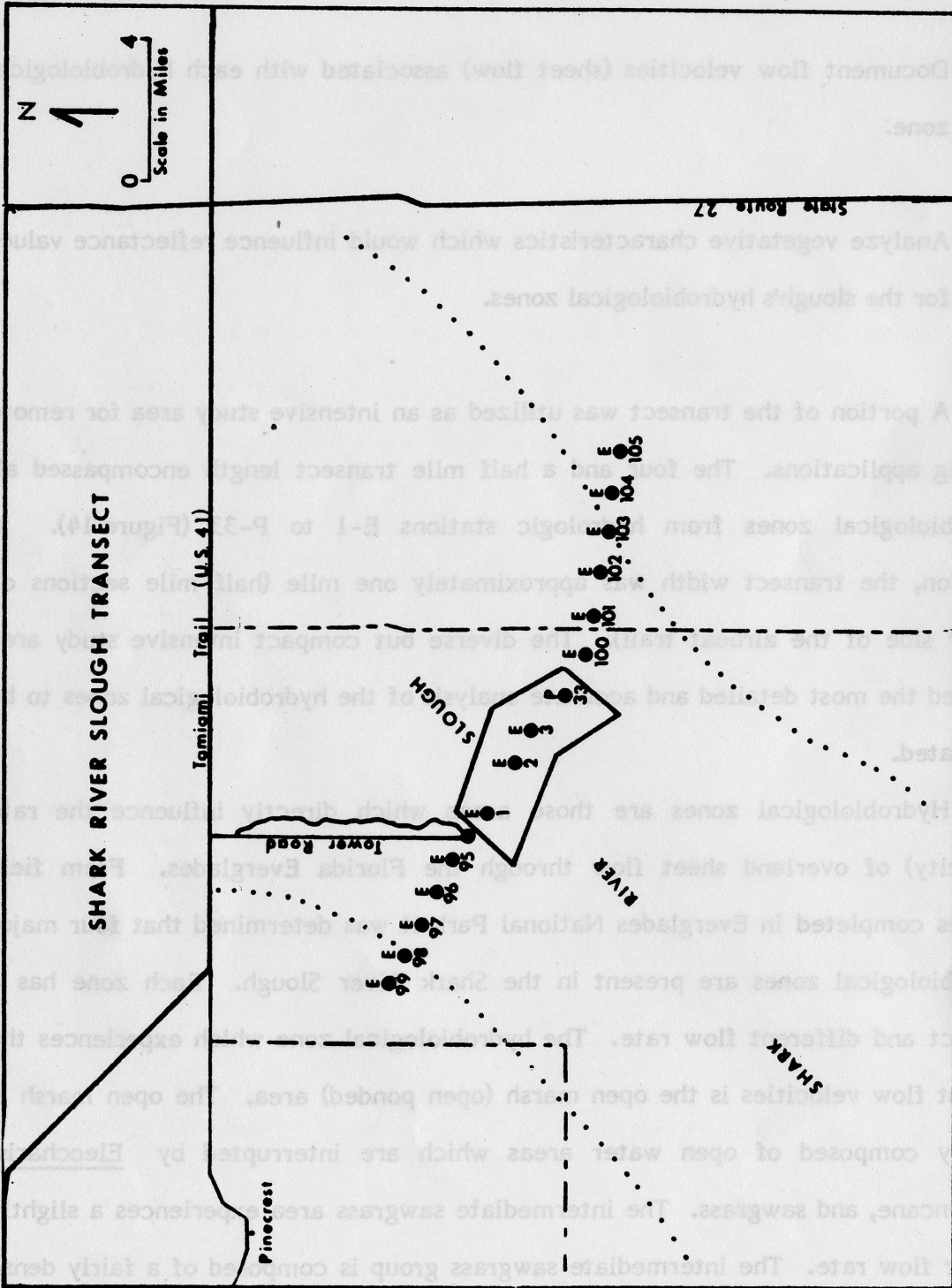

Figure 14. Transect Location, Shark River Slough

sawgrass community which does not exceed 3.5 feet (1 m) in height. Water velocities again slow even further when the overland sheet flow encounters the tall sawgrass hydrobiological zone. The tall sawgrass community exceeds 3.5 feet (1 m) in height and it grows in dense vegetative stands. The slowest velocities are experienced in the hammocks and bayheads. Many of the hammocks experience no (zero) flow because they represent areas which are higher in ground elevation than the surrounding surface waters.

Rhodamine tracer dye tests in the Florida Everglades by National Park Service hydrology personnel have verified these general flow characteristics in each hydrobiological system. Tracer dyes in the open marsh peaked at a rate 1.6 times faster than the intermediate sawgrass and 2.0 times faster than tall sawgrass (Figure 15). All hydrobiological zones in the wetlands marsh area of the Everglades were contained within the intensive study area. DeMauro, 1978, mapped each zone along the transect in conjunction with a Shark River Slough soil study. A detailed transect profile was completed to indicate the extent to which each of these zones intercept the transect (Figure 16).

Aerial Photo Analysis

Aerial photography is of paramount importance in the development of a remote sensing applications program. The aerial photo coverage for South Florida and Everglades National Park is quite good. Since 1940 aerial photographs have been generated on a frequent basis helping to document the dynamic conditions of the Florida Everglades.

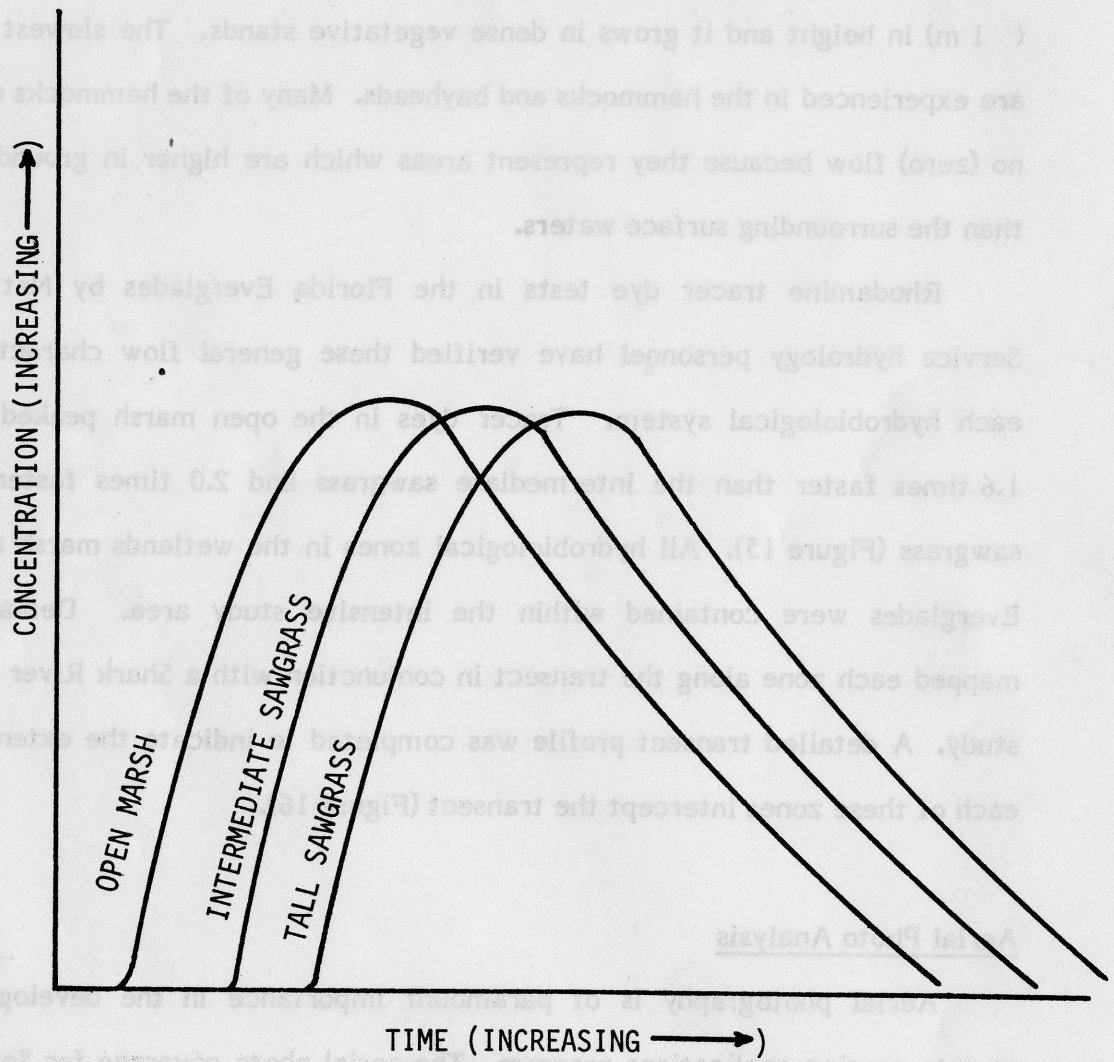
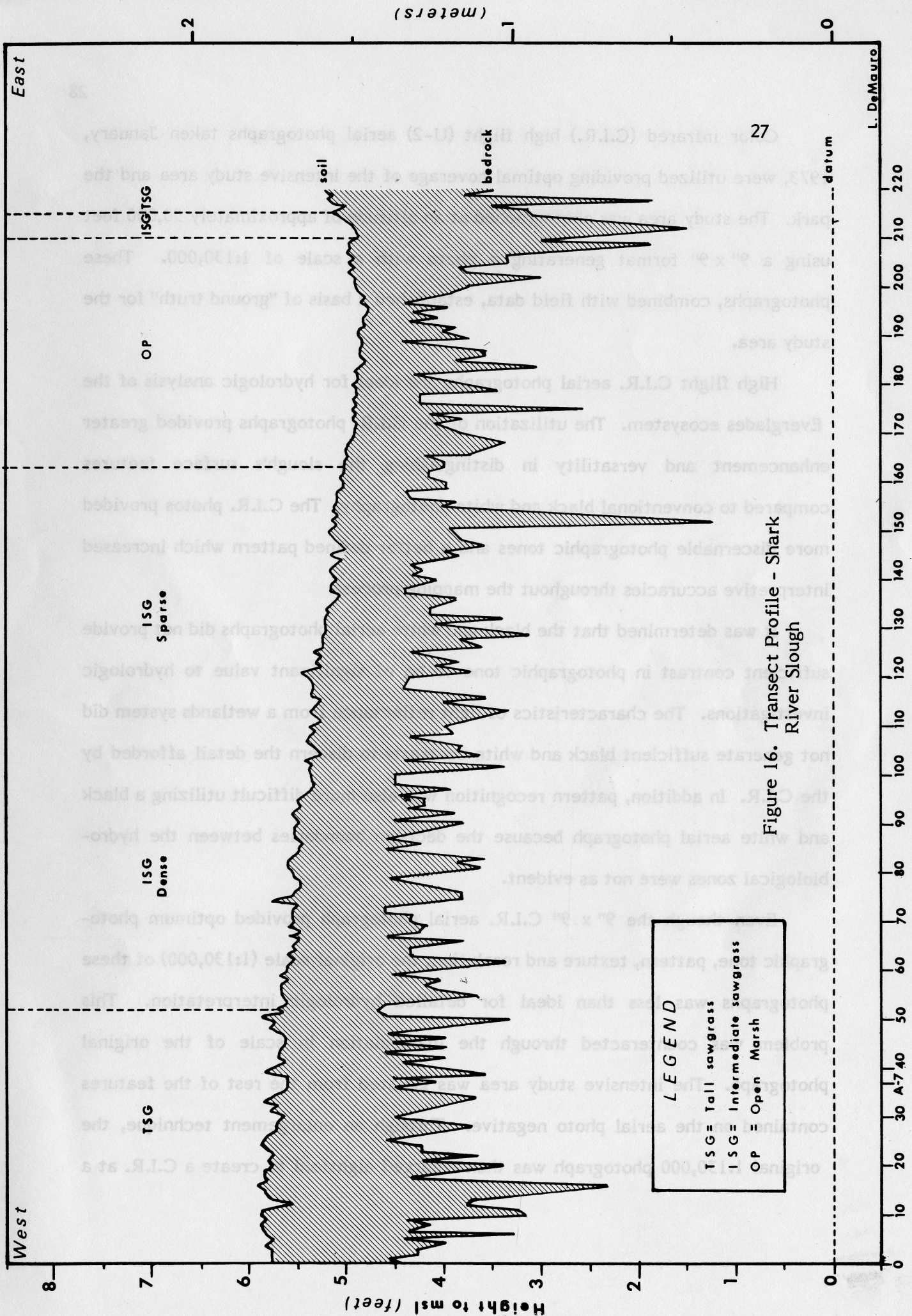

Figure 15. Rhodamine Tracer Dye (Concentration vs. Time) Curves

SHARK RIVER SLOUGH PROFILE—Transect 1-D (220 feet)
 Stations 0 to 220 (1-foot intervals)



LEGEND

- TSG = Tall sawgrass
- ISG = Intermediate sawgrass
- OP = Open Marsh

Figure 16. Transect Profile - Shark River Slough

Color infrared (C.I.R.) high flight (U-2) aerial photographs taken January, 1973, were utilized providing optimal coverage of the intensive study area and the park. The study area was photographed at an altitude of approximately 50,000 feet using a 9" x 9" format generating a photo with a scale of 1:130,000. These photographs, combined with field data, established a basis of "ground truth" for the study area.

High flight C.I.R. aerial photographs are ideal for hydrologic analysis of the Everglades ecosystem. The utilization of the C.I.R. photographs provided greater enhancement and versatility in distinguishing the slough's surface features compared to conventional black and white photography. The C.I.R. photos provided more discernable photographic tones and a better defined pattern which increased interpretive accuracies throughout the mapping process.

It was determined that the black and white aerial photographs did not provide sufficient contrast in photographic tone to be of significant value to hydrologic investigations. The characteristics of light reflectance from a wetlands system did not generate sufficient black and white contrasts to discern the detail afforded by the C.I.R. In addition, pattern recognition was also more difficult utilizing a black and white aerial photograph because the decision boundaries between the hydrobiological zones were not as evident.

Even though the 9" x 9" C.I.R. aerial photograph provided optimum photographic tone, pattern, texture and resolution, the original scale (1:130,000) of these photographs was less than ideal for detailed hydrologic interpretation. This problem was counteracted through the manipulation in scale of the original photograph. The intensive study area was isolated from the rest of the features contained on the aerial photo negative. Through an enlargement technique, the original 1:130,000 photograph was then enlarged eightfold to create a C.I.R. at a

scale of 1:16,600 (3.90 inches to the mile). This enlargement provided for the most detailed and accurate mapping of the hydrobiological zones to be accomplished while maintaining high resolution and providing good contrasts for each hydrologically active area.

Following the employment of the enlargement technique and the generation of a suitable aerial photo C.I.R., field studies were then initiated. The enlarged photograph was taken directly into the field for analysis/interpretation of critical areas. Both helicopters and airboats were utilized to transport field personnel throughout the study area and the Shark River Slough. The airboat was extremely useful in providing mobility to researchers assessing hue changes within each hydrobiological zone observed on the photograph and relating it to the exact position in the field. In addition, the helicopters were utilized to evaluate each hydrobiological zone from the air, evaluate its photographic tone and pattern, and to generate aerial oblique photographs in a 35 mm slide format. The oblique photographs were of value in accessing the accuracy of the subsequent hydrobiological map of the study area.

Once the field studies in the intensive study area had been completed the detailed mapping of the hydrobiological zones commenced. The mapping was accomplished utilizing both the enlarged (scale 1:16,600) C.I.R. aerial photograph as well as the original (scale 1:130,000) 9" x 9" C.I.R. stereo pairs for the study area. A Topcon mirror stereoscope with a field 30 mm in diameter at a six power magnification was used in conjunction with the stereo coverage. This procedure enhanced the interpretive process clarifying areas in question on the enlarged C.I.R. aerial photo while improving the mapping accuracies.

The most readily identifiable hydrobiological zone contained within the study area was the hammocks and bay heads. The hammocks/bay heads found in the Shark River slough are primarily composed of gumbo limbo, oaks, Lysiloma, cocoplum, red bay and willow tree species. These hardwood trees, supporting a canopy of broad leaves, produced an intense red hue which distinguished them from all other hydrobiological zones. The hammocks/bay heads were delineated at their boundary of maximum extent and were then mapped accordingly.

Tall sawgrass was also easily identified even though its interpretation was more complex. Normally, most of the tall sawgrass was either associated with the hammocks, forming the tail of a hammock, or existed as isolated strands in the slough. The photographic texture of tall sawgrass was very coarse and its hue was primarily a dark, dull red/orange. At times, a confusing but yet recognizable cream color could be seen in small areas within certain tall sawgrass zones. However, due to the prominent shape, pattern and location of the tall sawgrass, this minor confusion does not interfere with the interpretive process (after it has been recognized and identified). Taking these observations into consideration the tall sawgrass was then delineated and mapped.

The intermediate sawgrass group presented some interpretive problems. The color (dark brown with some red) was difficult to discern as it blended in with the darker colors on the C.I.R. aerial photograph. Contributing to the confusion was a periphyton (algal mat) cover which had to be accounted for within the intermediate sawgrass zone. The original field studies in the slough assisted in solving the interpretive difficulties encountered with the intermediate sawgrass group and once it was accounted for the intermediate sawgrass zones were delineated.

The fourth hydrobiological zone to be mapped was the open marsh systems in the study area. The open water areas were not as easy to recognize as one would be left to believe considering light reflectance characteristics in the infrared

spectrum of light. The open marsh contained periphyton within these areas. This resulted in a highly reflective zone contained within the open marsh. The overall result was to produce a dull pink to a bright whitish-pink tone. At first this tone would appear to suggest an intermediate sawgrass area, however, upon examination, this hue was found to represent those areas of open marsh with a considerable amount of periphyton. In addition, areas devoid of periphyton registered from an aqua-blue to the typical black spectral response for water in the infrared. Following this analysis, the open marsh areas were delineated and mapped according.

The hydrobiological map that was generated clearly and accurately delineated these four critically active hydrological zones in the intensive study area. As would be expected, the Shark River Slough is comprised mainly of two hydrobiological zones; the open marsh and the intermediate sawgrass. The hammocks and the bay heads represent a very small fraction of the slough which occasionally interrupts the vast expanse of sawgrass. Finally, the tall sawgrass occurs as major strands in the slough or in conjunction with the hammocks and the bay heads.

Computer Applications

Subsequent to the field and C.I.R. aerial photo analysis was the automated extraction of the hydrobiological zones from the LANDSAT computer-compatible tape (CCT). The supervised interactive processing of the multispectral digital LANDSAT data was accomplished utilizing a G. E. Image 100 Interactive Image Analysis System (G. E. I-100). Both the G. E. I-100 and the LANDSAT CCT were furnished by the National Aeronautics and Space Administration-Kennedy Space Center (NASA-KSC) as a cooperative effort with the National Park Service.

Acquisition of ENP LANDSAT Data

Since the onset of the LANDSAT program in 1972, Everglades National Park and South Florida have had continuous repetitive satellite coverage during both the wet and dry seasons. However, due to the presence of clouds during the satellite overpasses (especially during the wet season) many LANDSAT scenes of the park contain greater than 20 percent cloud cover. In most cases an image containing greater than 20 percent cloud obstruction is rendered of little value to hydrologic applications in the Florida Everglades.

An analysis was completed to determine those LANDSAT overflights for Everglades National Park which could be of value to a remote sensing program. A computer search was initiated through the EROS Data Center, U. S. Geological Survey in Sioux Falls, South Dakota. The maximum extent of cloud cover was restricted to the 20 percent threshold value. In addition, the quality of each multispectral band was not to be less than a level of 5 (EROS Data Center rates the quality of the image from 0 - 9, with 9 being the best possible quality available). The analysis revealed that a total of eighteen LANDSAT overflights meet the criteria since the launching of the first satellite (LANDSAT) in 1972 (Table 2).

The date selected for computer processing of the hydrobiological zones was the March 3, 1975, overflight. The LANDSAT-2 satellite generated the data contained on the CCT and all multispectral bands were of good quality. Each MSS-band had a quality of 8 and the tape was on file at NASA-KSC.

The March 3, 1975 acquisition date was ideal for hydrobiological applications of the satellite data in the Shark River Slough. Hydrologic field investigations had been conducted in the slough just after the satellite overflight and the park's

Table 2.

ACCEPTABLE ERTS/LANDSAT COVERAGE DATES FOR ENP

(Quality 5; Cloud 20%)

<u>Date</u>	<u>Satellite</u>	<u>MSS</u>				<u>Cloud</u>	<u>CCT</u>	<u>CCP</u>
		<u>4</u>	<u>5</u>	<u>6</u>	<u>7</u>			
5/16/78		5 or better				20		
4/28/78	LANDSAT-2	-	8	-	-	20		
3/23/78	LANDSAT-2	5	8	8	8	10		
3/14/78	LANDSAT-3	8	8	8	8	20		
2/15/78	LANDSAT-2	8	8	8	5	20		
1/28/78	LANDSAT-2	8	8	8	8	20		
1/10/78	LANDSAT-2	8	M	5	8	10		
12/29/77	ERTS-1	M	5	5	5	10		
12/5/77	ERTS-1	5	5	5	5	20		
11/17/77	ERTS-1	M	M	8	8	10		
9/30/77	ERTS-1	M	8	2	8	10	P	P
4/2/76	LANDSAT-2	8	8	8	8	10	Y	P
12/7/75	ERTS-1	5	8	8	8	10	P	P
3/3/75	LANDSAT-2	8	8	8	8	20	Y	Y
12/30/74	ERTS-1	8	8	8	8	10	Y	P
10/19/74	ERTS-1	8	8	5	8	10	Y	Y
10/24/73	ERTS-1	2	8	8	2	10	Y	Y
3/22/73	ERTS-1	5	8	2	8	0	P	

hydrology files documented all hydrologic conditions in and around the park for that particular date.

During the overflight on March 3, 1975, the park and South Florida experienced hydrologic conditions typical of the dry season. No rain had fallen for at least 3 days at Flamingo and Royal Palm Ranger Stations while just a trace was recorded at Tamiami and Everglades City Ranger Stations (Table 3).

Water levels throughout the park were very low and there were no surface waters present near the Rookery Branch area in the Shark Slough. The surface water levels in Conservation Area 3A were also below normal.

The G. E. I-100 facilitates the automated extraction of LANDSAT data from the CCT based on the theorem that all objects possess a unique characteristic. These characteristics translate into spectral signatures which are utilized by the G. E. I-100 to identify specific features. The decision to include a particular signature into a specified class is based upon a simultaneous multi-spectral or multi-frequency analysis by the computer. Those classes which statistically possess unique spectral signatures are then assigned a theme and the classification of an entire LANDSAT scene, or part of, is accomplished (Figure 17).

The digitized LANDSAT CCT contains the specific reflectance values recorded by the satellite sensors. As the LANDSAT satellite passes over any particular area the multispectral scanner (MSS) system records the emergent radiation from the surface of the earth. The scanner is a line scan device which records the four distinct wavelengths of light.

The orbital path of the satellite enables the data to be acquired on a line-by-line (east/west) format which generates a continuous image. A scene is completed when a total of 2480 scan lines have been recorded within a given framework. Each scan line contains 3240 picture elements (pixels) and there are over 7.5 million pieces of data for each band. The total area contained within a

Table 3: March 3, 1975 Hydrologic Data Corresponding to LANDSAT Overflight.

RAINFALL					
<u>Date</u>	<u>Tamiami Ranger Sta.</u>	<u>Everglades City</u>	<u>Flamingo Ranger Sta.</u>	<u>Royal Palm</u>	
March 1	0	0	0	0	
March 2	0	0	0	0	
March 3	0.03	0.02	0	0	

WATER LEVELS - S-12					
	<u>A</u>	<u>B</u>	<u>C</u>	<u>D</u>	<u>E</u>
Upstream	7.93	7.85	7.86	7.86	6.99
Downstream	7.90	7.85	7.86	6.56	6.55

CONSERVATION AREAS		
	<u>Level</u>	<u>Normal Level</u>
Lake Okeechobee	13.80	14.04
Conservation Area 1	15.80	15.46
Conservation Area 2	12.46	12.66
Conservation Area 3	7.94	9.00

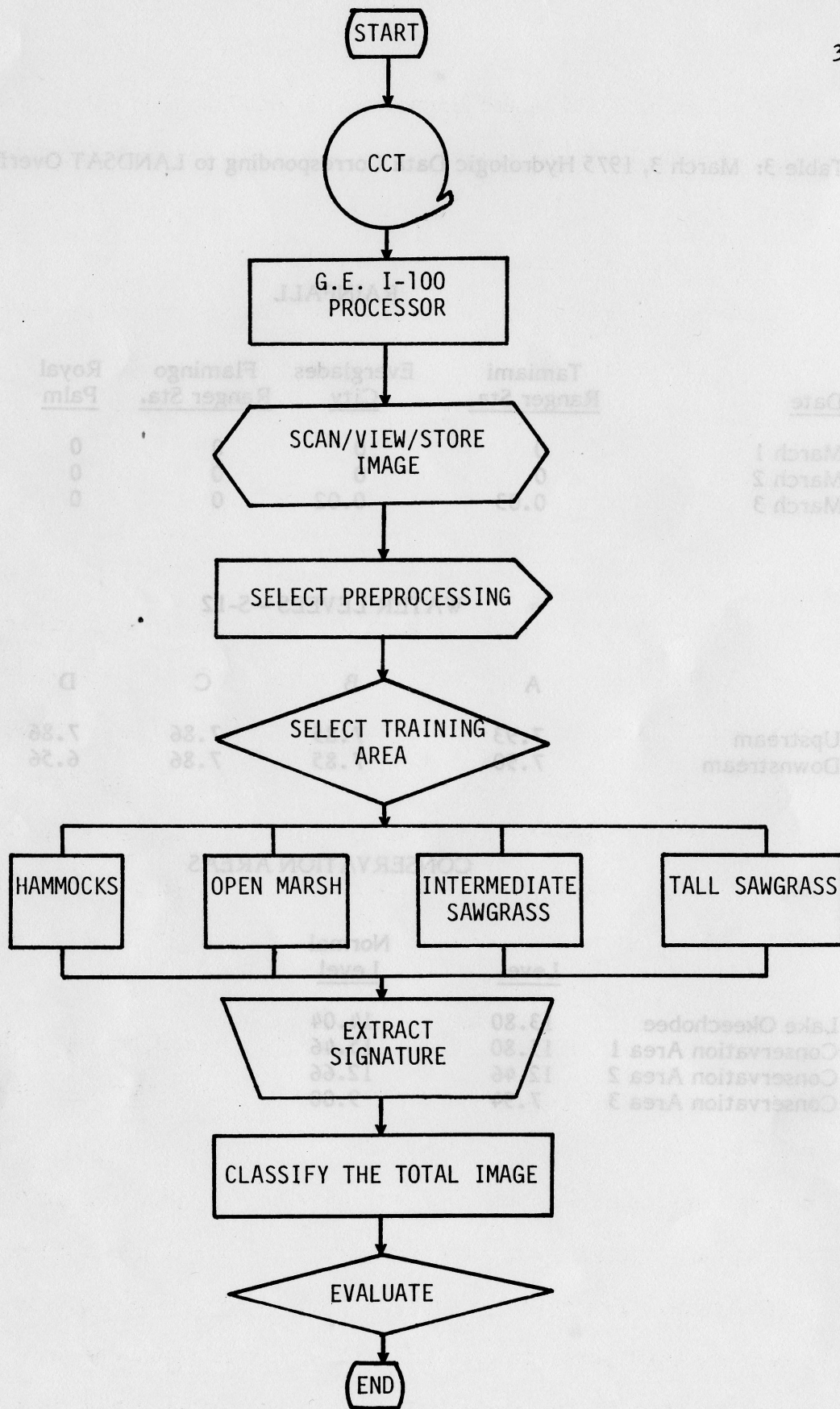

Figure 17. Flow diagram for classification of LANDSAT CCT utilizing GE-I-100 Processor

LANDSAT scene is 185 square kilometers (100 x 100 nautical miles). The remotely sensed data for each pixel contains four sets of binary numbers which contain a mean specific intensity producing a gray scale range which can be statistically analyzed by a digital analyzer such as the G. E. I-100.

The capabilities of the G. E. I-100 enable an area of 512 by 512 pixels to be classified at a given time. This translates into over one million bites of data which are simultaneously classified by the digital analyzer.

Training

Once the LANDSAT CCT is acquired and input into the digital processor the image is displayed on a color cathode ray tube (CRT). The CRT is a high resolution, 525 line, TV monitor which allowed the viewing of either the LANDSAT imagery or the training/classification results. The CRT is capable of displaying a maximum of 512 elements by 488 lines per scene. Classification can be generated on all 512 lines, however, only 488 lines can be displayed on the CRT (due to the CRT's vertical retrace requirement). The remaining 24 lines are stored in the image memory unit of the processor.

For training purposes the CRT split-screen formatting was utilized exclusively. The intensive study area was located on the LANDSAT scene displayed on the CRT. The study area was then delineated utilizing a cursor. A scale factor was specified and the study area was digitally magnified and overwritten on a portion (non-essential to classification) of the LANDSAT image using the window display mode. Two display windows were required to display the enlarged study area in the Shark Slough on the CRT. This procedure enabled accurate and precise definition of each hydrobiological zone in the slough while maintaining high resolution.

The primary mode of training utilizing the G. E. I-100 at NASA-KSC was the single cell signature acquisition mode. After a site had been selected for training purposes the processor then obtained the gray level distribution contained within that site in all four multispectral channels. Histograms (one-dimensional) for each training site were then generated to determine the upper and lower limits for the spectral distribution in that set. These boundaries defined the N-dimensional hyperparallelepiped in spectral space for the training area. That is, a region (training set) in feature space is described, in four dimensions, by the upper and lower gray level distribution limits. The radiance (gray level) values defining these limits are determined and the statistics for a given training set are generated. Included in the statistical package are the means, peaks and variances.

Each of the four hydrobiological zones in the Shark River Slough were trained utilizing the single-cell signature acquisition mode and a supervised interactive approach. The iterative training, combined with a schematic approach, based on complexity, enabled all zones to be accounted for and mapped according by the image processor and the remote sensing/data processing analysts. The easiest and most prominent hydrobiological zone to train was the hammocks. This training was followed by the tall sawgrass, intermediate sawgrass and the training was completed after the digital processor could identify the open marsh's spectral properties.

Subsequent to all training procedures was the classification of the hydrobiological zones contained in the Shark River Slough. The 512 x 488 pixel scene displayed on the CRT was ideal for ENP hydrologic application and classification. Much of the park, including all of the Shark River Slough was displayed on the CRT monitor.

Classification is primarily the assignment of a pixel to a theme (class), or in this case a hydrobiological zone, based on the spectral properties of that pixel. In order for a classification to be accurate, it is paramount that the training be as accurate as possible and all spectral properties contained within the area of concern must have been accounted for accordingly. The G. E. I-100, during the classification process, scans the entire 512 x 512 four channel input imagery, pixel-by-pixel, and assigns each pixel to a class based upon its spectral properties and its correlation to the radiance values for the training sets. The entire 270,000 acres in the Shark Slough were classified in less than 3 seconds per hydrobiological zone.

Accuracy Assessment

Accuracy assessment is necessary in order to determine how successfully a ground feature can be identified and mapped by an automatic processing system. The success/failure of a training site or classification of a LANDSAT scene depends on whether the pixel was placed into the correct class. The percentage accuracy of a classification then directly reflects on the ability of a computer to identify each pixel within a scene, or part of, and place it in the correct class based on the input statistics generated during the training procedures.

Training and classification accuracies were assessed throughout the processing mode. The supervised interactive approach enabled each training site to be evaluated prior to classification. All ground truth, including the hydrobiological systems map, were utilized during the training procedure. Only those areas within the intensive study area which were most representative of the hydrobiological systems were chosen as training sites. The familiarity of the researchers with the selected areas, combined with the ground truth, enabled all pixels representative of each hydrologically active zone to be included in the training sites. This procedure resulted in fewer pixel misclassifications in the final product generation and less thresholding of the pixels throughout the classification.

The accuracy assessment was also conducted on the classification after product generation. A random sample of pixel classification accuracies was conducted through the employment of a grid network. The accuracy test was performed at the intersection of the x and y axis on the grid. Each test site was chosen by the random number table method and the pixel was either classified correctly or incorrectly. In addition each classified pixel per hydrobiological zone was tested against the ground truth of the intensive study area to determine classification accuracies. Through the application of these techniques, the percentage accuracy for each hydrobiological zone was determined and analysis made regarding the ability of the classifier to recognize the hydrobiological zones in a slough wetland area.

IV. SIGNIFICANT RESULTS

It was determined that remote sensing is a viable tool for hydrologic applications in the Florida Everglades. The satellite imagery/CCT can provide a basis for accurate and detailed automated extraction of scientific data. This research found that the hydrobiological zones in the slough's ecosystem could be accurately delineated. The spectral response of each hydrobiological zone can be plotted so that the LANDSAT signatures of the Shark River Slough could be identified. Histograms and statistics were generated during the training/classification procedure so that greater insight into the spectral response of each zone could be analyzed. Through spectral plotting relationships the multispectral relationships between the emittent energy from the slough was determined so that the best possible wavelengths of light to utilize would be known in order to enhance the classification results. Finally, this research determined, for the first time, the total area involved with each hydrobiological zone contained

within the Shark River Slough and the associated conceptual flow vectors were generated. This is of paramount importance to future ENP hydrology studies and flow models which will be developed.

Shark Slough's LANDSAT Signatures

Plots of the LANDSAT spectral reflectance for each of the hydrobiological systems were developed (Figure 18). These plots indicate the relationships between the reflectance of each hydrobiological zone and its relationship to each LANDSAT multispectral band. The resultant signature plot was generated utilizing the mean reflectance values for each hydrobiological zone.

The lowest emergent energy from the Shark River Slough, as would be expected, was the open marsh system. The open marsh is composed mainly of open ponded areas which contain Eleocharis, sawgrass, maidencane and an algal floating mat (periphyton). The lowest reflectance within the open marsh occurs in the 0.6 to 0.7 μm (MSS-Band 5) wavelengths of light. The open marsh displays similar mean reflectance signatures in both MSS-Band 4 (0.5 to 0.6 μm) and MSS-Band 7 (0.8 to 1.1 μm).

Contrary to the open marsh hydrobiological zone, the hammock group displayed the highest mean reflectivity of all four groups. The dense, thick-leaved trees within the hammocks produced the most distinct signature and the easiest to classify in MSS-Band 7 (0.8 to 1.1 μm).

The sawgrass zones (tall and intermediate) were the two systems which were the most difficult to spectrally separate. The composition of each sawgrass group and the density of vegetative growth generated a higher spectral response in the far infrared (MSS-Band 7). However, utilizing only Band 6 (0.7 to 0.8 μm) the distinct separation of these two hydrobiological zones would be impossible. The signature responses are similar in the green and red wavelengths of light with the

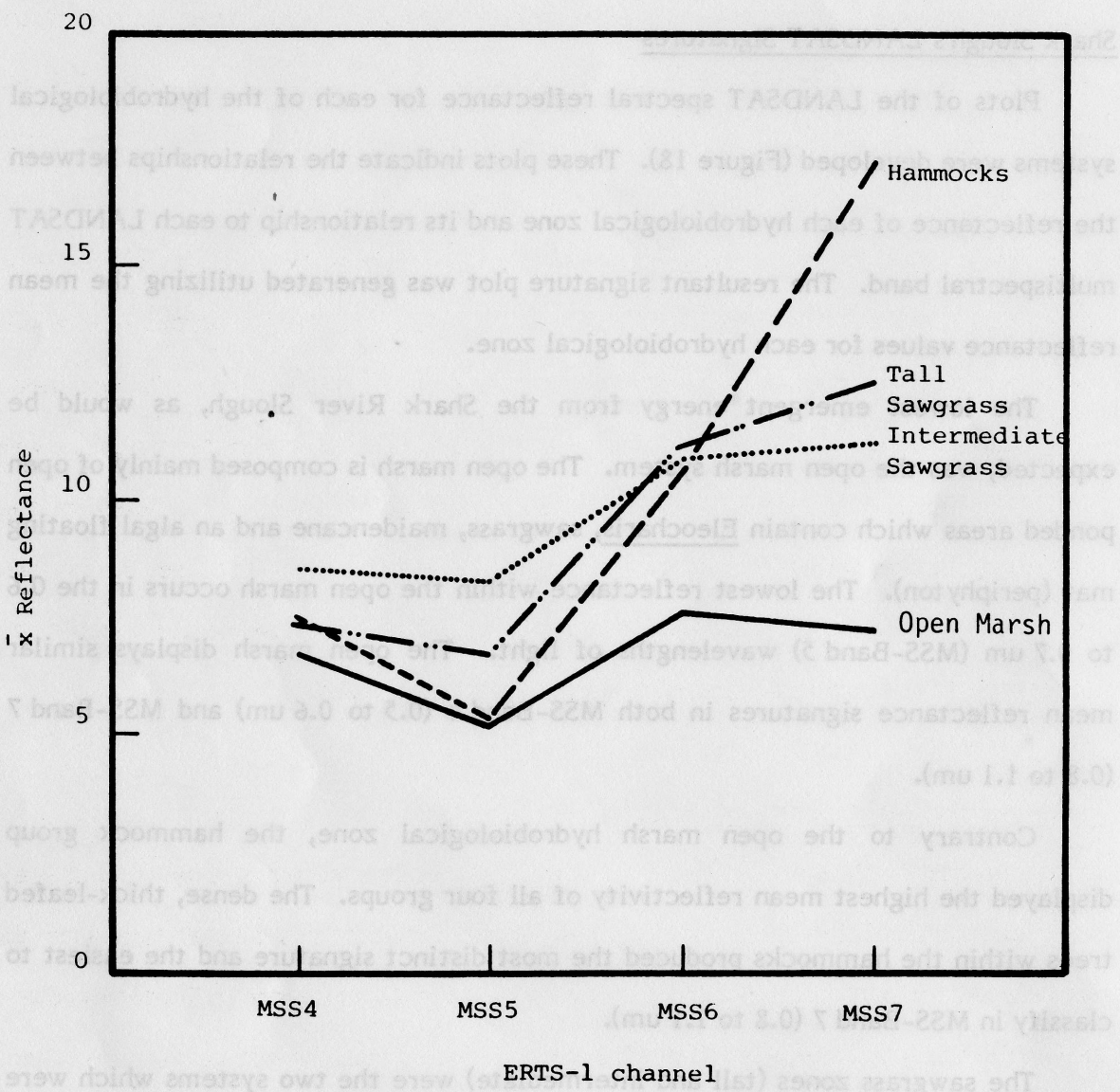

Figure 18. LANDSAT signatures of Shark Slough.

intermediate sawgrass generating a greater reflectance in MSS-Band 4 than the tall sawgrass (this relationship reverses in the MSS-Band 5 response).

It is clearly evident, based upon the relationships established in this plot that the four hydrobiological zones possess unique LANDSAT signatures in the Shark River Slough. These signatures can be separated quite readily utilizing the far infrared (MSS-7; 0.8 to 1.1 μm) wavelengths of light; the only confusion that could occur is between the two types of sawgrass (tall and intermediate).

The most difficult spectral separation of the hydrobiological zones would be using MSS-Band 6. The plots of LANDSAT signatures for three of the four zones were very similar displaying very little uniqueness. In the MSS-Band 6, the mean reflectance value for the hammocks, tall sawgrass and intermediate sawgrass was about the same. In addition, a separation of hydrobiological zones based on the signatures in the MSS-4 (0.5 to 0.6 μm) band would be futile. The open marsh and hammock systems would separate with little difficulty; however, it would be impossible to spectrally separate the two zones of sawgrass.

Hydrobiological Histograms and Statistics

The ability of the G. E. I-100 to obtain the multispectral channel (band) gray level distributions for the training pixels enabled histograms and statistics to be formulated for each training group. The range of gray levels are indicated on the x axis while the y axis represents the range of pixel counts. These histograms, then, give an indication to both the upper and lower bounds for each training group (hydrobiological zone) defining the spectral distribution which was recorded by the LANDSAT scanning device for each specific zone.

The hydrobiological zone in the Shark River Slough with the highest reflectivity was the hammocks. The spectral bounds ranged from a low of 5 in the red wavelengths of light to a high of 25 in the far infrared (Table 4). This was a result

Table 4. Hammocks: Histograms and Statistics.

HAMMOCKS

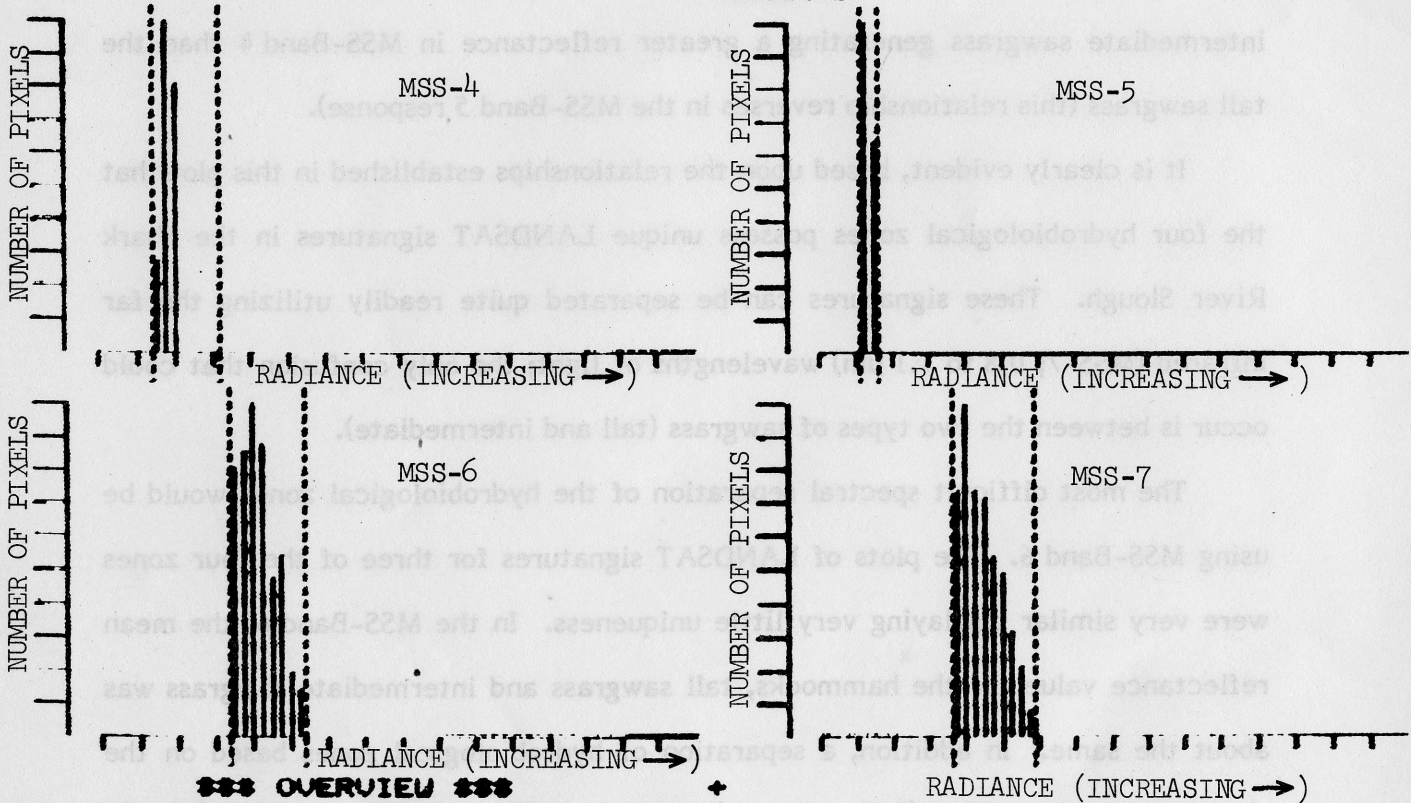

*** OVERVIEW ***

#	LB	UB	DEL	PEAK	MEAN	VAR
1	8	12	7	9879.	7.3	0.5
2	5	6	2	12524.	5.4	0.2
3	14	21	8	4200.	16.5	3.5
4	15	23	9	4264.	17.7	4.5

TRAINING AREA= 20530. PIXELS
 ALARMED AREA= 22030. PIXELS (8.4%)
 TYPE: CHANNEL # OR E(X)IT

*** ONE DIMENSIONAL TRAINING - REV. A ***

CHANNEL	EFFECTIVE RESOLUTION	BOUND-THRESHOLDS(%)			START LEVEL	FINISH LEVEL
		LOW	INC'D	HIGH		
1	64	0.00	(100.00)	0.00	0	63
2	64	0.00	(100.00)	0.00	0	63
3	64	0.00	(100.00)	0.00	0	63
4	64	0.00	(100.00)	0.00	0	63

/// TRAINING IN PROGRESS ///

/// TRAINING COMPLETE ///

CHANNEL	SPECTRAL-BOUNDS	DELTA	PEAK	MEAN	VARIANCE
1	6- 12)	7	9879.	7.26	0.45
2	5- 6)	2	12524.	5.39	0.24
3	14- 21)	8	4200.	16.50	3.50
4	15- 23)	9	4264.	17.74	4.45

TRAINING AREA= 20530.
 ALARMED AREA= 22030. (8.5%)
 PARALLELEPIPED CELLS= 1008.
 FIGURE OF MERIT= 10844.

of the dense, luxuriant plant growth occurring in the hammocks thus producing the greatest spectral spread compared to the alternative hydrobiological zones.

In contrast, as would be expected, the open marsh displayed the lowest reflectance values of the four groups (Table 5). This reflectance occurred in the MSS-Band 5 indicating a low of 5. Conversely, the greatest reflectance in the open marsh was encountered in the infrared (near and far) wavelengths of light which registered a maximum of 9 in both bands.

Situated between these two zones were both the tall and intermediate sawgrass systems (Tables 6 and 7). The tall sawgrass growing denser and displaying larger leaves achieved greater reflectance values than did the intermediate sawgrass. In addition, the tall sawgrass had a slightly lower reflectance value in Bands MSS-4/5 compared to the intermediate sawgrass.

Spectral Relationships in a Wetland Environ

One of the best methods of distinguishing each hydrobiological zone from the other is by contrasting the mean reflectance of two MSS-bands. This technique generates a reflectance plot which readily identifies those bands which are ideal for separating classes (hydrobiological zones). The plot takes into consideration the mean reflectance, upper spectral limits and the lower limits of each class. A double mass curve is then utilized to establish the relationships between two LANDSAT bands.

Spectral reflectance plots were developed for the Shark River Slough's hydrobiological systems. Double mass curves were generated for all maximum combinations of the spectral bands. This enabled an analysis to be formulated for class separation for the combinations of MSS-4 vs. MSS-5; MSS-4 vs. MSS-6; MSS-4 vs. MSS-7; MSS-5 vs. MSS-6; MSS-5 vs. MSS-7; and, MSS-6 vs. MSS-7 (Figure 19).

Table 5. Open Marsh: Histograms and Statistics.

OPEN MARSH

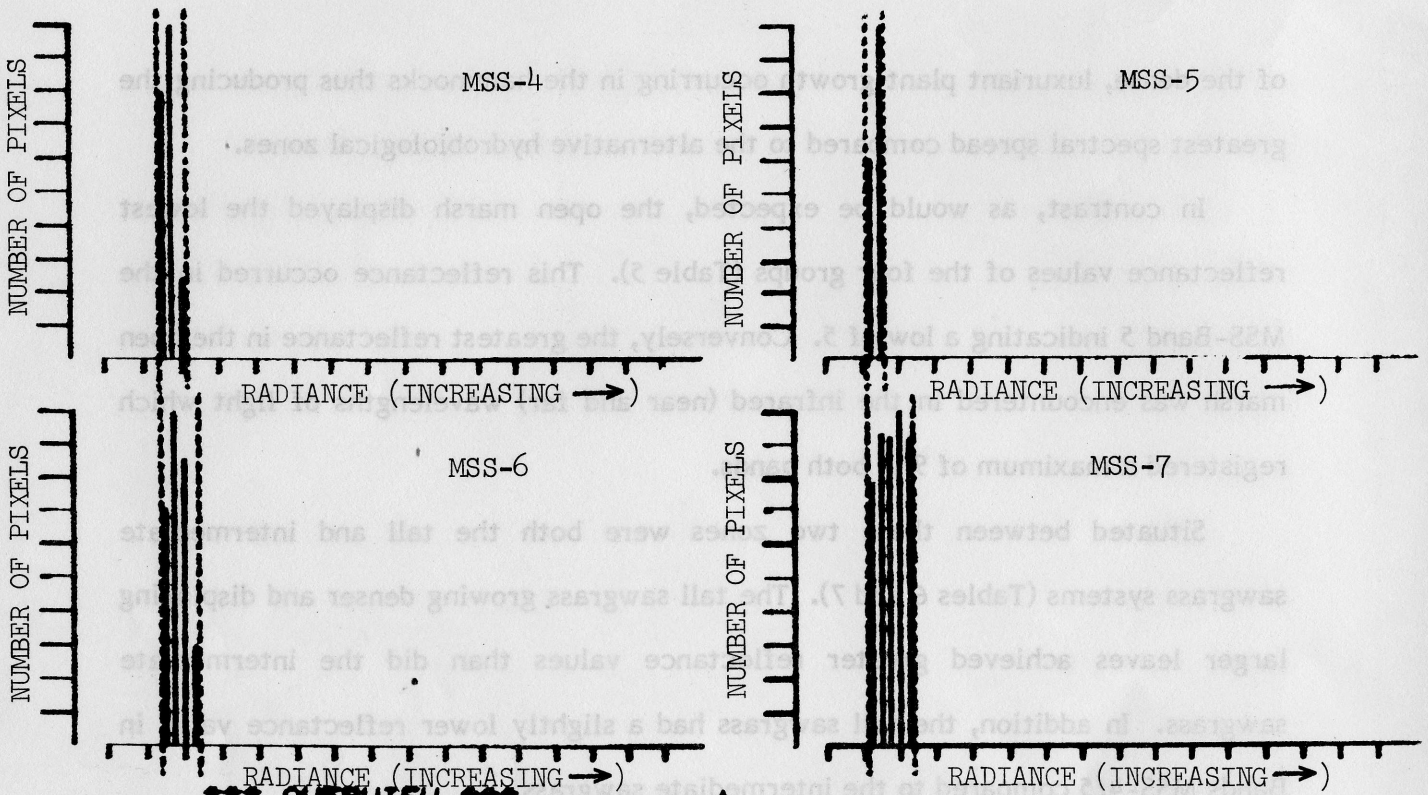

```

*** OVERVIEW ***
#  LB  LB DEL  PEAK  MEAN  VAR  +
1  6   8   3   5024.  6.7  0.4  +
2  8   6   2   6392.  5.6  0.2  +
3  8   9   4   3578.  7.3  0.9  +
4  5   9   5   2252.  7.1  1.9  +
TRAINING AREA= 10235. PIXELS  +
ALARMED AREA= 10235. PIXELS( 3.9%) +
TYPE: CHANNEL 8 OR E(X)IT
    
```

*** ONE DIMENSIONAL TRAINING -REV. A- ***

CHANNEL	EFFECTIVE RESOLUTION	BOUND-THRESHOLDS(X)			START LEVEL	FINISH LEVEL
		LOW	INC'D	HIGH		
1	64	0.00	(100.00)	0.00	0	63
2	64	0.00	(100.00)	0.00	0	63
3	64	0.00	(100.00)	0.00	0	63
4	64	0.00	(100.00)	0.00	0	63

```

/// TRAINING IN PROGRESS ///
/// TRAINING COMPLETE  ///
    
```

CHANNEL	SPECTRAL-BOUNDS	DELTA	PEAK	MEAN	VARIANCE
1	(6- 8)	3	5024.	6.73	0.43
2	(5- 6)	2	6392.	5.62	0.23
3	(6- 9)	4	3578.	7.26	0.89
4	(5- 9)	5	2252.	7.08	1.91

```

TRAINING AREA= 10235
ALARMED AREA= 10235. ( 3.9%)
PARALLELEPIPED CELLS= 120
FIGURE OF MERIT= 139810.
    
```

Table 6. Tall Sawgrass: Histograms and Statistics.

TALL SAWGRASS

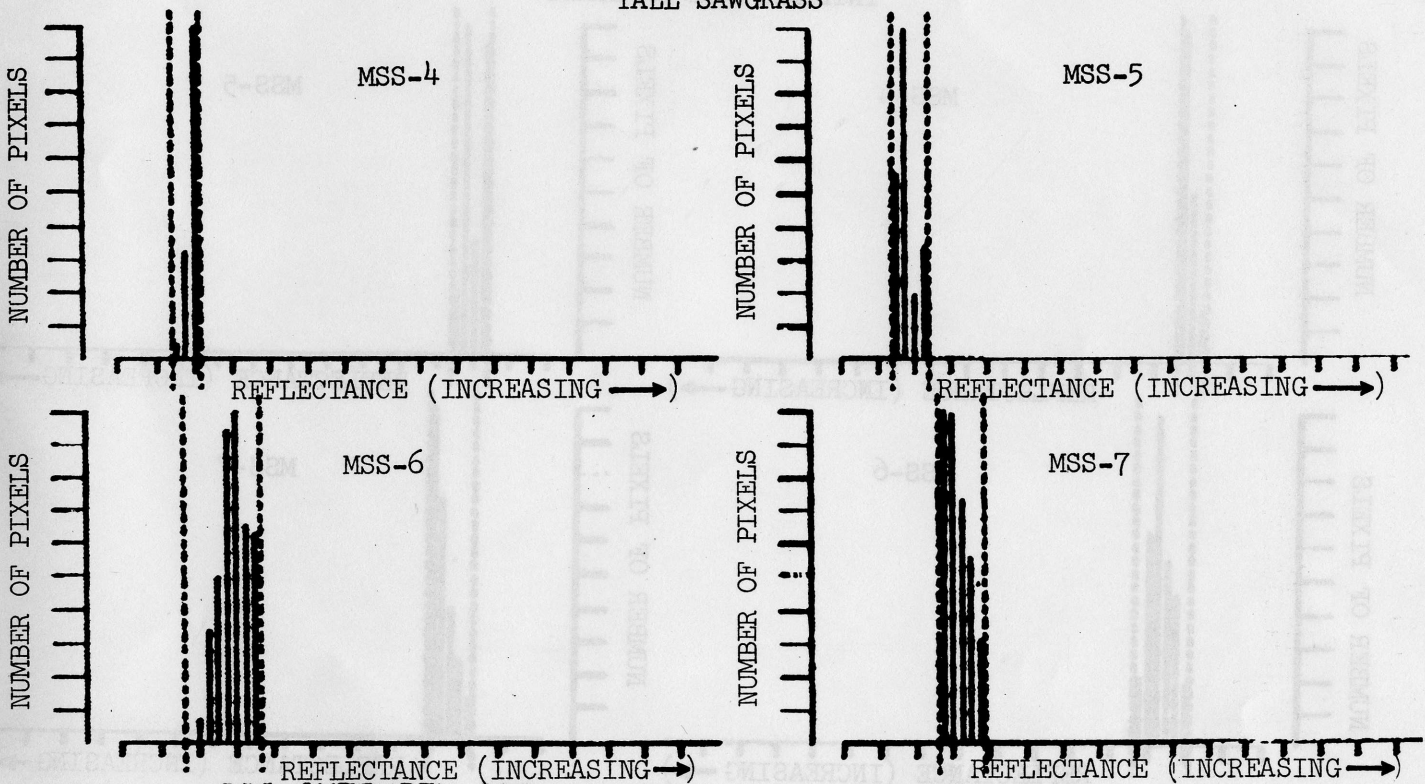

*** OVERVIEW ***

#	LB	UB	DEL	PEAK	MEAN	VAR
1	6	8	3	20107.	7.7	0.3
2	6	9	4	13084.	7.2	1.0
3	7	14	8	6633.	11.7	2.4
4	11	15	5	7630.	12.8	1.6

TRAINING AREA- 27403. PIXELS +
 ALARMED AREA- 27403 PIXELS (10.5%) +
 TYPE: CHANNEL # OR E(X)IT

*** ONE DIMENSIONAL TRAINING -REV. A- ***

CHANNEL	EFFECTIVE RESOLUTION	BOUND-THRESHOLDS(X)			START LEVEL	FINISH LEVEL
		LOW	INC'D	HIGH		
1	64	0.00	(100.00)	0.00	0	63
2	64	0.00	(100.00)	0.00	0	63
3	64	0.00	(100.00)	0.00	0	63
4	64	0.00	(100.00)	0.00	0	63

/// TRAINING IN PROGRESS ///

/// TRAINING COMPLETE ///

CHANNEL	SPECTRAL-BOUNDS	DELTA	PEAK	MEAN	VARIANCE
1	(6- 12)	7	20106.	7.70	0.27
2	(6- 9)	4	13084	7.15	0.90
3	(7- 14)	8	6633.	11.65	2.20
4	(11- 15)	5	7630.	12.80	1.64

TRAINING AREA- 27403.
 ALARMED AREA- 81868 (31.5%)
 PARALLELEPIPED CELLS- 1100.
 FIGURE OF MERIT- 14000.

Table 7. Intermediate Sawgrass: Histograms and Statistics.

INTERMEDIATE SAWGRASS

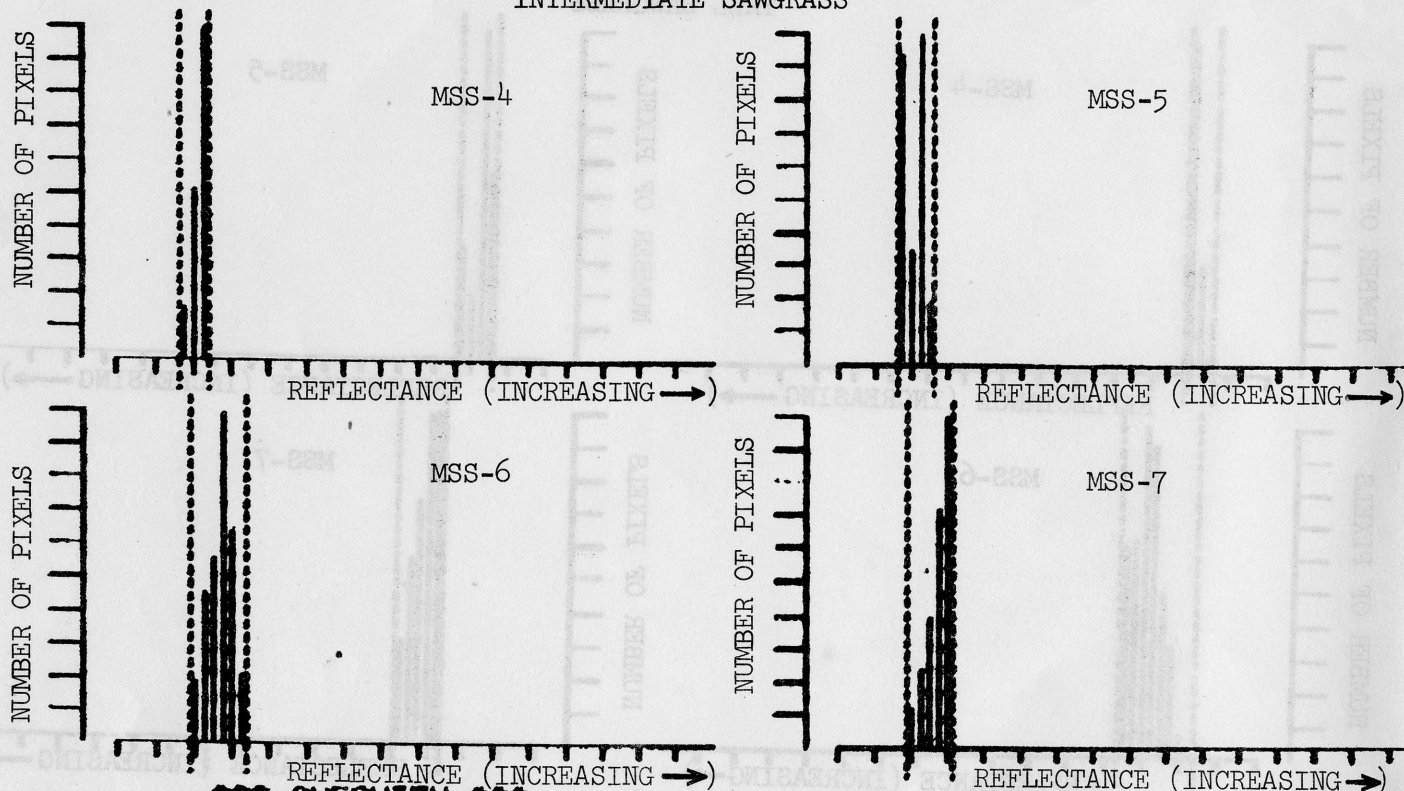

*** OVERVIEW ***

#	LB	UB	DEL	PEAK	MEAN	VAR
1	7	9	3	33043.	8.5	0.4
2	7	10	4	22360.	8.8	1.1
3	8	13	6	18078.	10.7	1.7
4	8	12	5	22346.	10.9	1.4

TRAINING AREA= 55130. PIXELS
 ALARMED AREA= 55130. PIXELS (21.0%)
 TYPE: CHANNEL # OR E(X)IT

*** ONE DIMENSIONAL TRAINING -REJ. A- ***

CHANNEL	EFFECTIVE RESOLUTION	BOUND-THRESHOLDS(%)			START LEVEL	FINISH LEVEL
		LOW	INC'D	HIGH		
1	64	0.00	(100.00)	0.00	0	63
2	64	0.00	(100.00)	0.00	0	63
3	64	0.00	(100.00)	0.00	0	63
4	64	0.00	(100.00)	0.00	0	63

/// TRAINING IN PROGRESS \\
 \\\ TRAINING COMPLETE ///

CHANNEL	SPECTRAL-BOUNDS	DELTA	PEAK	MEAN	VARIANCE
1	(7- 9)	3	33043.	8.51	0.43
2	(7- 10)	4	22360.	8.19	1.06
3	(8- 13)	6	18078.	10.68	1.72
4	(8- 12)	5	22346.	10.91	1.38

TRAINING AREA= 55130.
 ALARMED AREA= 55130. (21.2%)
 PARALLELEPIPED CELLS= 360.
 FIGURE OF MERIT= 46603.

SPECTRAL REFLECTANCE PLOTS

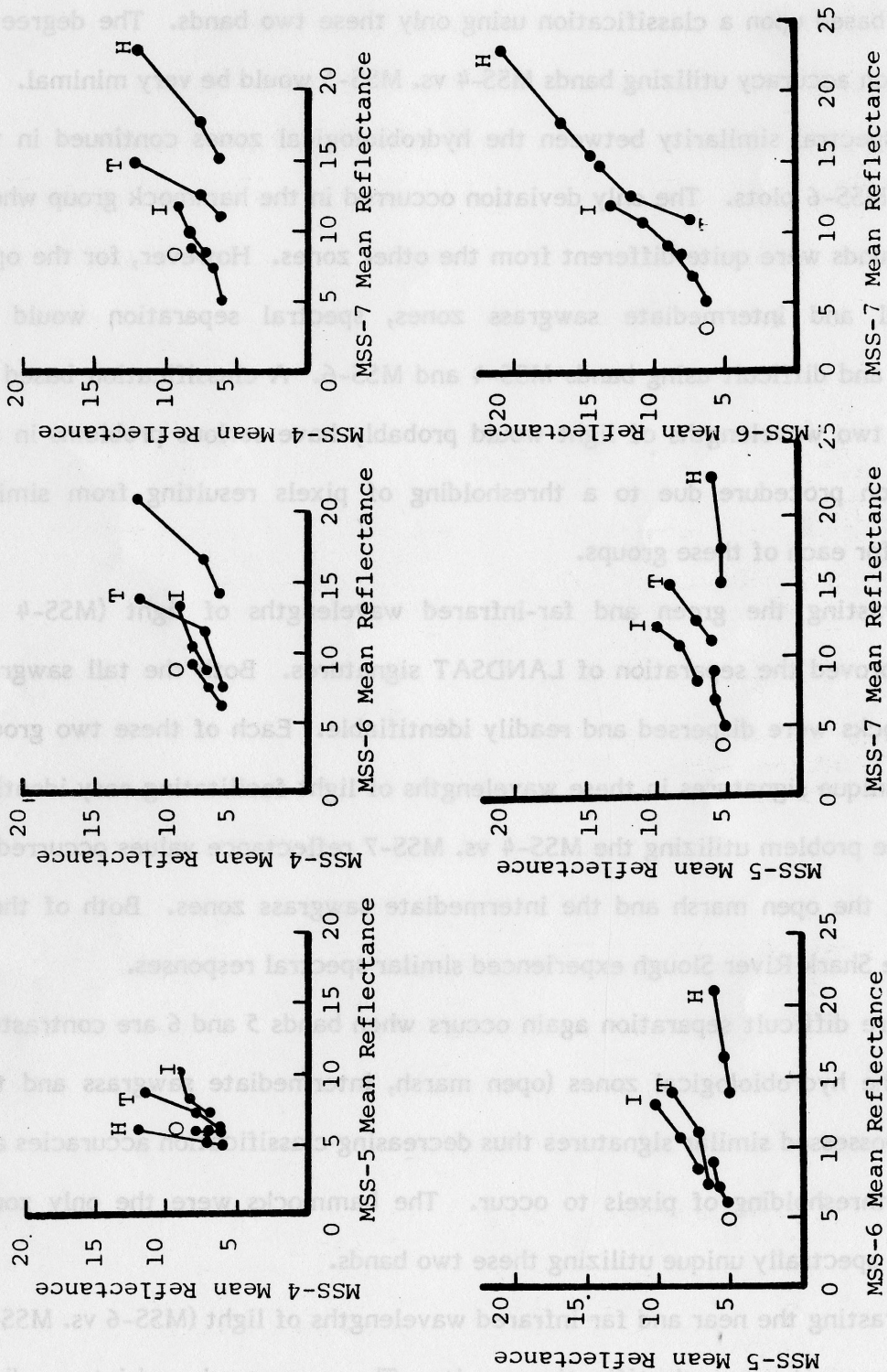

O= Open Marsh, I= Intermediate Sawgrass, T= Tall Sawgrass, H= Hammocks

Figure 19. Spectral Reflectance Plots for Shark Slough's Hydrobiological Zones

Plotting bands MSS-4 vs. MSS-5 produced a tightly clustered grouping for all four hydrobiological zones. The spectral means and extremes were clustered about one-another. The separation of any of these hydrologically active areas would be impossible based upon a classification using only these two bands. The degree of classification accuracy utilizing bands MSS-4 vs. MSS-5 would be very minimal.

The spectral similarity between the hydrobiological zones continued in the MSS-4 vs. MSS-6 plots. The only deviation occurred in the hammock group whose spectral bounds were quite different from the other zones. However, for the open marsh, tall and intermediate sawgrass zones, spectral separation would be inaccurate and difficult using bands MSS-4 and MSS-6. A classification based on only these two wavelengths of light would probably have serious problems in the classification procedure due to a thresholding of pixels resulting from similar signatures for each of these groups.

Contrasting the green and far-infrared wavelengths of light (MSS-4 vs. MSS-7) improved the separation of LANDSAT signatures. Both the tall sawgrass and hammocks were dispersed and readily identifiable. Each of these two groups possessed unique signatures in these wavelengths of light facilitating easy identification. The problem utilizing the MSS-4 vs. MSS-7 reflectance values occurred in contrasting the open marsh and the intermediate sawgrass zones. Both of these areas in the Shark River Slough experienced similar spectral responses.

A more difficult separation again occurs when bands 5 and 6 are contrasted. Three of the hydrobiological zones (open marsh, intermediate sawgrass and tall sawgrass) possessed similar signatures thus decreasing classification accuracies and increasing thresholding of pixels to occur. The hammocks were the only zones which were spectrally unique utilizing these two bands.

Contrasting the near and far infrared wavelengths of light (MSS-6 vs. MSS-7) also would generate poor classification results. The open marsh and intermediate sawgrass classes overlap where the upper limits of the marsh and the lower limits

of the sawgrass plot. In addition, the proximity of the upper limits of the tall sawgrass and the lower limits of the hammocks would render classification difficult.

The best possible classification of the hydrobiological zones in the Florida Everglades would be through utilizing the MSS-5 vs. MSS-7 bands (0.6 to 0.7 um vs. 0.8 to 1.1 um). These two bands were the only suitable combination which allowed complete spectral separation of these zones. The plot clearly indicates the separability and diffusion of the mean spectral relationships for all LANDSAT band combinations. The class separation of the hydrobiological zones in MSS-5 vs. MSS-7 clearly indicates the spectral uniqueness of each signature which would enable accurate and detailed automated extraction from machine processors to be accomplished. Thus, for a given hydrobiological zone a mean reflectance value can be defined utilizing MSS-5 band vs. MSS-7 band for open marsh, intermediate sawgrass, tall sawgrass and hammocks, and these values are unique enabling analysis to be formulated (Figure 20).

Hydrobiological Classification of the Shark River Slough

Classification of the hydrobiological systems in the Shark Slough was accomplished using the G. E. I-100. This interactive multi-data processor utilized all four multispectral bands during the automated interactive mapping process. The signatures were readily identified and extracted using primarily the single-cell signature acquisition mode. This procedure generated a complete hydrobiological classification of the Shark River Slough in Everglades National Park. Each hydrobiological zone was isolated and mapped accordingly, as well as a composite classification depicting all four zones. Each map clearly and accurately delineated each hydrologically active slough system.

of the sawgrass plot. In addition, the proximity of the upper limits of the tall sawgrass and the lower limits of the hammocks would render classification difficult.

The best possible classification of the hydrobiological zones in the Florida Everglades would be through utilizing the MSS-5 vs. MSS-7 bands (0.6 to 0.7 um vs. 0.8 to 1.1 um). These two bands were the only suitable combination which allowed

complete spectral separation of these zones. The plot clearly indicates the separability of the mean spectral relationships for all LANDSAT band combinations.

MSS-7 clearly indicates the spectral uniqueness of each hydrobiological zone which would enable accurate automated extraction from the data processor to be accomplished. Thus, for a given hydrobiological zone a reflectance value can

be defined utilizing MSS-5 band vs. MSS-7 band for open marsh, intermediate sawgrass, tall sawgrass and hammocks and these values are unique enabling analysis to be formulated (Figure 20).

Classification of the hydrobiological systems in the Shark Slough was accomplished using the G.E.I-100. This interactive multi-data processor utilized all four multispectral bands during the automated interactive mapping process.

The signatures were readily identified and extracted using primarily the single-cell signature extraction technique. The unique spectral signatures of each hydrobiological zone were isolated and mapped accordingly, as well as a composite classification depicting all four zones. Each map clearly and accurately delineated each hydrobiologically active slough system.

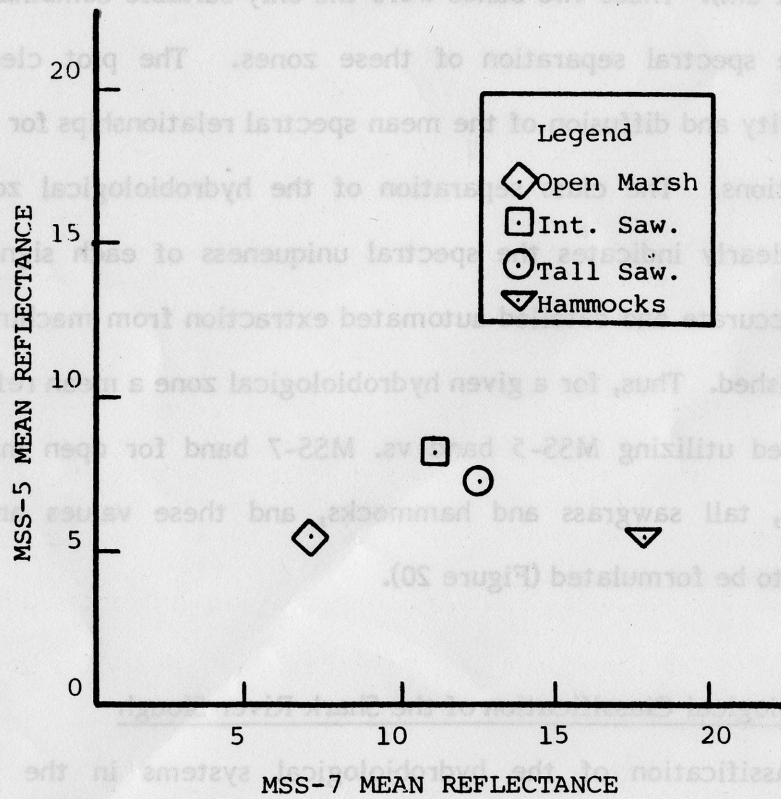

Figure 20. MSS-7 vs. MSS-5 Mean Reflectance Values Separating all Hydrobiological Zones, Shark River Slough.

The classification of the March 3, 1975 overflight mapped the open marsh system as would be expected during the dry season. The ponded water was primarily centered about the central conduit of the Shark Slough. In addition, ponded water in the Conservation Area 3-A adjacent to and north of the park was accounted for by the classifier.

The predominant hydrobiological system in the Shark Slough during the dry season is the intermediate sawgrass group. This sawgrass zone is dispersed throughout the slough to the mangrove fringe. The influence of the intermediate sawgrass on the movement of water throughout the slough becomes apparent on the classification results (refer to enclosures in cover).

One of the predominant patterns associated with the Florida Everglades are the large "teardrop" shapes associated with the hammocks. The hammocks sweep in an arching fashion throughout the park and were readily identified by the processor. The tall sawgrass was delineated as is encountered in the field -forming the "tails" of the hammocks, isolated strands and increasing in magnitude near the mangrove fringe.

Each hydrobiological system was also delineated on a computer hard-copy printout which isolated each specific zone. This hard-copy was then photographically enlarged to a scale of 1:130,000 which rendered better definition for each zone and enabled more accurate flow vectors to be determined. In addition, the computer furnished total pixel counts which could then be applied to determine the relative area represented by each specific hydrologically active zone.

According to Kushlan, et al., 1975, the Shark Slough encompasses a total of 142,579 square acres (222.78 mi^2 or 577 km^2). This includes the area south of the

Tamiami Trail (U.S. 41) and to the west of L-67 (not including lands outside of the park in the N.E. Shark Slough) (Figure 11). The classification of the Shark Slough determined that intermediate sawgrass is by far the greatest hydrobiological system in the slough, comprising 76 percent of the total area (Table 8). Both the tall sawgrass and open marsh systems were comparable (11 percent and 10 percent, respectively) for this period of the dry season, and the hammocks were only 3 percent of the total area in the Shark River Slough.

There are two facets which must be considered when analyzing these data concerning total aerial extent of each zone. First, the margins of the slough contract and expand in response to hydrological inputs throughout the year. During the dry season, reduced water deliveries to Everglades National Park combined with minimal rainfall contributions is responsible for contractions of the slough's margins. Conversely, during the wet season the margins of the slough expand in direct response to greater water deliveries and rainfall inputs.

Second, the minimum resolution capability of the LANDSAT pixel cell is 1.1 acres. This translates to an average radiance value for an area of land which is contained within the limits of the pixel. Therefore, an area which is composed of both small areas of open marsh surrounded by large areas of intermediate sawgrass will display and be classified according to the reflectance characteristics of the predominant grouping.

Consideration of both these problems enables a better understanding of the determined percentages and aerial extent for each zone to be formulated. This is especially true of the 10 percent coverage for the open marsh system. As the slough expands in response to the subsequent wet season, so should the aerial extent of the open marsh. Of all four hydrobiological zones, the open marsh should change the greatest spatially because as the greater water depths develop, the slough will display the characteristics most common to a water system rather than

Table 8. Dry Season Classification Results for Total Area of Each Hydrobiological System, Shark Slough.

DRY SEASON CLASSIFICATION RESULTS: TOTAL AREA

Hydrobiological Zone	Percent	Square Acres	Square Miles	Square Km
Intermediate Sawgrass	76	108,360	169	438.52
Tall Sawgrass	11	15,684	25	63.47
Hammocks	3	4,277	7	17.31
Open Marsh	10	14,258	22	57.70
TOTAL		142,579	222.78	577

the vegetative system which is predominant in the dry season. Therefore, it would be expected that the total area classified as intermediate sawgrass would become smaller and the open marsh would increase. This trend should reverse as the dry season again approaches, approximating the percentages generated during this classification procedure.

Accuracy Assessment

The spectral response of a wetland area such as the Shark River Slough, contains unique signatures which can be successfully classified. The degree of accuracy was found to be very high for each hydrobiological zone in the slough which thereby increased the confidence levels for the overall classification.

The highest classification accuracies were for two areas: the open marsh and the hammocks (Table 9). The other two groups (intermediate sawgrass and tall sawgrass) encountered some misclassification problems, however, the lowest accuracy was at the 93 percentile level.

Both the open marsh and the hammock areas experienced the greatest success primarily because of the unique spectral response and spread which separated them from the other groups. The low reflectivity of the water and the high spectral response of the hammocks (especially in the near and far infrared) enabled an extremely accurate classification to be developed.

The accuracy assessment for the sawgrass groups indicated some confusion problems between tall sawgrass and the intermediate sawgrass. Because tall sawgrass has a slightly higher reflectivity in most cases, the classifier was able to isolate this grouping 96 percent of the time. However, because of the similarity between the lower reflectance values for the tall sawgrass and the upper reflectance limits for the intermediate sawgrass, the classifier had difficulty in distinguishing between these two groups.

Table 9. Overall Classification Accuracy for Each Hydrobiological Zone in the Shark Slough*

Training Site	Water	Hammock	Intermediate Sawgrass	Tall Sawgrass	% Accuracy
Water	118	0	0	0	100
Hammock	0	10	0	0	100
Intermediate Sawgrass	1	0	810	55	93
Tall Sawgrass	0	6	0	152	96

TOTAL AVERAGE PERCENT ACCURACY 97.25

* number of pixel samples per group.

The percent accuracy for the intermediate sawgrass was the lowest of the four hydrobiological systems. The classifier correctly recognized the intermediate sawgrass 93 percent of the time. Except for one pixel which was classified as open marsh, all others were misclassified into the tall sawgrass group. However, the misclassifications which occurred in the tall sawgrass group were not caused by the confusion with the intermediate sawgrass but rather the hammock group. Therefore, 7 percent of the time the classifier confused intermediate sawgrass for tall sawgrass and 4 percent of the time the classifier confused tall sawgrass with the hammocks.

Determination of Conceptual Flow Vectors for the Shark River Slough

The classifications generated by this remote sensing project were of importance for spatially determining the conceptual flow vectors for the slough. These vectors schematically depict the relative rates and distribution of surface water movement through the slough for that particular stage (water level). This initial attempt at conceptually modelling surface water flows throughout the Shark Slough will be of significance to future three-dimensional computer modelling efforts to be conducted for the slough's water system.

The direction of surface flow was determined at 26 selected sites throughout the Shark Slough (Figure 21). The test locations were first plotted on aerial photographs and then a helicopter was utilized to transport personnel to the test locations. A Rhodamine tracer dye was placed into the water column and a compass bearing was made once the dye had traveled far enough to indicate the direction of water flow (without wind interference). Also taken into consideration was the wind speed and wind direction.

As would be expected, the general direction of water movement throughout the slough lies parallel with the axis of the vegetation strands (hammocks and the teardrop sawgrass areas) (Figure 22). Even at the slough's margins, the flow



Figure 21. Selected test sites in Shark Slough for surface flow determinations

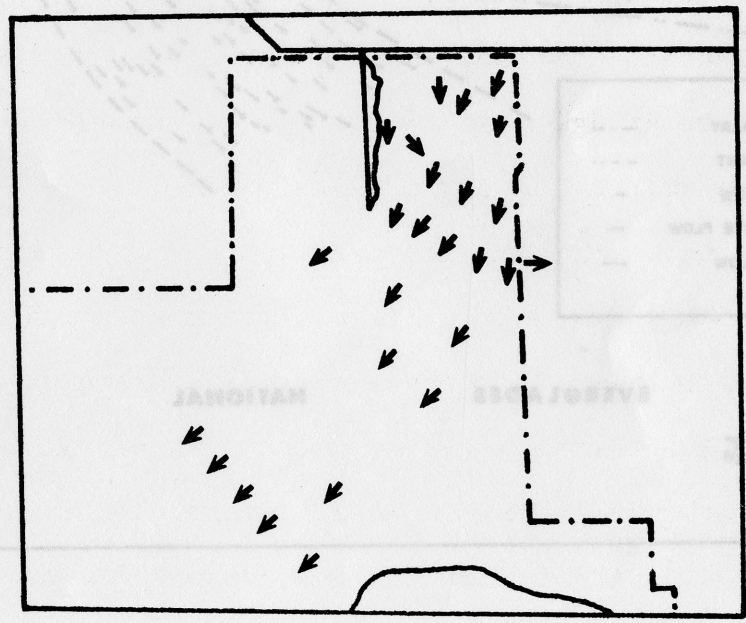

Figure 22. Direction of surface water flow measured in Shark Slough

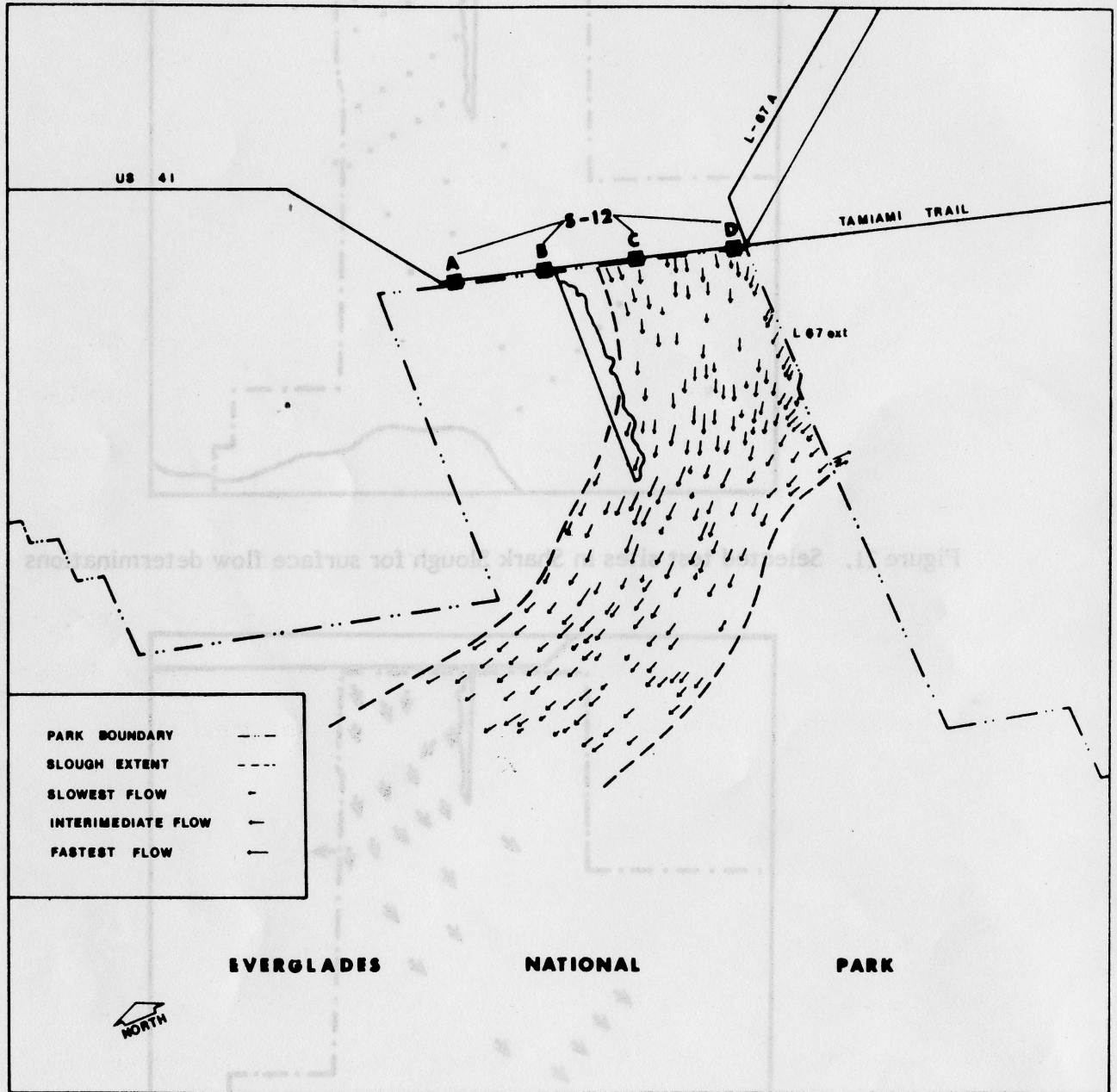

Figure 23. Conceptual Flow Vectors for Surface Flow in Shark Slough

continues this general trend rather than draining towards the central conduit of the slough. The only exception to this observation occurred south of, and to the east of, L-67 extension. The surface water flowed in a due easterly fashion into the N.E. Shark Slough (outside the boundaries of ENP) due to the head differential.

Once the direction of flow was established in the Shark Slough then the conceptual flow vectors were plotted utilizing the LANDSAT hydrobiological classification and the compass bearings (Figure 23). A vector was plotted indicating relative water movement and direction throughout the slough system. The percentage of vectors plotted for each hydrobiological zone were directly proportional to the total area classified from the LANDSAT scene. The smallest vectors represent the areas of slowest water movement (tall sawgrass zones). Conversely, the most rapid flow in the Shark Slough is representative of the open marsh system and is designated with the longest vector. The final conceptual flow vectors map generated better defines, spatially, the characteristics of overland sheet flow in the Shark Slough which will enable a better understanding of the slough system to be formulated and applied to the future modelling efforts.

CONCLUSIONS

The application of LANDSAT imagery for hydrologic applications in a wetlands area, such as the Shark River Slough in Everglades National Park is definitely a viable tool for resource management. The ability to monitor both spatially and temporally, the dynamic hydrologic conditions has immense ramifications. The water control and modification programs in South Florida have interrupted the natural hydrologic regime of the park and made the monitoring of hydrologic parameters mandatory. Through the applications of remotely sensed

data, both the spatial and temporal aspects of the slough's hydrologic conditions can be better understood in a "real time" sequence. This will be of significance to both ecosystem maintenance and preservation through the generation of appropriate ecological models for the Florida Everglades ecosystem.

Once the earth-sun relationships have been established and the physics of light interaction and the slough's environment understood, the resource manager will be able to develop a sophisticated remote sensing inventory program based on field data taken from point measurements and other suitable forms of ground truth. Good aerial photography coverage and the establishment of intensive study areas are important in computer training/classification procedures. Whether the training is accomplished by a supervised or unsupervised approach, the most critical stage of the training procedure involves training the computer to accurately recognize all signatures within the scene and classify them accordingly.

In regards to wetlands applications, a multispectral processing system can, with a great degree of accuracy, determine LANDSAT signatures for critical zones within a marsh environment. LANDSAT signatures can be plotted for each band developing relationships between mean reflectance and each multi-spectral channel (band). These relationships can be determined by a detailed analysis of the input statistics which generate histograms and give a statistical analysis for each training group. In addition, these statistics can be utilized to develop spectral reflectance plots which distinguish one class from another by contrasting mean reflectance values of two multispectral (MSS) bands of the LANDSAT satellite. The resultant classification can then be of significance for further hydrologic applications, such as determining the hydrologically active areas within a wetlands environment, establishing flow vectors for any marsh area, determining the contracting/expanding margins of the slough and finally determining total volume of water stored in a wetlands area.

Remote sensing can provide greater perspective into the intricate hydrologic events that occur in Everglades National Park. This information then, can provide valuable insight into the complex South Florida ecosystem enabling a sounder resource management program to be formulated which will ultimately benefit the park's ecosystem and enhance the park experience for the visitor.

Barolucci, Luis A., Barrett F., Roberson and Leroy F. Silva. "Field Measurement of the Spectral Response of Natural Waters", Photogrammetric Engineering, Vol. XLIII, 45, May, 1977.

Erp, R. Bryan. BRTS-1 Coastal/Estuarine Analysis, Investigation (ER-600), Vol. II, NASA TMX-5814, Johnson Space Center, Houston, Texas, 1974.

General Electric Company. Systems Descriptions Image-100, Ground Systems Department, Space Division, Daytona Beach, Florida, Document No. 7170012D, 1975.

Hall, Royce N., Ken G. McGuire and Roy A. Bland. Landstar Signature Development Program, Unpublished, NASA-KSC, Florida.

Higer, Aaron L., A. Eugene Coker and Edwin H. Cordes. Ecological Model in Florida, USGS, 1975.

Kolipinski, Milton C. and Aaron L. Higer. "Inventory of Hydrobiological Features Using Automatically Processed Multispectral Data", USGS, Proceedings of the 6th International Symposium on Remote Sensing of Environment, 1969.

Kushian, James A., John C. Ogden and Aaron L. Higer. Relation of Water Level and Fish Availability to Wood Stork Reproduction in the Southern Everglades, Florida, Open-File Report 75-434, Tallahassee, Florida, 1975.

REFERENCES

- Anderson, Richard R. and Virginia Carter. "Wetlands Delineation by Spectral Signature Analysis and Legal Implications," Fourth Annual Earth Resources Program Review, Vol. III, USGS, Houston, Texas, 1972.
- Bartolucci, Luis A., Barrett F. Robenson and LeRoy F. Silva. "Field Measurement of the Spectral Response of Natural Waters," Photogrammetric Engineering, Vol. XLIII, #5, May, 1977.
- Erb, R. Bryan. ERTS-1 Coastal/Estuarine Analysis, Investigation (ER-600), Vol. II, NASA TMX-5818, Johnson Space Center, Houston, Texas, 1974.
- General Electric Company. Systems Descriptions Image-100, Ground Systems Department, Space Division, Daytona Beach, Florida, Document No. 717001SD, 1975.
- Hall, Royce N., Ken G. McGuire and Roy A. Bland. Landsat Signature Development Program, Unpublished, NASA-KSC, Florida.
- Higer, Aaron L., A. Eugene Coker and Edwin H. Cordes. Ecological Model in Florida, USGS, 1975.
- Kolipinski, Milton C. and Aaron L. Higer. "Inventory of Hydrobiological Features using Automatically Processed Multispectral Data," USGS, Proceedings of the 6th International Symposium on Remote Sensing of Environment, 1969.
- Kushlan, James A., John C. Ogden and Aaron L. Higer. Relation of Water Level and Fish Availability to Wood Stork Reproduction in the Southern Everglades, Florida, Open-File Report 75-434, Tallahassee, Florida, 1975.

Ritchie, Jerry C., Frank R. Schiebe, and J. Roger McHenry. "Remote Sensing of Suspended Sediments in Surface Waters, "Photogrammetric Engineering, Vol. XLII #12, 1976.

Scherz, James P. "Remote Sensing Considerations for Water Quality Monitoring." Proceedings of the 7th Symposium on Remote Sensing of Environment, Vol. II, 1971.

Tucker, Compton J. and Lee D. Miller. "Soil Spectra Contributions to Grass Canopy Spectral Reflectance. "Photogrammetric Engineering, Vol. XLIII #6, 1977.

Work Edgar A., Jr., et al. "Utilization of Satellite Data from Inventorying Prairie Ponds and Lakes," Photogrammetric Engineering, Vol. XLII #5, 1976.

