

922.0841
DEF
1960-1962

850 ✓

CITY OF MIAMI
Planning Department
LIBRARY
Catalog No. CM 850
Publication No. 11

The CITY PLANNING BOARD
of MIAMI, FLORIDA

4.
CAPITAL IMPROVEMENTS

- 1960-61
- 1961-62

The CITY PLANNING BOARD
of MIAMI, FLORIDA

LIBRARY COPY
The CITY PLANNING BOARD
of MIAMI, FLORIDA

3
Prepared By
The Department of Engineering
City of Miami, Florida
October, 1961

08120
88081

SUMMARY

During the past fifteen months (the 1960-61 fiscal year plus the three month extended budget period), the City of Miami let contracts for Capital Improvements the total cost of which came to \$4,825,000.

Scheduled for the 1961-62 fiscal year (October through September), is an additional \$6,206,000 in improvements.

These are summarized below and discussed in further detail in the following pages.

<u>Type of Improvement</u>	<u>Contracts Let 1960-61</u>	<u>Proposed for 1961-62</u>
Sanitary Sewers	\$1,928,000	\$2,370,000
Storm Sewers	494,000	1,395,000
Recreational Facilities	680,000	515,000
Highways & Streets	1,018,000	861,000
Sidewalks	--	75,000
Structural Improvements	672,000	440,000
City Beautification	33,000	550,000
TOTAL	\$4,825,000	\$6,206,000

In addition to the above, the City improved its street lighting during the period to the extent of an annual increase of \$89,000 to its street lighting budget. During the 1961-62 fiscal year, street lighting will be further improved by an additional \$55,000 increase in the budget.

**CITY PLANNING BOARD
of MIAMI, FLORIDA**

SANITARY SEWERS

1960-61 Improvements

Between July 1, 1960, and September 30, 1961, contracts were let for ten sanitary sewer projects (plus twenty smaller sanitary sewer jobs done by Public Service). The total cost of these improvements was \$1,928,000.

These included five sanitary sewer improvement districts (totaling 17 miles), one trunk main, two pump stations, one expressway modification project, and one infiltration project. A brief summary of these follows.

<u>Quantity</u>	<u>Type of Improvement</u>	<u>Miles</u>	<u>Cost</u>
5	Sanitary Sewer Improvement Districts	17.1	\$1,474,000
2	Pump Stations	--	164,500
1	Trunk Main	.9	254,500
1	Expressway Modification	.2	11,600
1	Infiltration Project	1.8	13,400
20	Miscellaneous small adjustment projects by City forces	--	10,000
	TOTAL	<u>20.0</u>	<u>\$1,928,000</u>

1961-62 Proposed Improvements

Fifteen sanitary sewer projects, totaling \$2,370,000, are proposed for the fiscal year 1961-62. These are as follows:

7 Sanitary Sewer Improvement Districts	\$1,975,000
3 Pump Stations (Renovated or Replaced)	80,000
1 Interceptor	100,000
2 Infiltration Projects	95,000
1 Renovation Project	70,000
1 Modification Project	50,000
	<u>\$2,370,000</u>

SANITARY SEWERS

1960-61 IMPROVEMENTS \$1,928,000

LEGEND

- PREVIOUSLY SEWERED
- CONTRACTS LET 1960 - 61
- PROPOSED CONSTRUCTION 1961 - 62

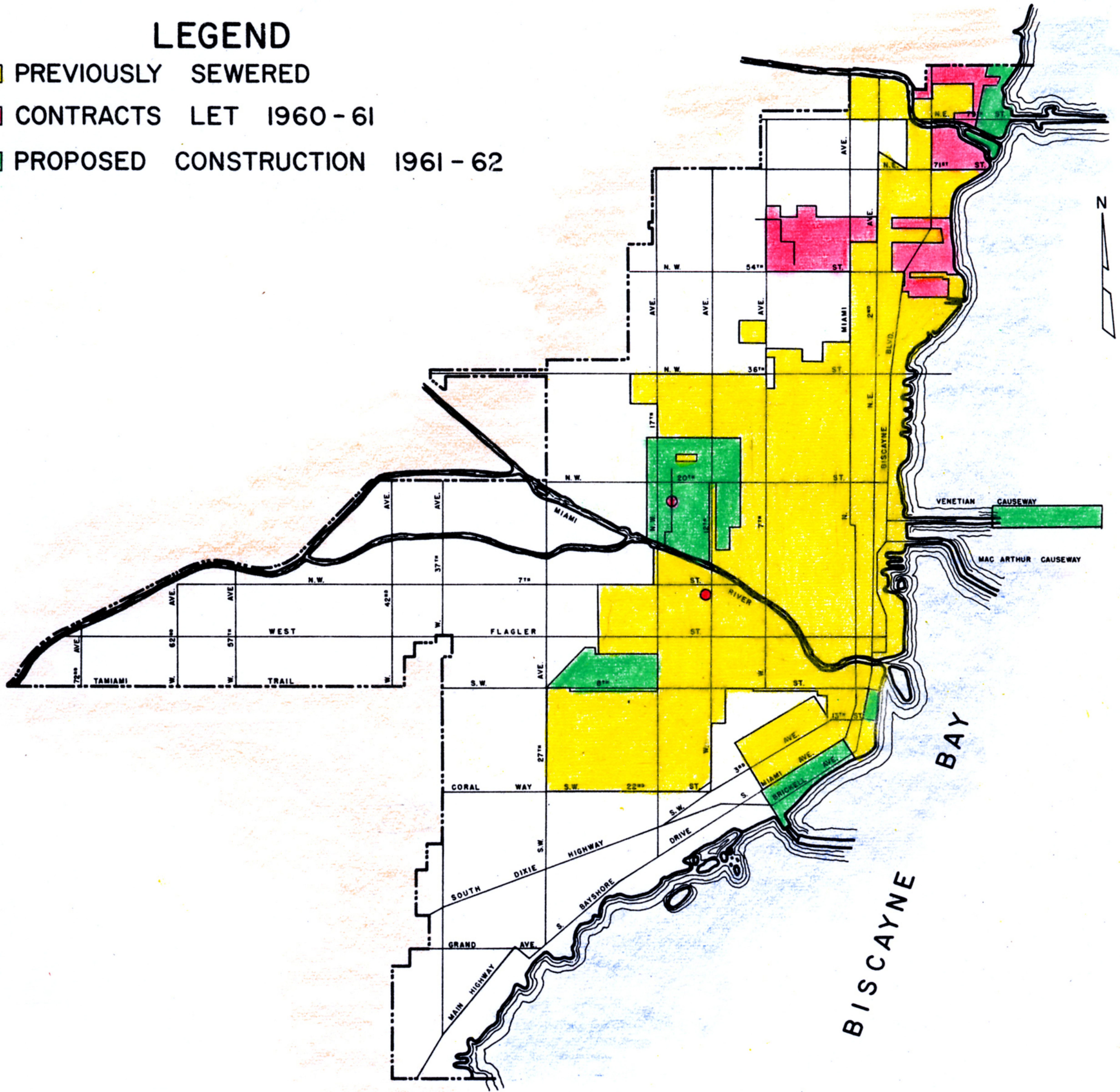

1961-62 PROPOSED IMPROVEMENTS \$2,370,000

STORM SEWERS

1960-61 Improvements

Between July 1, 1960, and September 30, 1961, contracts were let for seven storm sewer projects (plus twenty-seven miscellaneous small local drainage projects done by City forces). The total cost of these improvements was \$494,000.

These included three storm sewer improvement districts, two interceptors, and two local drainage projects.

A brief summary of these follows.

<u>Quantity</u>	<u>Type of Improvement</u>	<u>Miles</u>	<u>Cost</u>
3	Storm Sewer Improvement Districts	1.8	\$275,000
2	Interceptors	.6	85,000
2	Local Drainage Projects	.4	90,000
27	Miscellaneous small local drainage projects by City forces	--	44,000
	TOTAL	<u>2.8</u>	<u>\$494,000</u>

1961-62 Proposed Improvements

A much accelerated storm sewer program is proposed for the fiscal year 1961-62. Included are fourteen items totaling \$1,395,000 as follows:

Eleven Storm Sewer Areas	\$1,115,000
Storm Sewers for Highway Projects	80,000
Local Drainage Program	100,000
Storm Sewer Modifications and Renovations	100,000
	<u>\$1,395,000</u>

STORM SEWERS

1960-61
IMPROVEMENTS

\$ 494,000

LEGEND

- PREVIOUSLY SEWERED
- CONTRACTS LET 1960-61
- PROPOSED CONSTRUCTION 1961-62

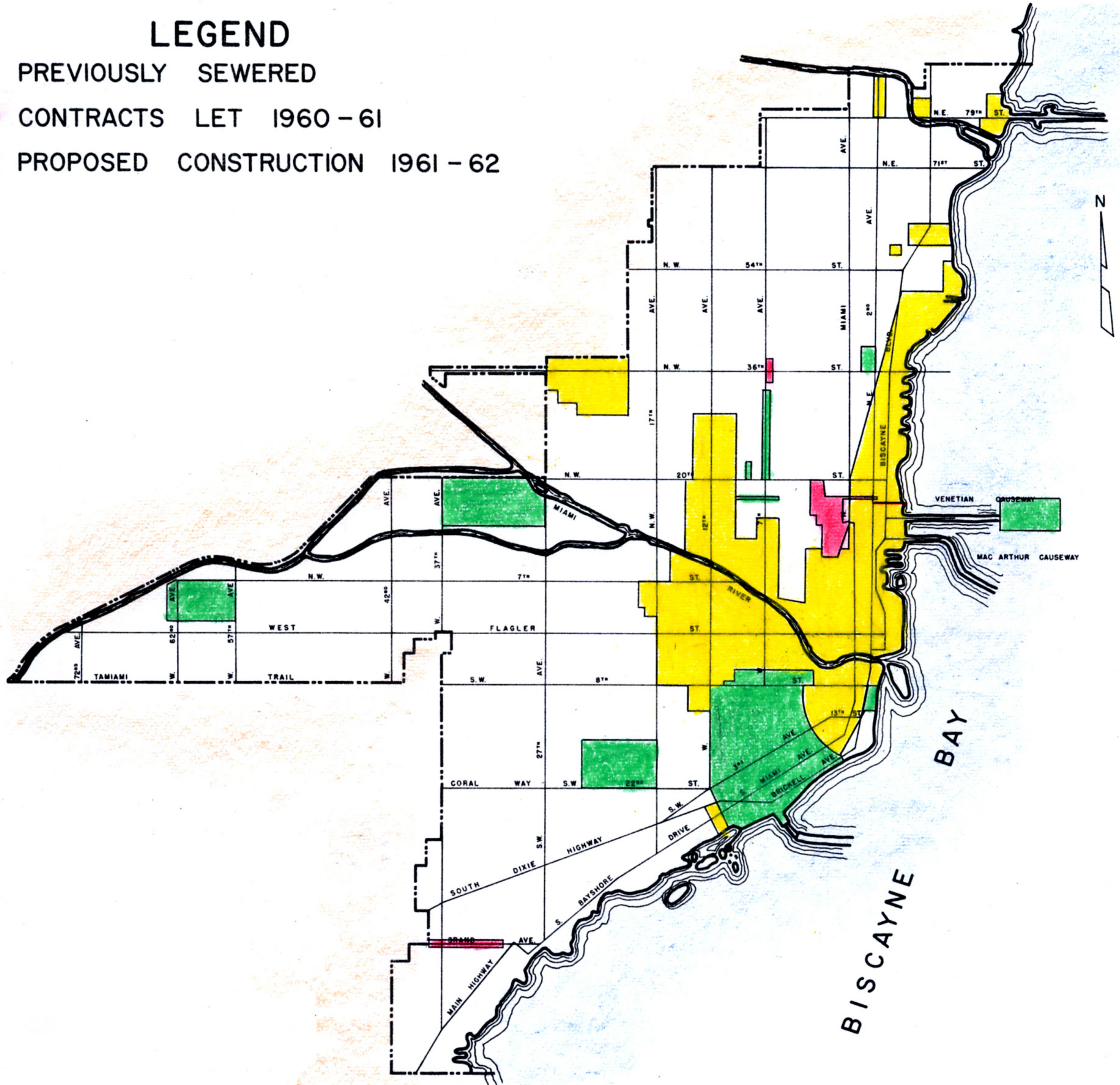

1961-62 PROPOSED
IMPROVEMENTS

\$ 1,395,000

HIGHWAYS AND STREETS

1960-61 Improvements

Between July 1, 1960, and September 30, 1961, twenty-nine contracts were let for paving projects. Adding in the \$166,000 spent for right-of-way acquisition and the several miscellaneous small paving jobs done by City forces, these improvements totaled \$1,018,000. A brief summary of these follows.

<u>Quantity</u>	<u>Type of Improvement</u>	<u>Miles</u>	<u>Cost</u>
6	Remacadamizing Districts	47.2	\$ 415,000
8	Rebuilding Projects	3.4	337,000
15	Special Paving Projects	--	80,000
--	Right-of-Way	--	166,000
8	Miscellaneous projects by City forces	--	20,000
	TOTAL	50.6	<u>\$1,018,000</u>

Special paving projects included such items as turning lanes, and some parking facilities.

Streets which were rebuilt included portions of such streets as Grand Avenue, N. W. 4th Avenue, N. W. 17th Street, and East and West Glencoe Streets.

The forty-seven miles of remacadamizing consisted of 238 streets, predominantly residential.

1961-62 Proposed Improvements

Proposed street improvements for the fiscal year 1961-62 total \$861,000. These can be divided as follows:

<u>Type</u>	<u>Miles</u>	<u>Cost</u>
Full Width Street Development	2	\$341,000
Residential Street Rebuilding	4	125,000
Remacadamizing and Renovating	20	200,000
Miscellaneous Trafficway Improvements	--	50,000
Right-of-Way Acquisition	--	125,000
Bridge (N. E. 10 Ave. & Ademar Canal)	---	20,000
		<u>\$861,000</u>

This does not include the Biscayne Boulevard Plaza Project which is listed under the section on City Beautification.

HIGHWAYS & STREETS

**1960-61
IMPROVEMENTS**

\$1,018,000

LEGEND

1960-61 IMPROVEMENTS: - 50 MILES

 REMACADAMIZING "AREAS" (47 MILES - 238 STREETS)

 STREETS REBUILT (3 MILES - 25 STREETS)

1961-62 PLANNED IMPROVEMENTS - 26 MILES

 REMACADAMIZING "AREAS" (20 MI. - 200 STREETS)

 STREETS TO BE REBUILT (6 MI. - 12 STREETS)

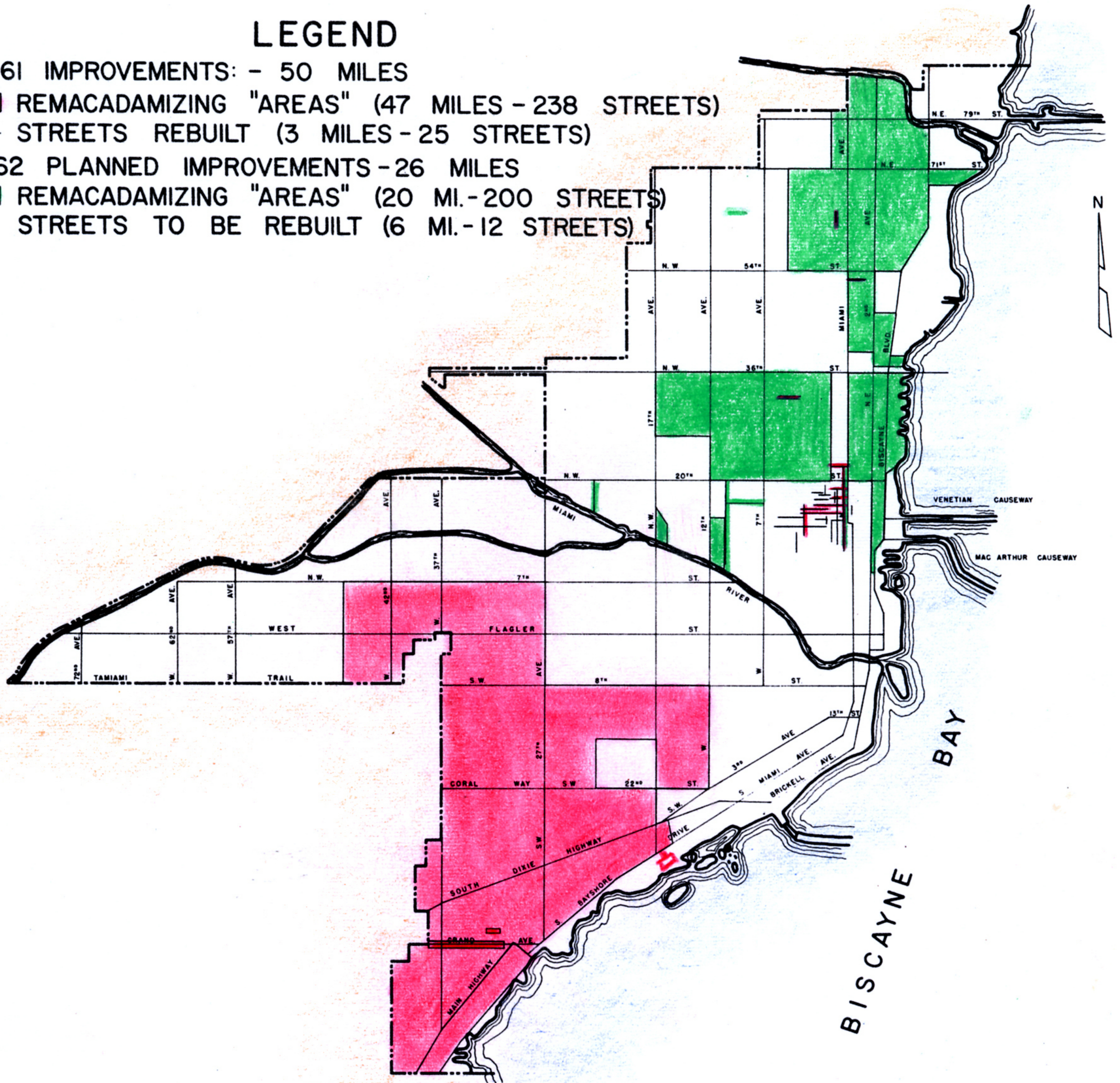

**1961-62 PROPOSED
IMPROVEMENTS**

\$861,000*

* DOES NOT INCLUDE THE BISCAYNE BOULEVARD PLAZA

RECREATIONAL FACILITIES

1960-61 Improvements

Between July 1, 1960, and September 30, 1961, contracts were let for about thirty recreational facility projects. The total price of these projects was \$680,000. About two-thirds of this was for the two big items; the first nine holes of the LeJeune Golf Course with appurtenant structures, and the Plaza Park Swimming Pool. A summary of these projects follows.

LeJeune Golf Course - first nine holes and appurtenant structures	\$332,000
Plaza Park Swimming Pool	133,000
Dinner Key Channel Dredging	25,900
Repair of Hurricane Damage to Marinas	26,100
Comfort Station and Electrical Alterations at Miami Springs Golf Course	18,700
Japanese Tea Garden at Watson Island	17,000
Shuffleboard Courts, Baseball Diamonds, Basketball Courts, etc., at seven parks	38,000
Improved lighting at two parks	15,400
Boys' Fishing Pier at Dinner Key	6,700
Pipe Gallery at Curtis Park Pool	13,900
Comfort Station, Launching Ramp, and Bulkheading at Watson Island	23,300
Miscellaneous Marina & Yacht Dock Improvements	9,400
Bleachers, Fences, and Improved Roads at 3 Parks	20,800

1961-62 Proposed Improvements

Proposed recreational facility improvements scheduled for 1961-62 total \$515,000. The three big items are the construction of the second nine holes at the LeJeune Golf Course, bulkhead improvements at Dinner Key, and Plaza Park development. The latter consists of acquisition of additional land and construction of a community house and other facilities. The proposed 1961-62 improvements are as follows.

Second nine holes at LeJeune Golf Course, plus comfort station and shelter	\$285,000
Plaza Park Development	71,000
Dinner Key Bulkheading	65,000
Other Dinner Key improvements including paving, showers and mooring buoys	20,000
Community Building at Coral Gate Park	27,500
Improved Lighting at Shenandoah, Grapeland and Curtis Parks	22,000
Fern Isle Nursery Greenhouse and storage building	15,800
Launching Ramp at Morningside Park	8,000

RECREATIONAL FACILITIES

1960-61 IMPROVEMENTS \$ **680,000**

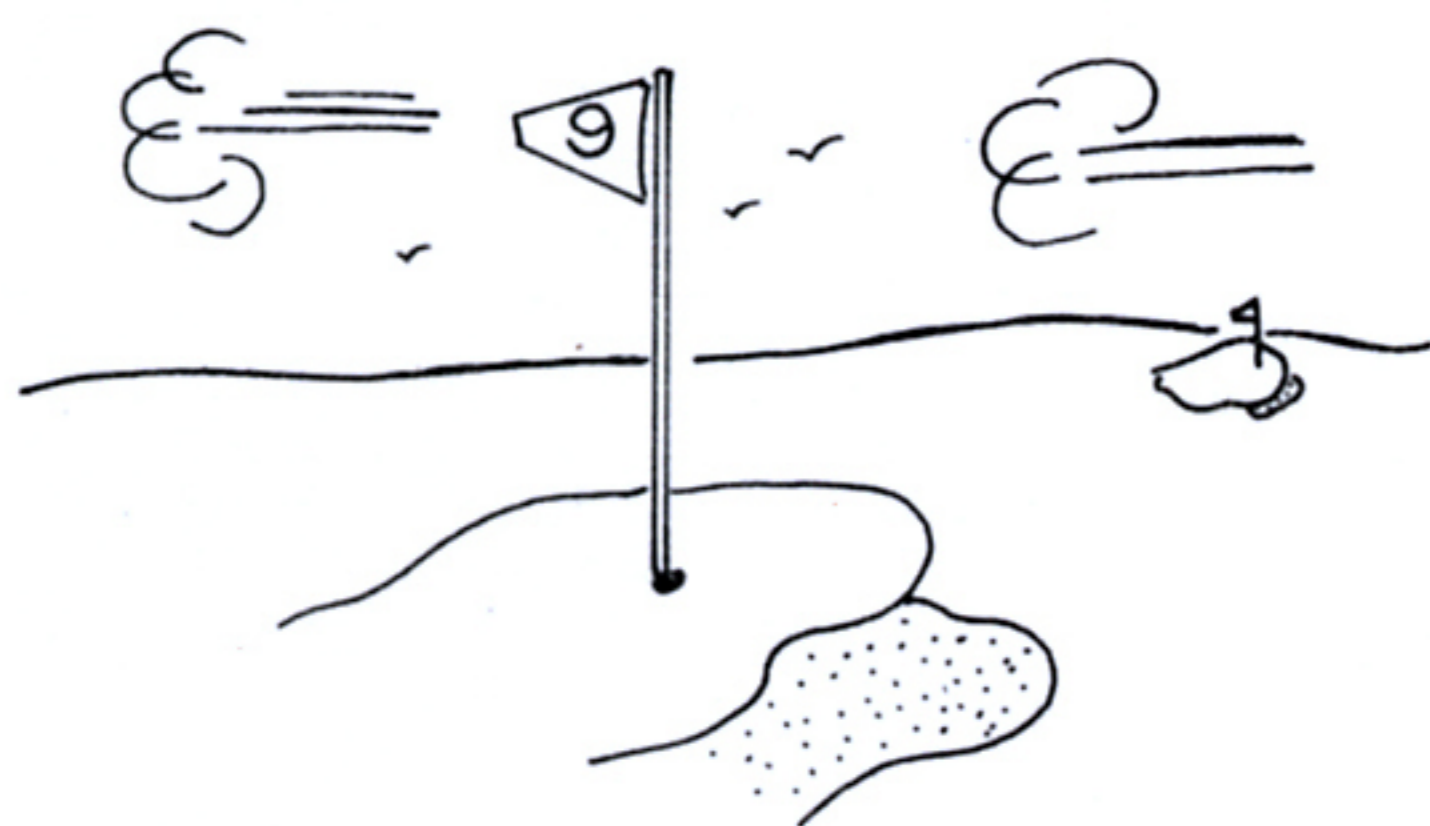

LE JEUNE GOLF COURSE
FIRST 9 HOLES

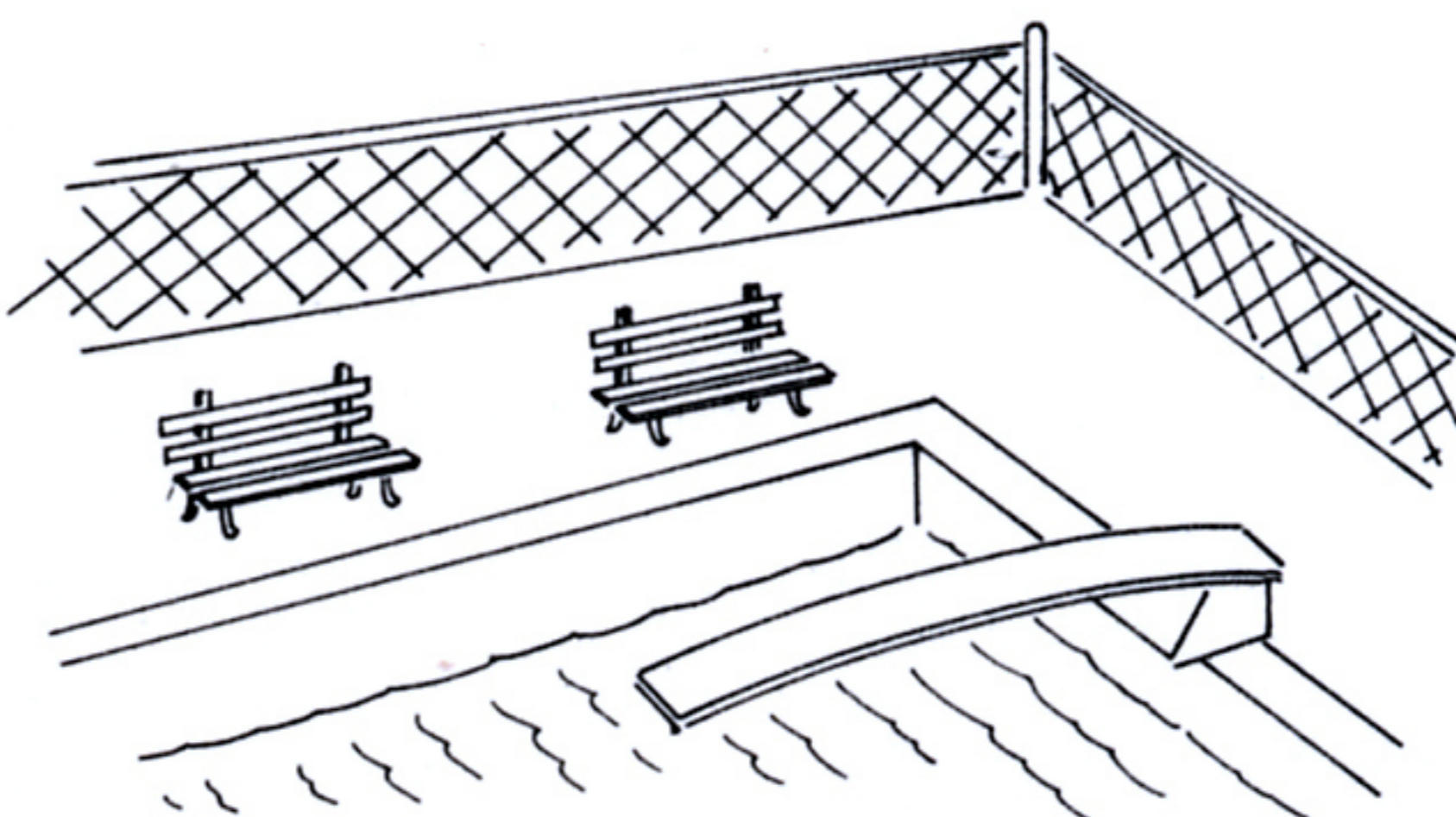

PLAZA PARK POOL

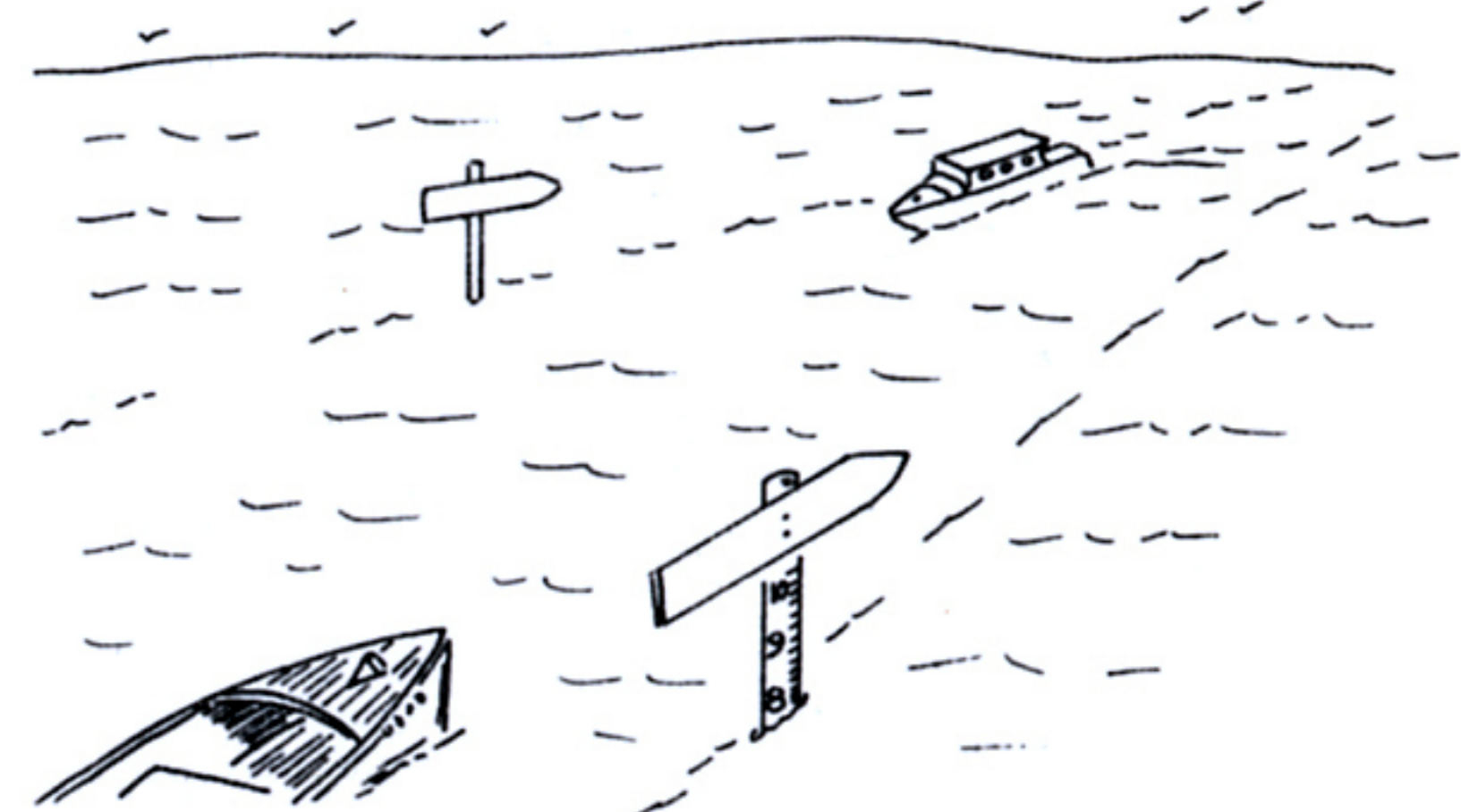

DINNER KEY
CHANNEL DREDGING

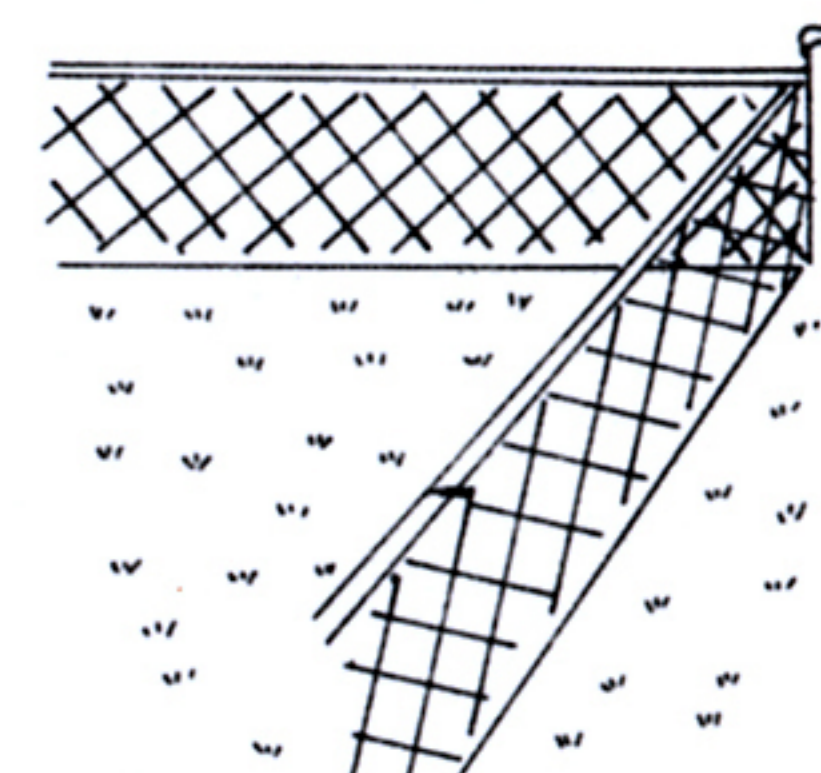
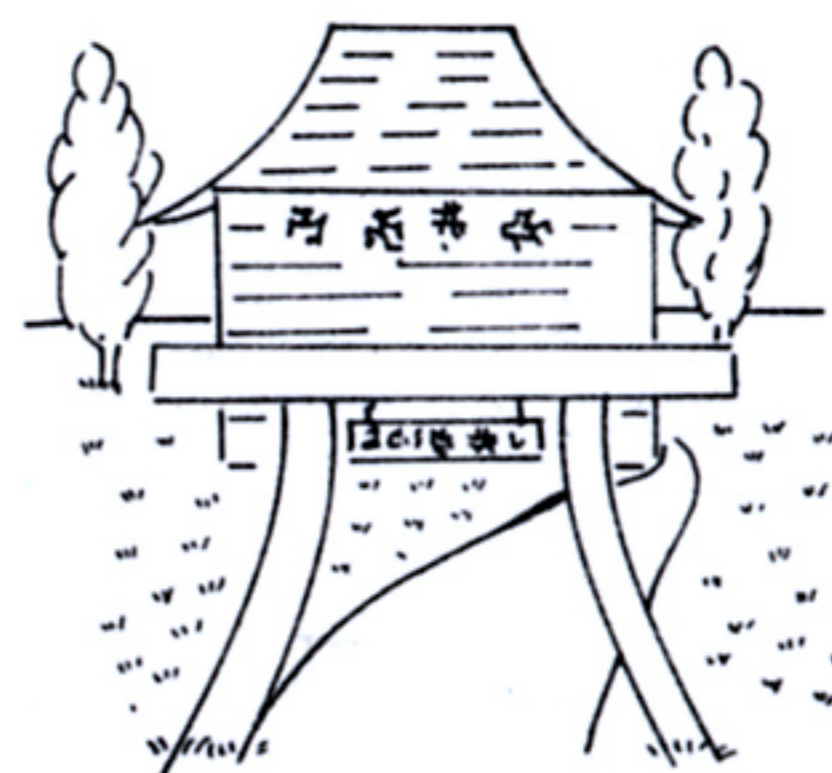
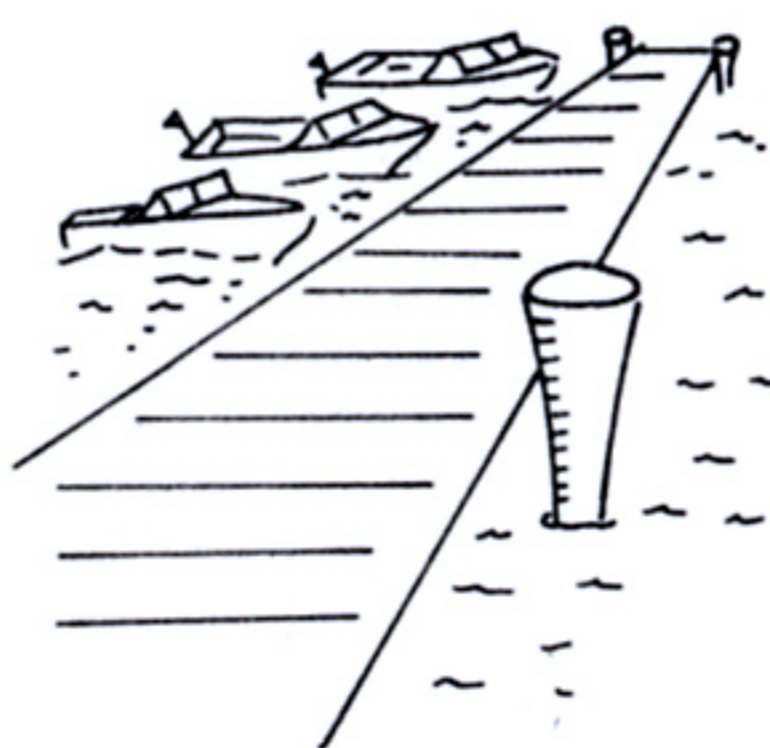
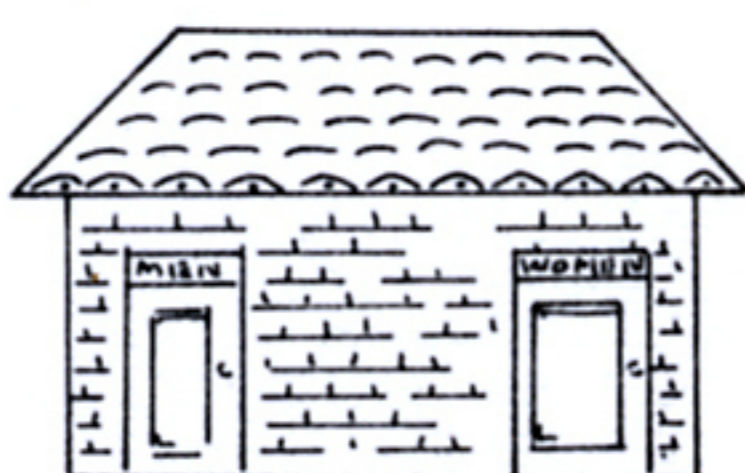
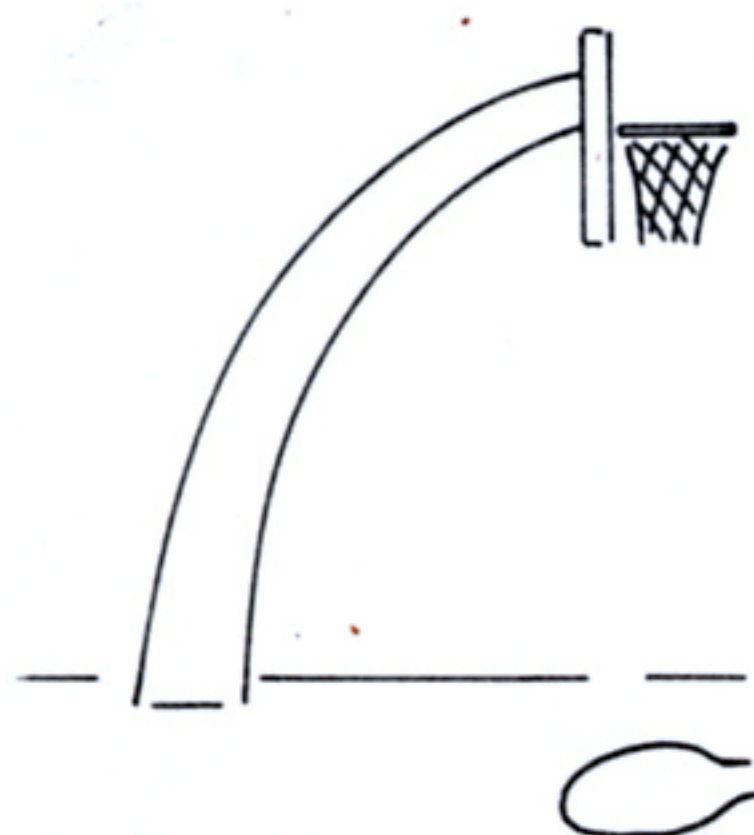

MISCELLANEOUS IMPROVEMENTS TO 12 PARKS & MARINA FACILITIES

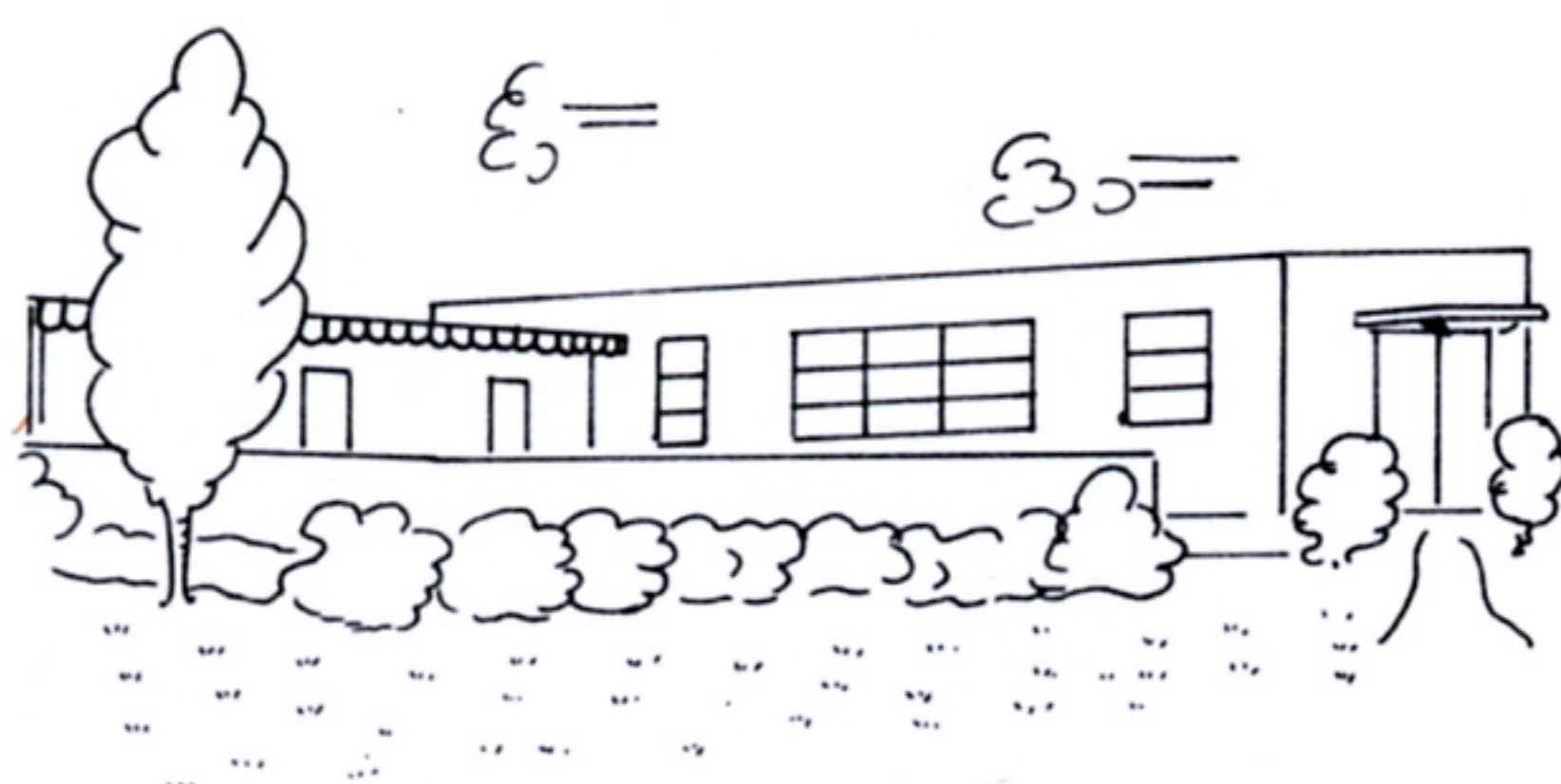

COMMUNITY BLDG.
CORAL GATE PARK

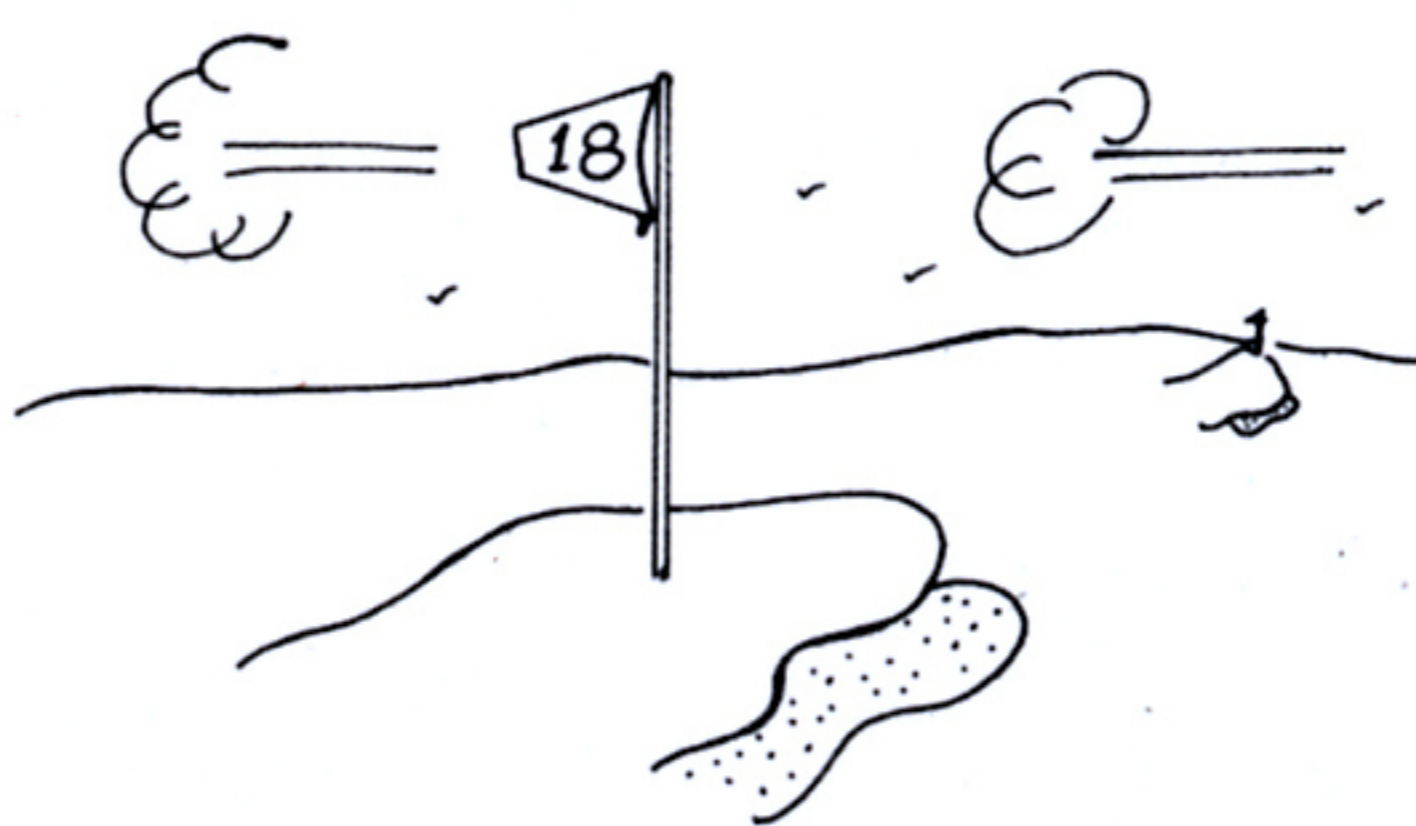

LE JEUNE GOLF COURSE
SECOND 9 HOLES

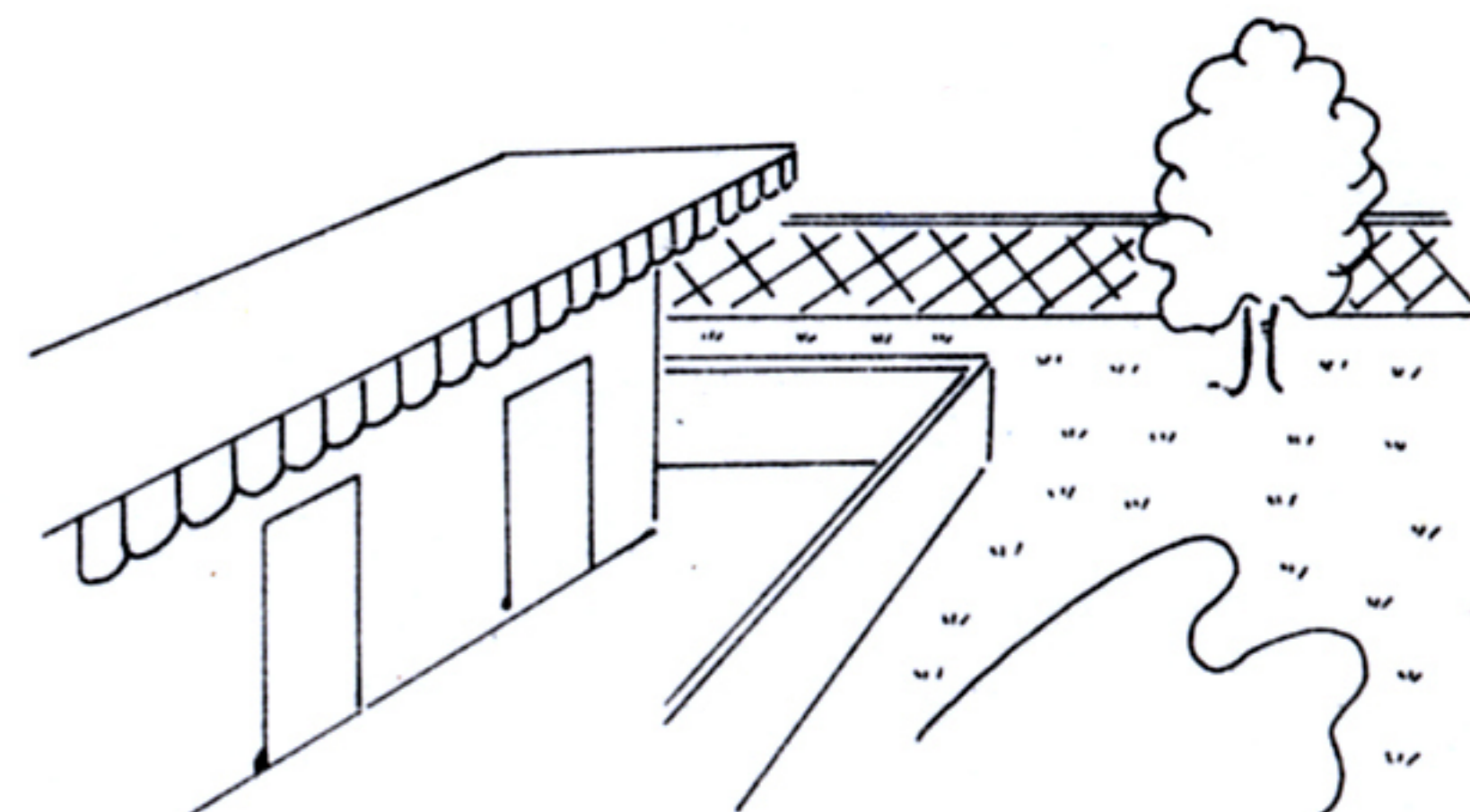

DEVELOPMENT OF
PLAZA PARK

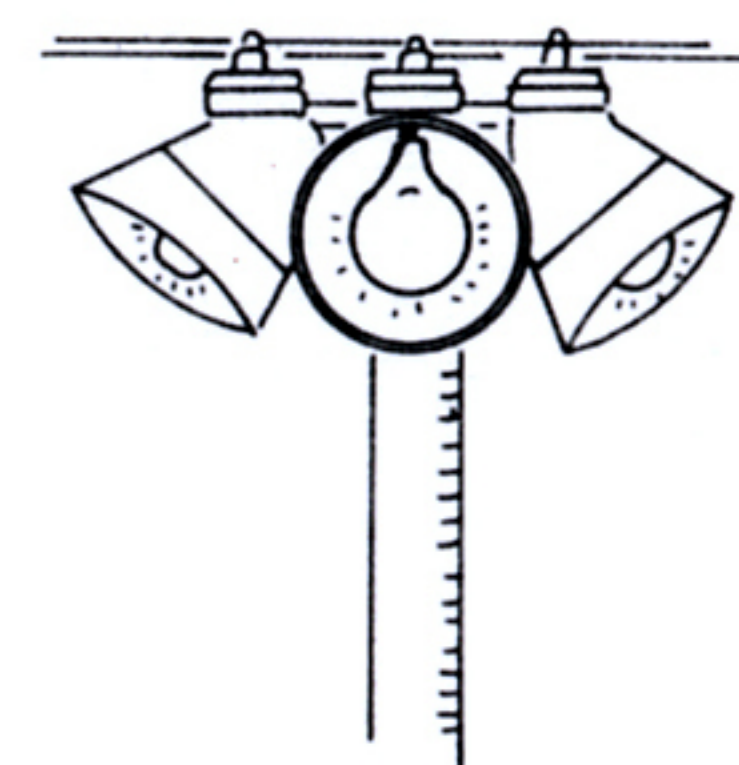
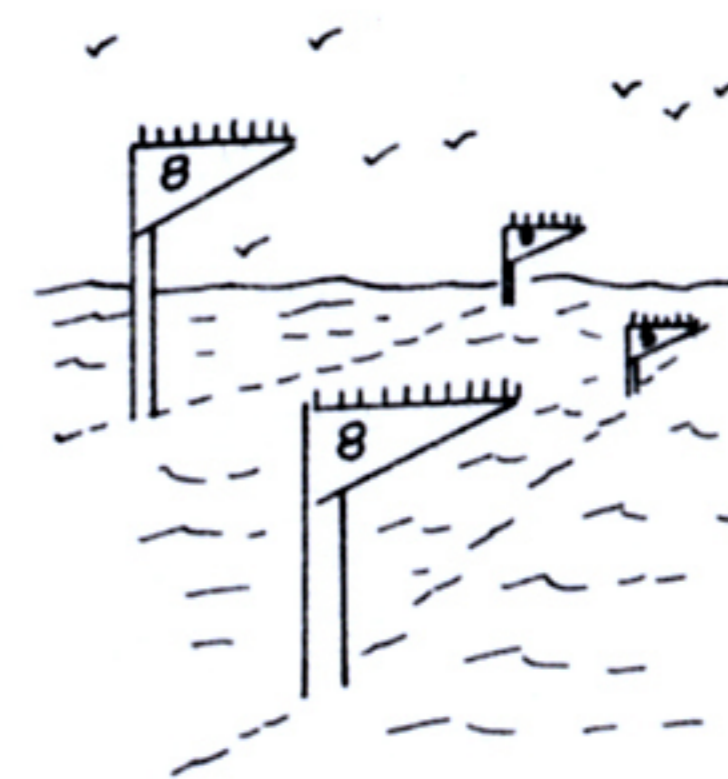
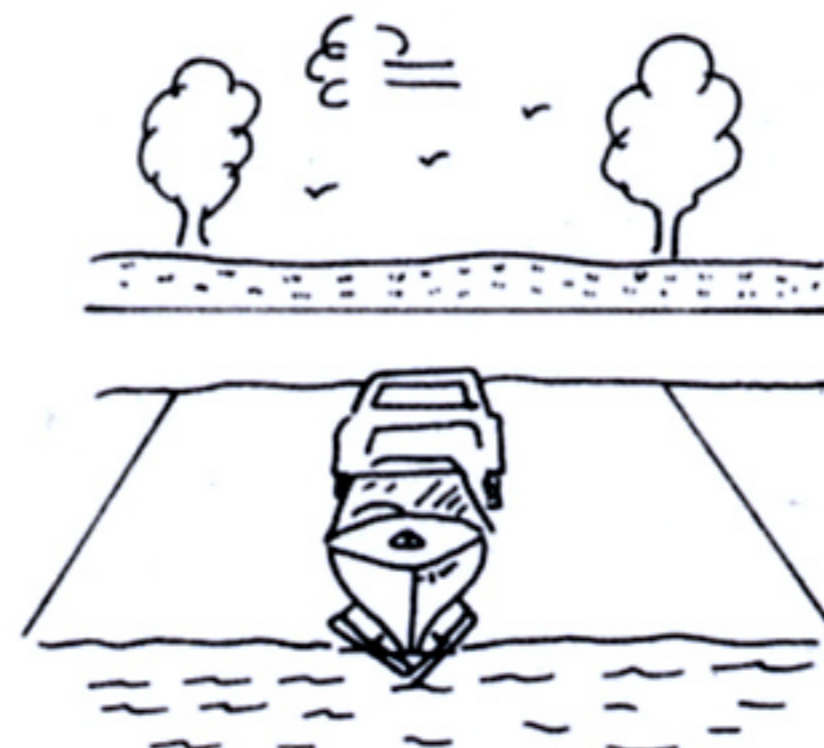
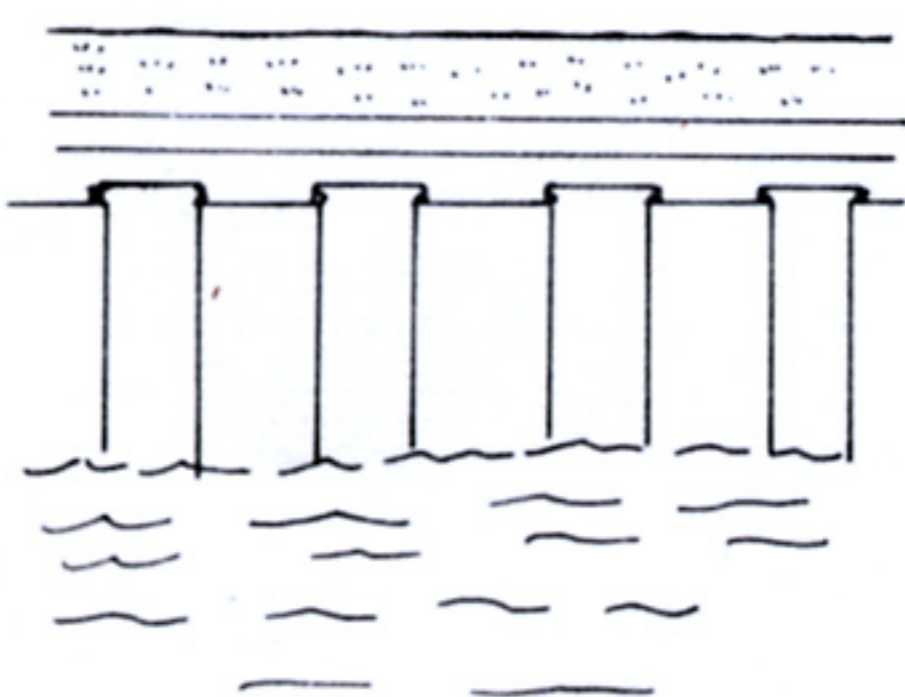

MISCELLANEOUS IMPROVEMENTS TO 6 PARKS & MARINA FACILITIES

1961-62 PROPOSED IMPROVEMENTS \$ **515,000**

STRUCTURAL IMPROVEMENTS

1960-61 Improvements

Between July 1, 1960, and September 30, 1961, contracts were let for several structural improvements to City facilities and for the construction of new facilities. The total cost of these improvements was \$672,000, with the new Central Fire Station accounting for the bulk of this. These improvements are as follows:

Central Fire Station	\$500,000
Repainting Miami Stadium	53,300
Shenandoah Library Addition	24,000
Site for Lemon City Library	35,000
Torch of Friendship	18,000
Apparatus Room at Fire College	6,000
Miscellaneous Structural Improvements to Orange Bowl, Miami Stadium, Watson Building, etc.	35,700

1961-62 Proposed Improvements

Scheduled for 1961-62 are \$440,000 in structural improvements. Notable among these are: a new Lemon City Branch Library, a body and fender shop at the Motor Pool, and a new Fire Division maintenance shop. A brief listing of these improvements follows.

Lemon City Library	\$102,000
Fire Division Maintenance Shop	130,000
Motor Pool Body and Fender Shop	88,000
New Roof for Dinner Key Auditorium	56,000
Fire Division Improvements (2 reserve apparatus rooms)	30,000
Orange Bowl Improvements	27,000
Communication Division Improvements	7,000

STRUCTURAL IMPROVEMENTS

1960-61 IMPROVEMENTS \$ 672,000

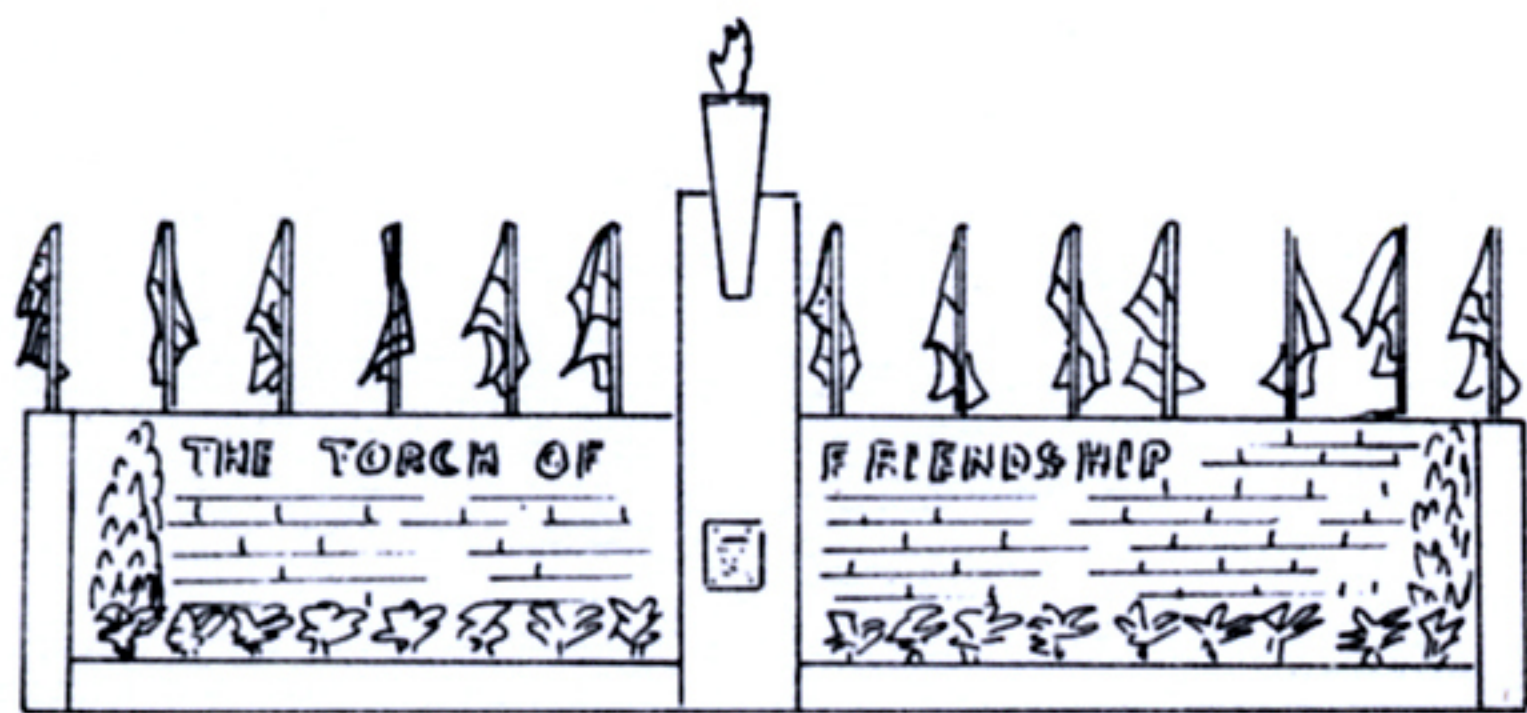

TORCH OF FRIENDSHIP

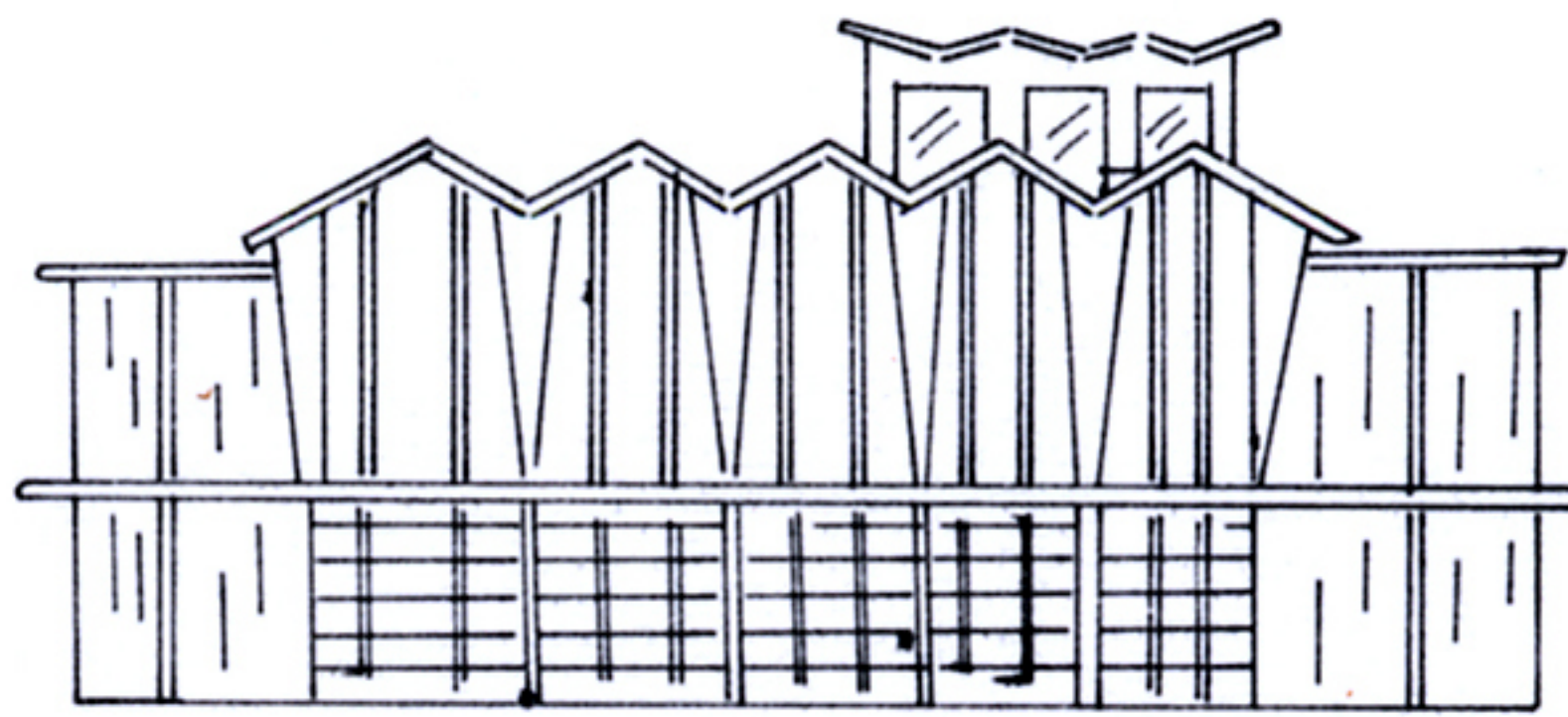

CENTRAL FIRE STATION

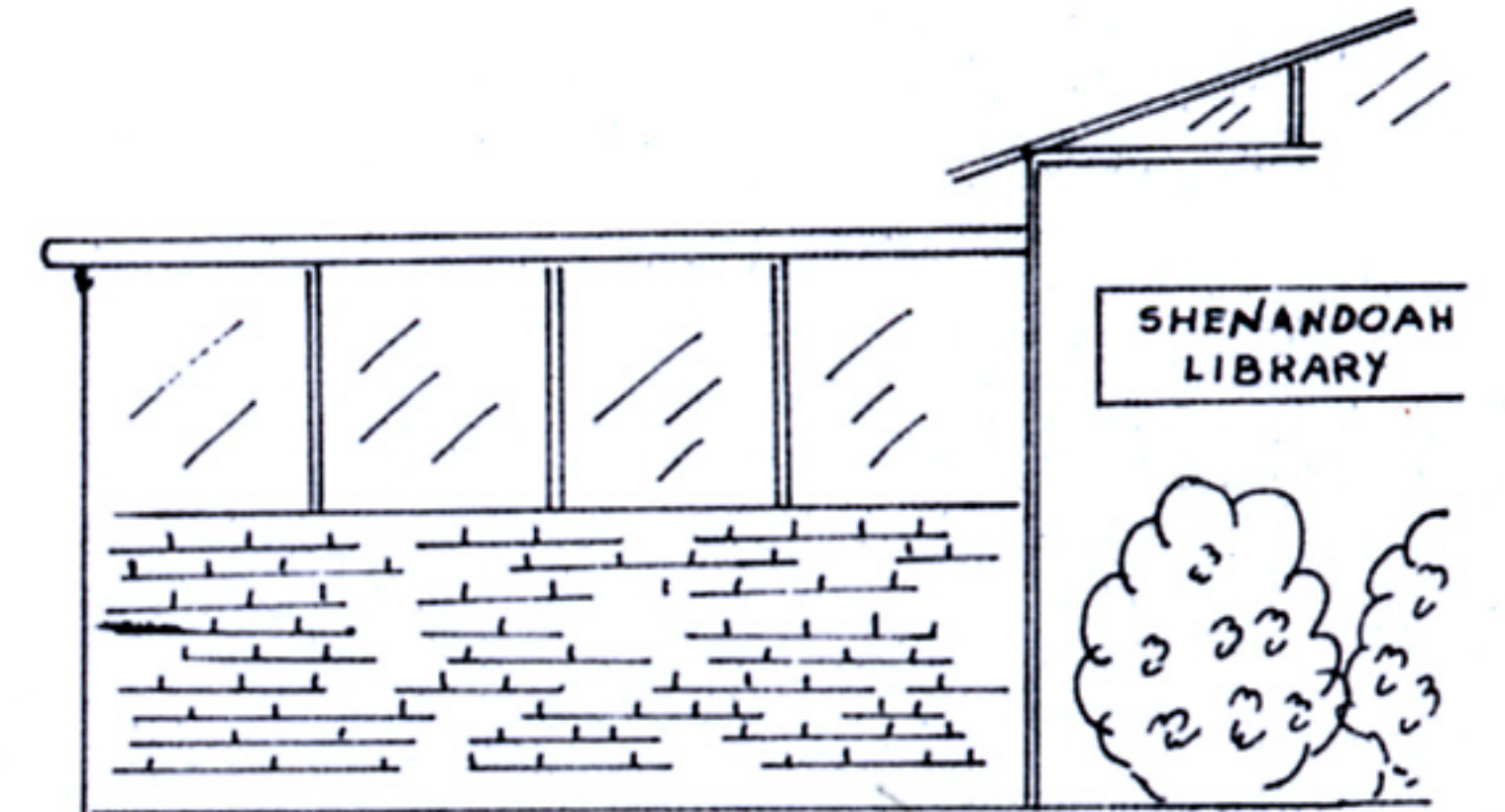

SHENANDOAH LIBRARY ADDN.

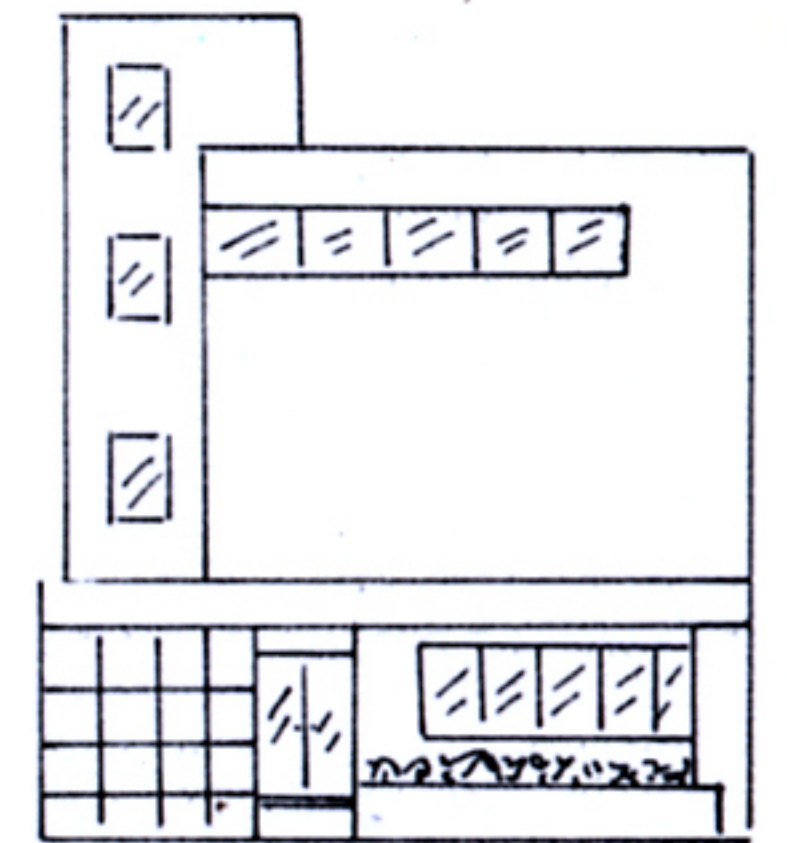
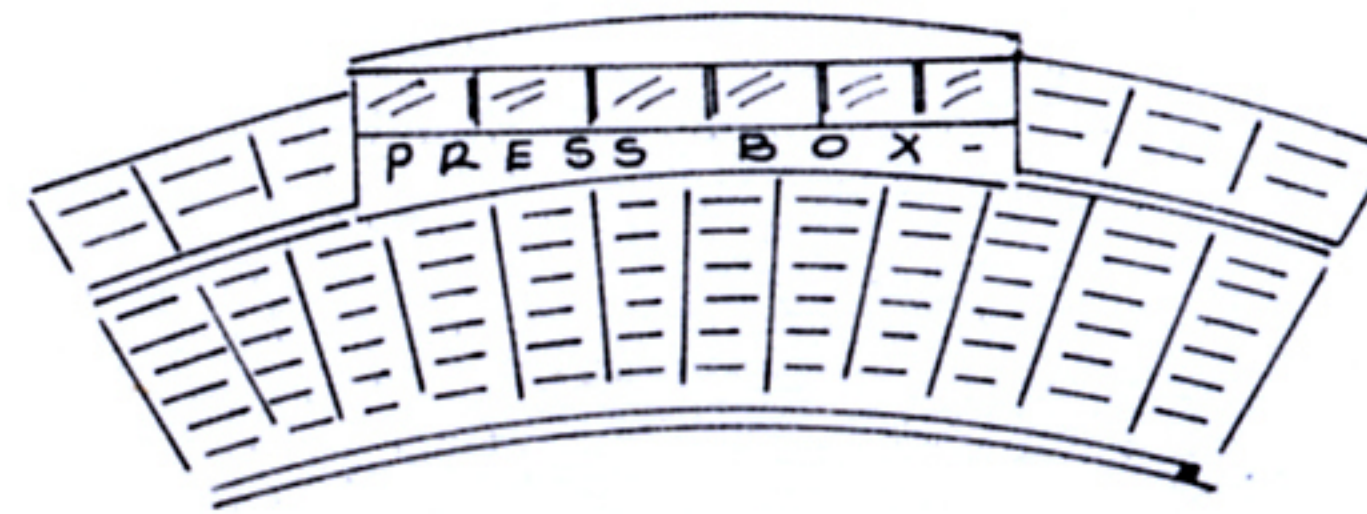
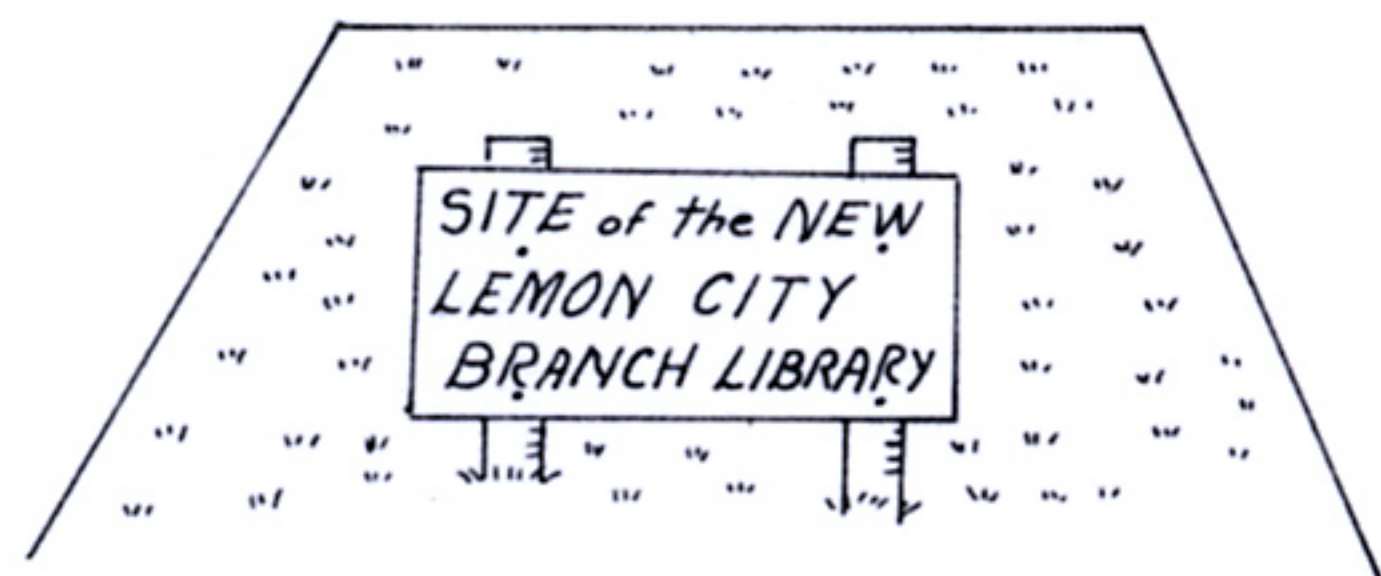
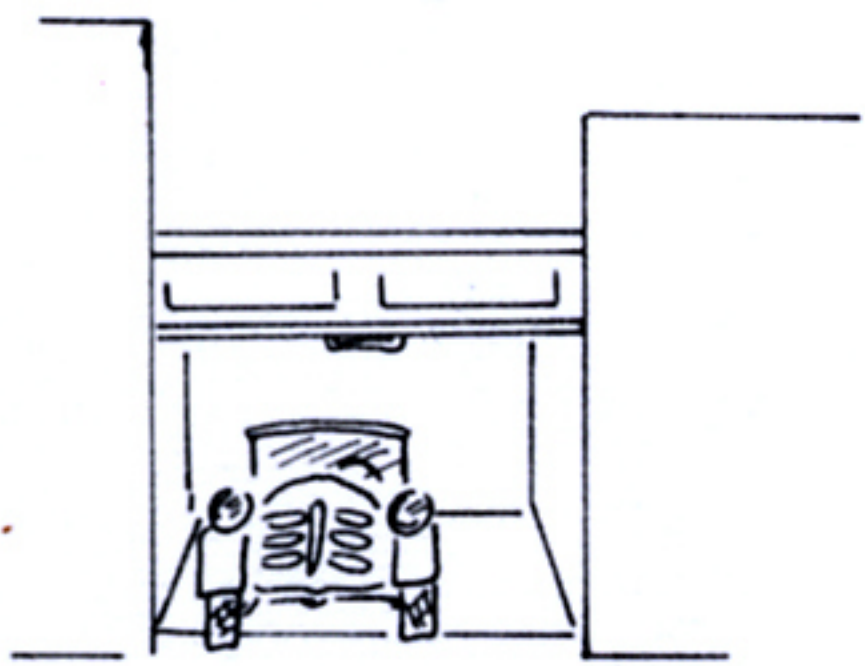

MISCELLANEOUS IMPROVEMENTS TO CITY BUILDINGS

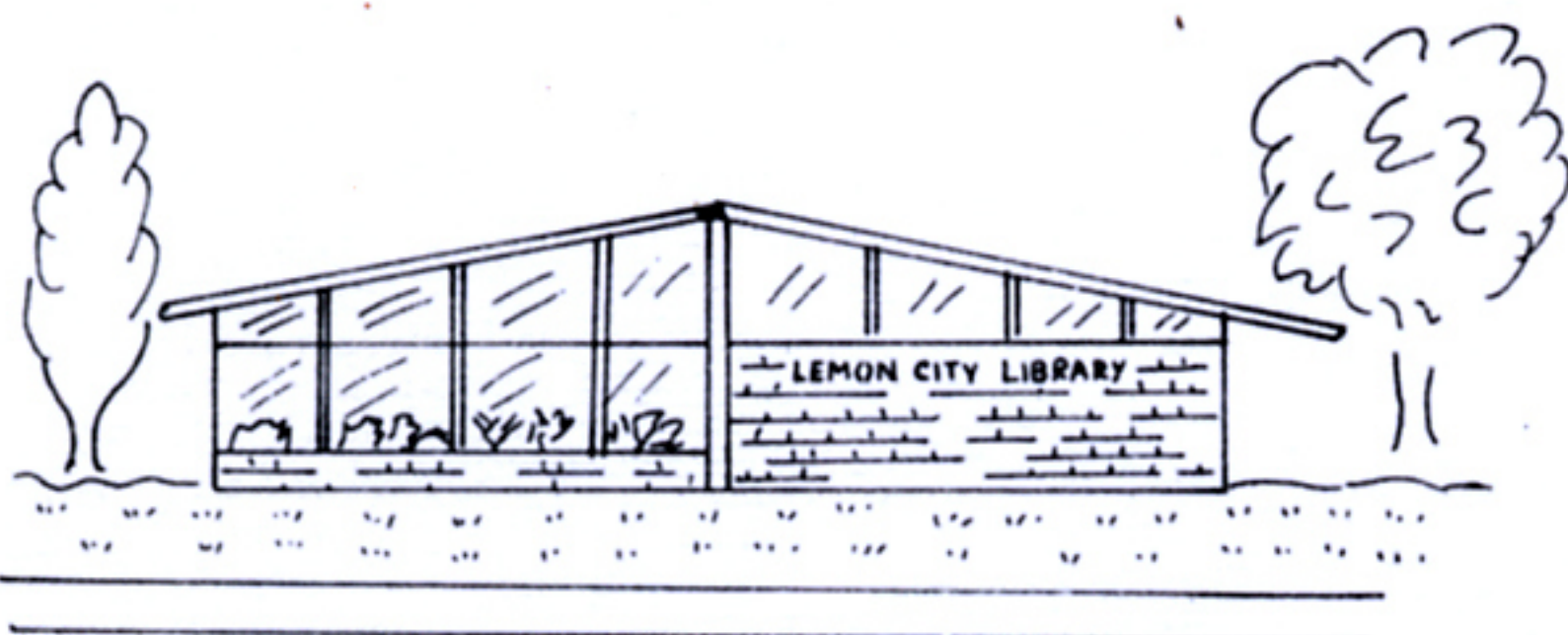

LEMON CITY LIBRARY

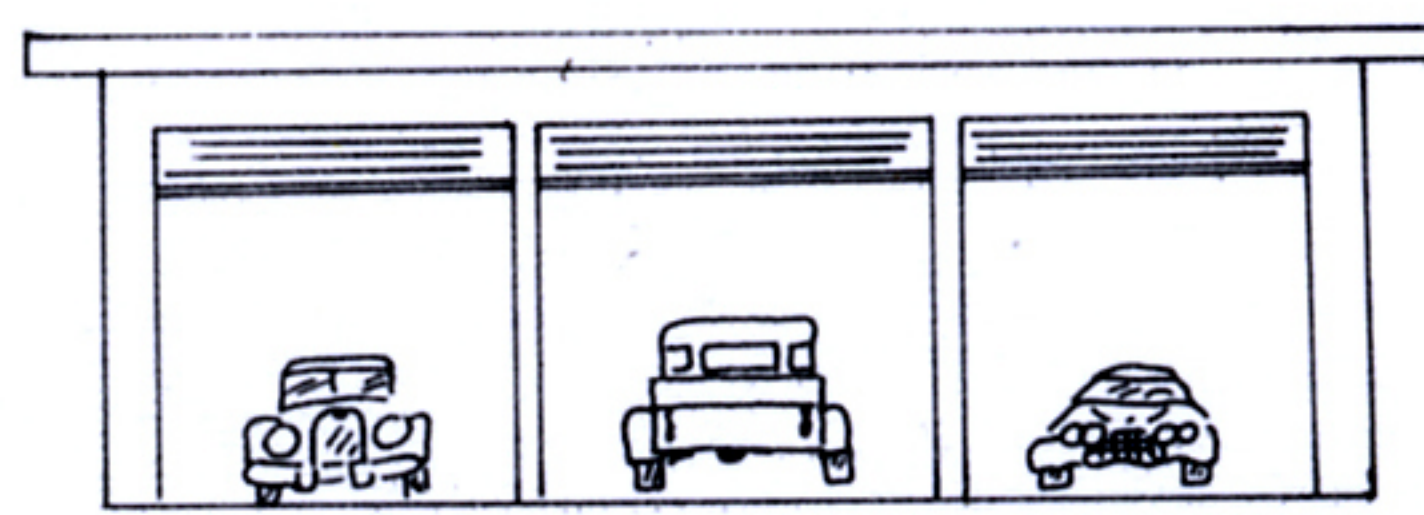

MOTOR POOL BODY AND FENDER SHOP

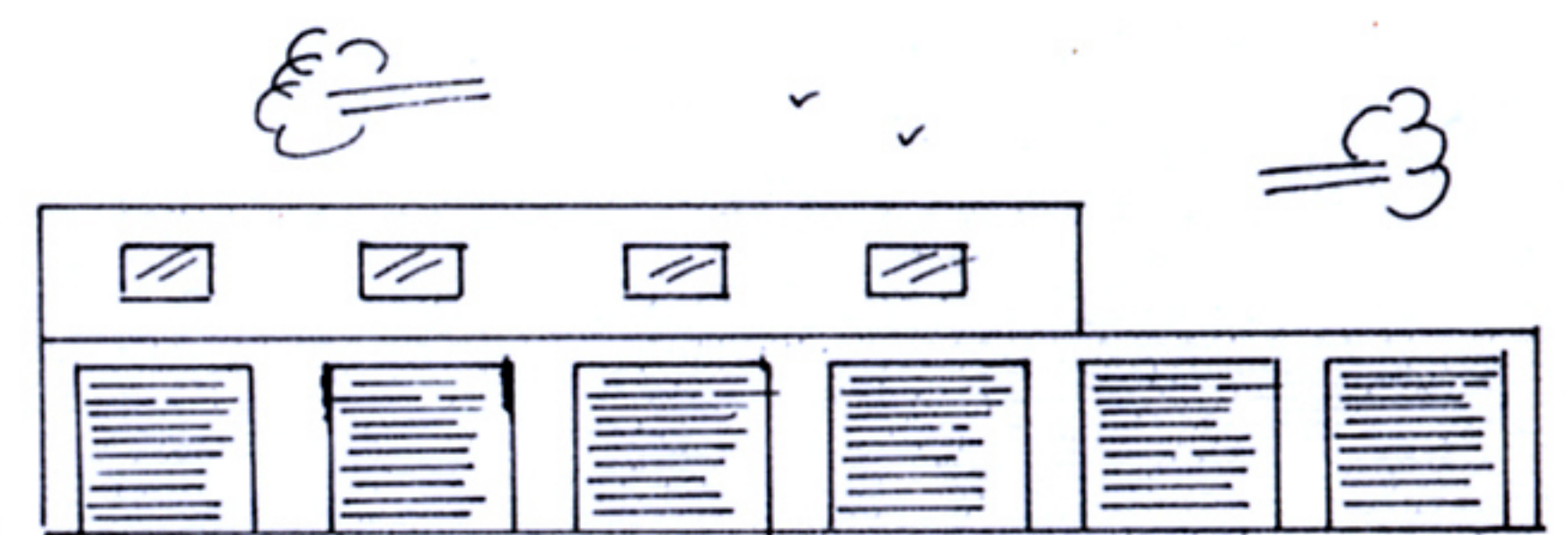

FIRE MAINTENANCE BUILDING

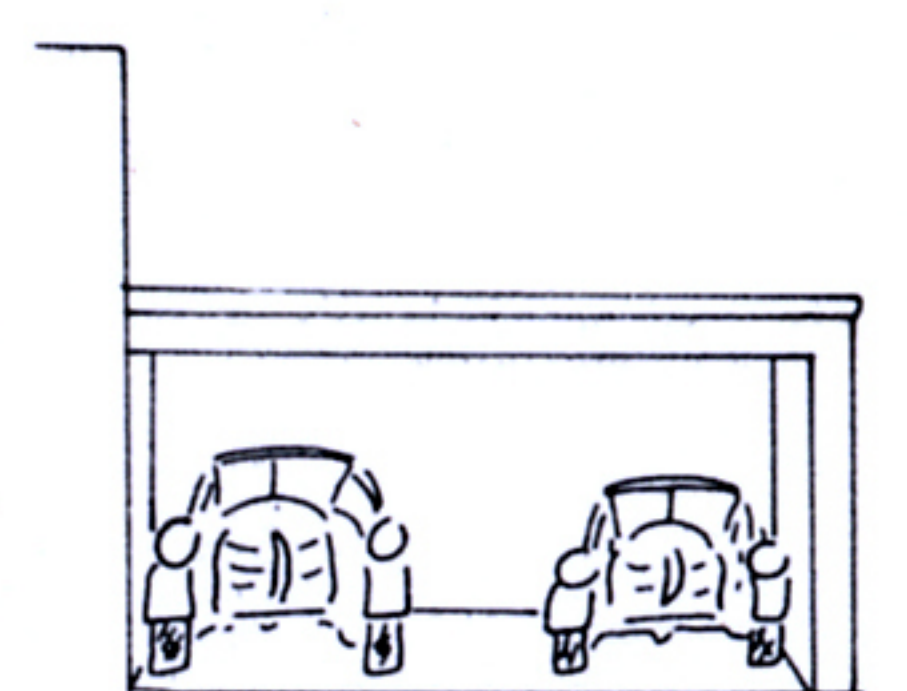
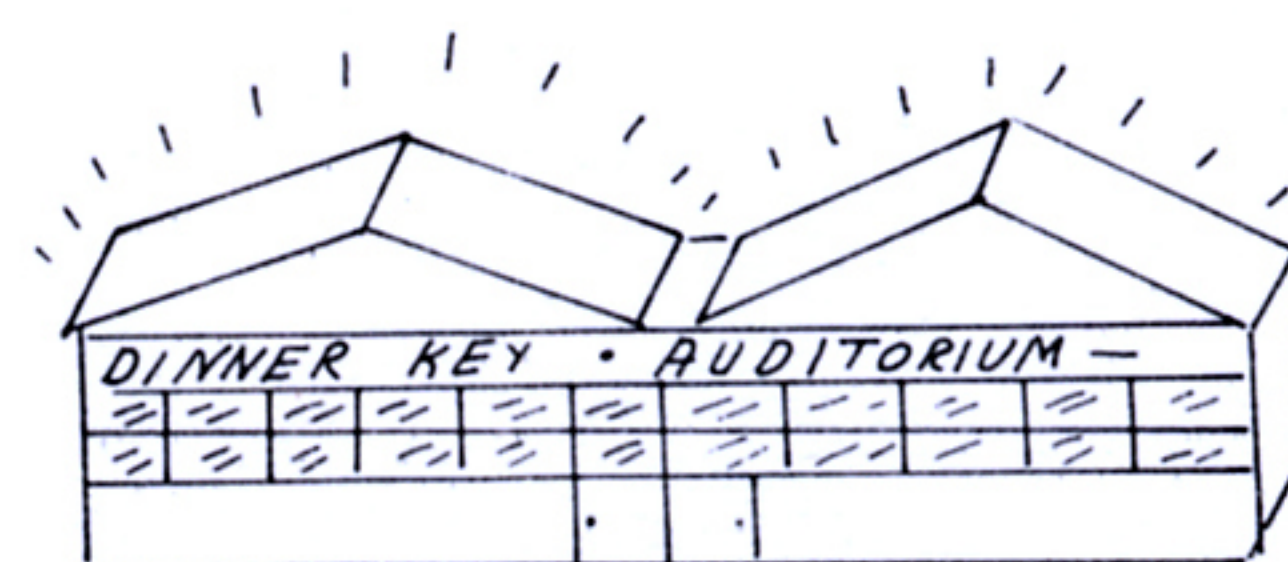
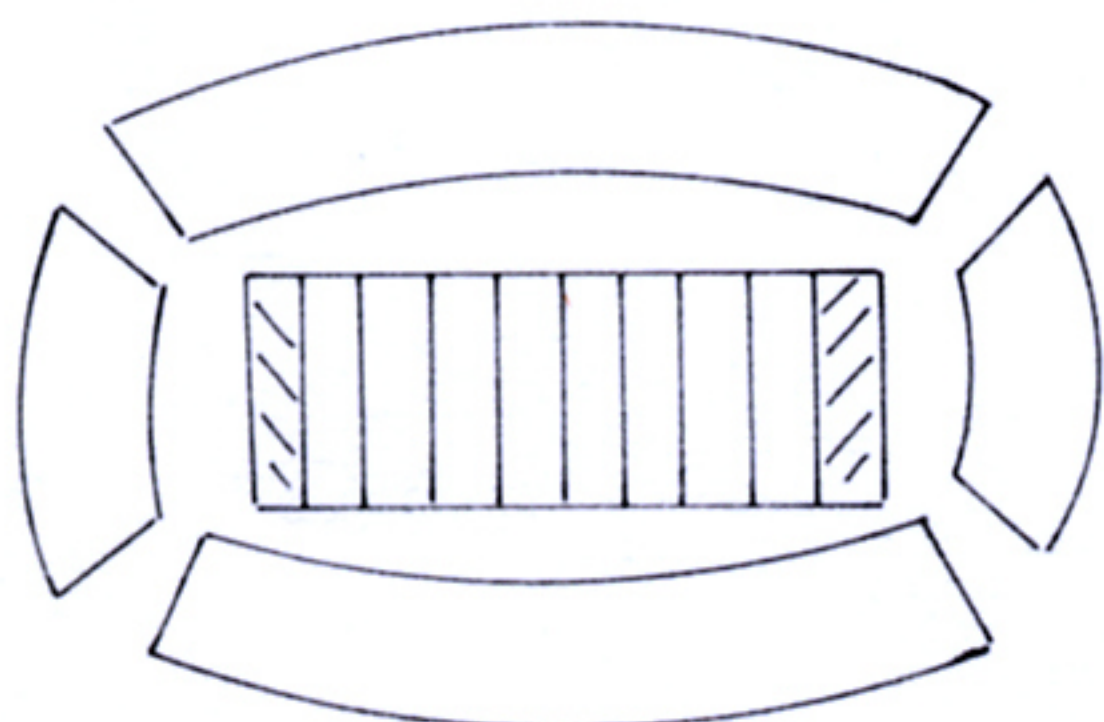

MISCELLANEOUS IMPROVEMENTS TO CITY BUILDINGS

1961-62 PROPOSED IMPROVEMENTS \$ 440,000

CITY BEAUTIFICATION

1960-61 Improvements

Between July 1, 1960, and September 30, 1961, the City landscaped the following highway areas at a cost of \$33,000.

Dixie Highway from Brooker Street to S. W. 27 Avenue
Biscayne Boulevard from N. E. 13 Street to NE 23 Street
S. W. 3 Avenue from SW 15 Road to SW 22 Street
DuPont Plaza Area - four small beautification projects

1961-62 Proposed Improvements

One major beautification project, the Biscayne Boulevard Plaza, is proposed for the 1961-62 fiscal year. This project, costing \$550,000, will consist of the redevelopment and beautification of Biscayne Boulevard from S. E. 2nd Street to N. E. 5th Street. Traffic islands will be relocated and special service lanes provided. These islands as well as sidewalk areas will be landscaped with tropical plantings, fountains, and pools. Sidewalks will be widened and constructed of colorful terrazzo. Consideration is also being given to the incorporation of sidewalk cafes.

CITY BEAUTIFICATION

1960-61
IMPROVEMENTS

\$33,000



LANDSCAPING OF DIXIE HWY, BISCAYNE BLVD., S.W. 3RD AVE., & DUPONT PLAZA

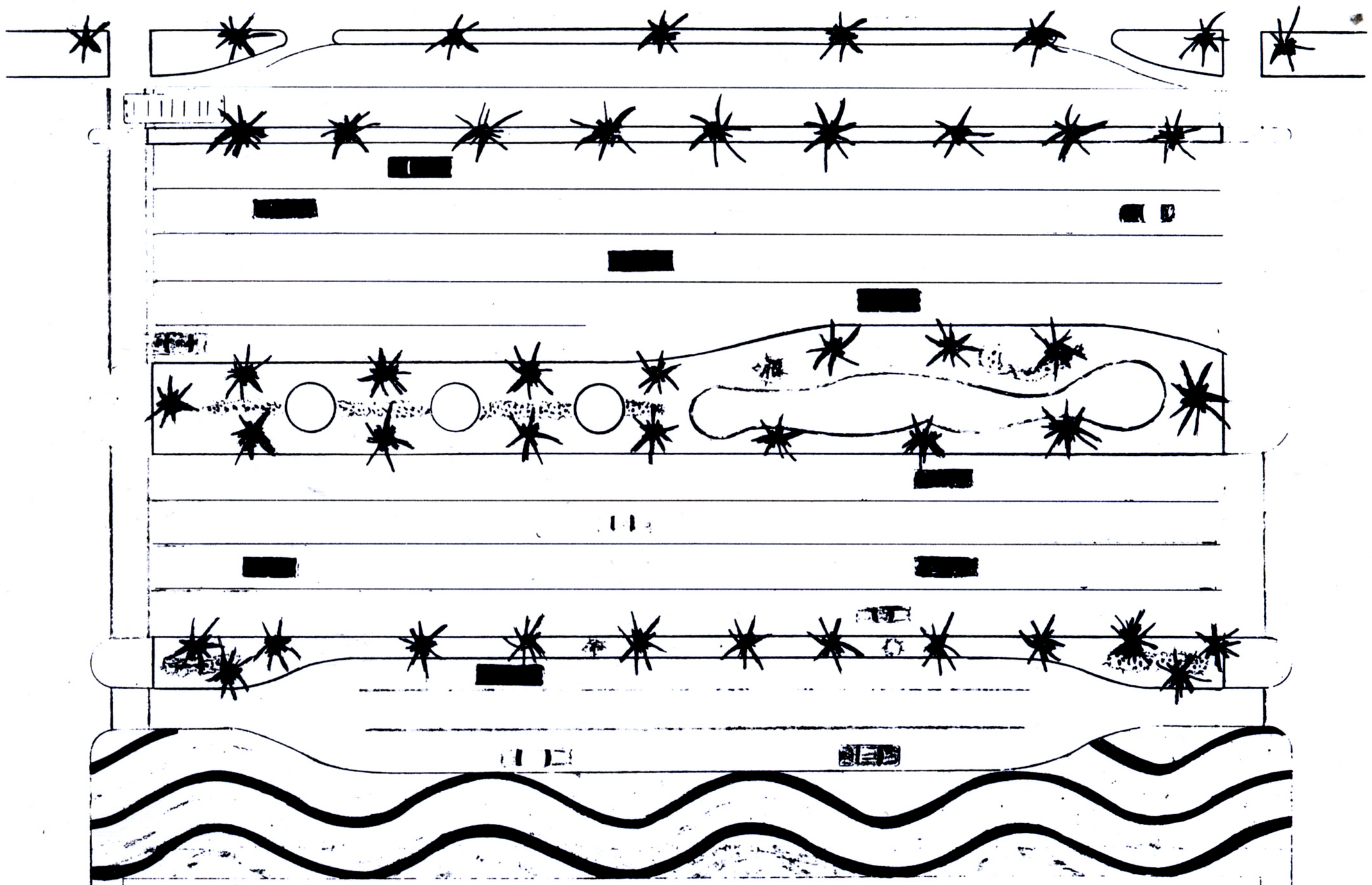

BISCAYNE BOULEVARD PLAZA DEVELOPMENT

1961-62 PROPOSED
IMPROVEMENTS

\$550,000

STREET LIGHTING

1960-61 Improvements

Between July 1, 1960, and September 30, 1961, the City of Miami increased its street lighting by better than 10%. There was a net gain of 590 luminaires installed (or in the process of being installed), increasing the total output of Miami's street lighting system by 12,400,000 lumens. These improvements represent an annual increase of \$89,000 in the City's street lighting budget. Major projects include: Biscayne Boulevard (from S.E. 2nd Street to N.E. 5th Street), S.W. 1st Street, S.W. 8th Street, the Central Business District, the Central Negro Area, and Coconut Grove.

1961-62 Proposed Improvements

During the 1961-62 fiscal year, street lighting will be further improved to the extent of an additional \$55,000 annual increase in the street lighting budget. This will be for such lighting projects as:

Modernization of Lighting on Residential Streets	\$20,000
Modernization in Connection with State Road Projects	11,000
Modernization in Connection with City Highway Development	6,000
Individual Lighting Improvements at Requested Locations	13,000
Test Lighting Program	5,000

STREET LIGHTING

1960-61
IMPROVEMENTS

\$89,000
(ANNUAL INCREASE)

LEGEND

1960 - 61 IMPROVEMENTS

GENERAL AREAS OF IMPROVED LIGHTING (3 sq.miles)

STREETS WITH IMPROVED LIGHTING (24 miles)

1961 - 62 IMPROVEMENTS

GENERAL AREAS OF IMPROVED LIGHTING (6 sq.miles)

STREETS WITH IMPROVED LIGHTING (8 miles)

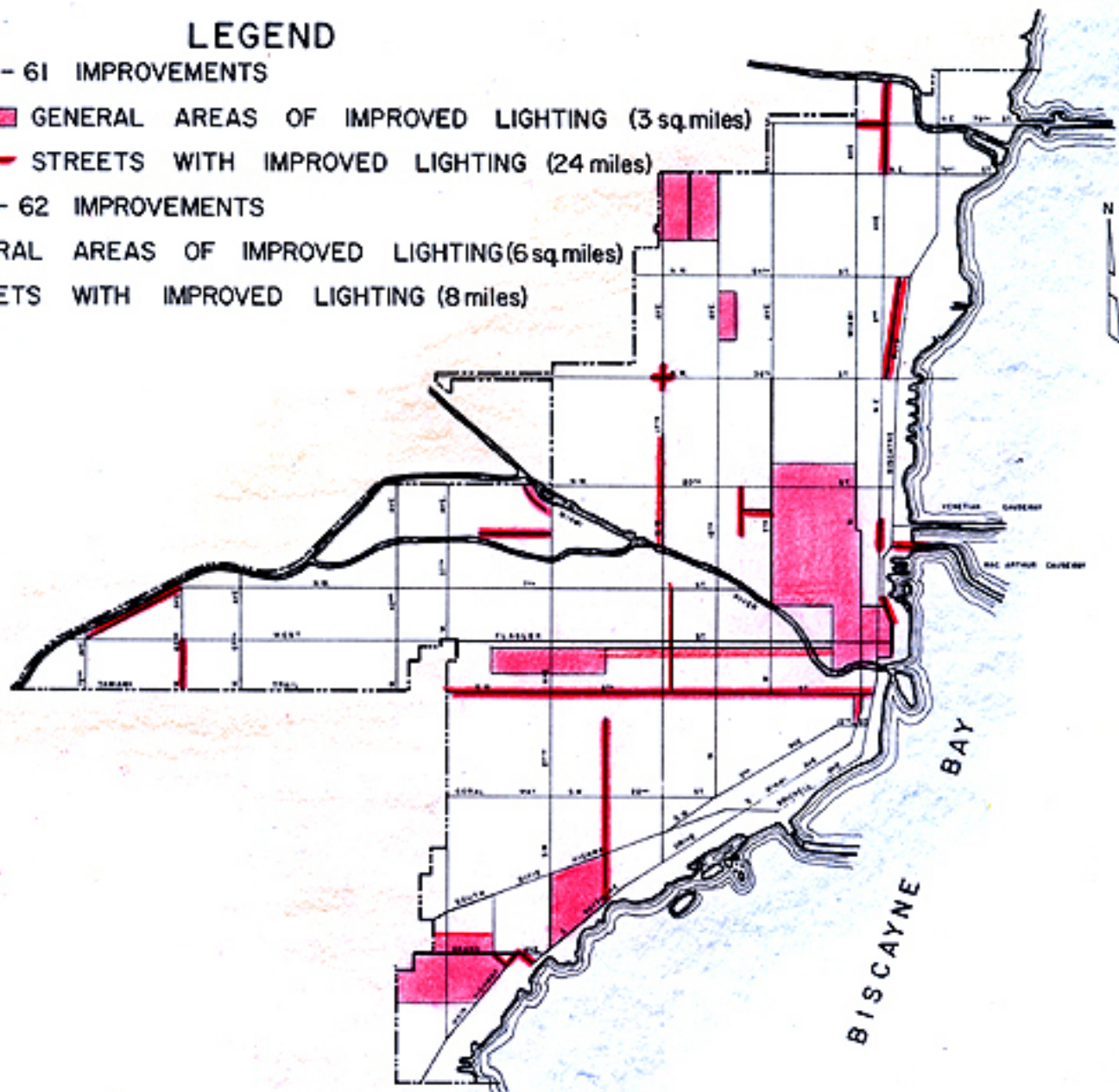

1961-62 PROPOSED
IMPROVEMENTS

\$55,000
(ANNUAL INCREASE)

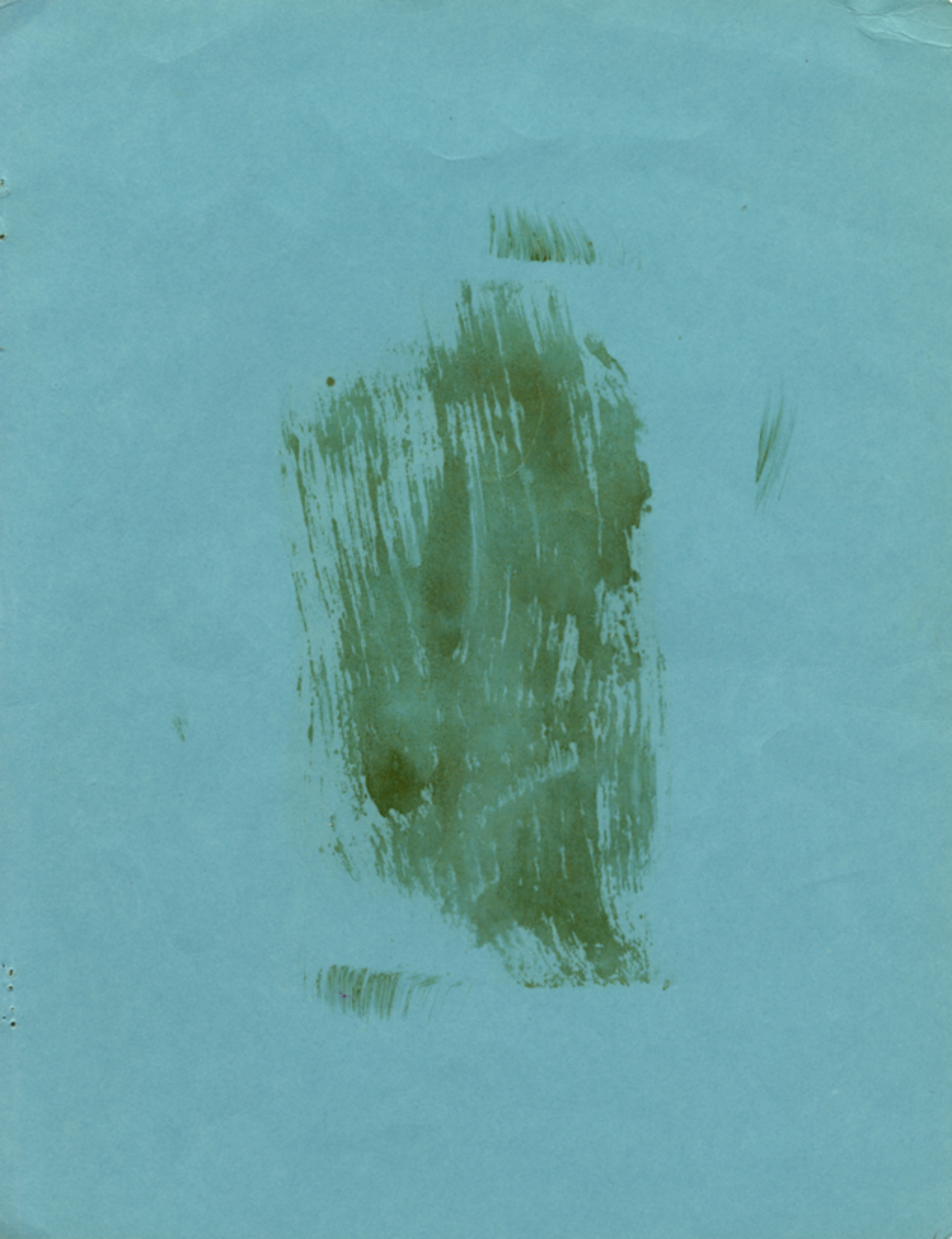

The CITY PLANNING BOARD
of MIAMI, FLORIDA